

SECURITY

SYSTEM

INSTALLATION

MANUAL

SX-V



The Interactive Technologies, Inc.

SX-V SECURITY SYSTEM

REFERENCE and

INSTALLATION Manual

**Interactive Technologies, Inc.
2266 North Second Street
North St. Paul, MN 55109**

(612) 777-2690

(800) 777-1415

Technical Services (800) 777-2624

This manual is for the Interactive Technologies, Inc. SX-V Security System. Do not use this manual if you are installing or working on any other ITI alarm panels. This Reference and Installation Manual is specific to the features and functions of the ITI SX-V System Software, Dated 9-1-89. Subsequent software revisions may have changed some operational specifications. Please refer to the Reference and Installation Manual specific to the software version and date of your system.

©ITI 1989,1990,1991

PART # 46-074-F
Issue Date 5/05/93

Table of Contents

Introduction	1	Changing Exit Delay Time	88
SX-V Features Summary	2	CPU Account Number by TouchPad	88
Siren Sounds	3	Central Station Phone Numbers	88
Protection Levels	4	CPU Real Time Clock	89
Sensor Numbering	4	Setting Temporary Access Code	89
Pre-Programmed Sensor Numbers	5	Optional Sensor Numbers	90
Optional Sensor Numbers	7	Optional Feature Numbers	94
Optional Feature Numbers	8	Adding	98
Sensor Number Chart	8	Connecting CPU to Central Stations	99
SX-V CPU	10	Preliminary Steps	99
U.L. Systems	10	Central Station Connections	99
Specifications	11	Central Station Receiver Programming	100
CPU Installation	14	Buddy Transmitter Module	104
CPU Hardware Tamper Input	17	Testing	106
TouchPads	19	Checklist	106
Hi Tech Hardware Touchpad & Display	19	Protection Level/Status Test	107
Wall Mount Wireless TouchPad 60-100	35	Temporary Access Code Test	107
Hi Tech Wireless TouchPad 60-365	39	Sensor Test	108
Hand Held Wireless TouchPad 60-101	41	Duress Code Test	109
Hardwire TouchPad & Display 60-193	42	Standby Power Test	110
Sensors	45	AC Power/Transformer Test	110
Door/Window Sensor 60-135 & 60-151	45	Indirect Bypassing Test	111
Recessed Mount Door Sensor 60-239-11	45	Direct Bypassing Test	112
Sound Sensor (Wireless) 60-249	49	Open Sensor Protest	112
Smoke Sensor 60-106	51	Alarm Memory Test	113
Rate-of-Rise Sensor 60-137	53	Phone Test	114
Fire Pull Station 60-137	56	Central Station Data Card	115
Passive Infrared Motion Sensor 60-104	57	Customer Data Card	120
Shock Sensor 60-185	59	SX-V Installation Record Card	122
Freeze Sensor 60-185	62	SX-V Service Record	123
Portable Panic Transmitters 60-149	65	Protection Provide Card	124
Pendant Panic Sensor 60-329	67	Warranty	125
Sirens	70	Maintenance and Inspections	126
Hardwire Interior Siren & Piezo 60-278	71	Alarm System Limitations	126
Hardwire Interior Siren 60-136	71	Telephone Problems	128
Hardwire Exterior Siren 13-028	72	FCC	128
Phone Jack Siren 60-108	73	APPENDIX A Smoke sensor	130
Wireless Interior Siren 60-194-235	74	APPENDIX B DS924 (PIR)	134
Programming	79	Glossary	138
Programming the SX-V CPU	79		
Sensor Programming	82		
Sensor Type	85		
Programming CPU Options	87		
Changing Access Code	87		
Entering Duress Code	87		
Changing Entry Delay Time	88		

INTRODUCTION

This Installation Manual is designed to give you the information necessary to install and test an Interactive Technologies SX-V Security System.

It is assumed that the technicians reading this manual have thoroughly familiarized themselves with the operation of the system. You cannot be expected to understand how to install the SX-V system unless you already know how to use it.

If you are not yet familiar with how to use the SX-V system then do the following before proceeding:

- (1) Get an *SX-V DEMONSTRATION KIT* with which to practice.
- (2) Get a copy of *UNDERSTANDING YOUR SX-V DEMONSTRATION KIT*.
- (3) Get a copy of the customer's *SX-V OWNER'S MANUAL* and be sure you understand everything contained in it.
- (4) Set up the *DEMO KIT* and all its components and practice all its functions including:
 - a. How to arm and disarm to every level of protection
 - b. Know the difference between each arming level
 - c. Understand the status sounds
 - d. Practice the *BYPASS* feature
 - e. Try arming with a sensor violated to see & hear what happens
 - f. Set a *TEMPORARY ACCESS CODE*
 - g. Become familiar with the alarm sounds, *BURGLARY, FIRE & AUXILIARY*
 - h. Activate the silent *DURESS CODE*
 - i. Be sure you understand all display information on the CPU
 - j. Try a *SENSOR TEST* (level 9)
 - k. Practice changing the *PROGRAMMING* of the CPU
 - l. Check the *ALARM MEMORY* feature

PRE-INSTALLATION SET UP RECOMMENDATION

With an ITI system you have a unique opportunity to "install" much of the system even before you leave your office.

We strongly recommend that you adopt a procedure of completely pre-programming and testing every system in your office a day or two before the installation is scheduled. Dealers that do this have seen a 10% - 20% reduction in the TOTAL time spent. On-site time can be cut by as much as 50%!

Prior to any installation, a House Code Test should be performed. This test includes leaving the sales demo control panel of the same frequency in the operate mode for approximately 60 minutes to "listen" for any other systems within range. The SX-V has a memory buffer that will store the House Codes of any contending systems and this information can be retrieved and printed out through an ITI CS-4000 Central Station Receiver. This will assure no contention of House Codes.

Set up a test bench in your office with all the proper tools and equipment including; a non-switched 110 volt outlet, an RJ-31X (CA 38A) jack and a Phone Jack Siren. Power up and program the CPU, Touchpads and sensors as if you were at the job site.

Failure to install and program the CPU and accessories as described in the manual for U.L. Listed applications is a violation of the listing mark.

SX-V FEATURES SUMMARY

Receiver

The SX-V CPU contains an extremely sensitive, crystal controlled superhetrodyne receiver which is capable of receiving signals from over 500 feet away, open field. The band width is approximately 100 times narrower than previous models which reduces the chance of interference from other sources. In addition, the dual antenna spatial diversity receiver virtually eliminates phase nulls and dead spots.

Frequency

The SX-V's Central Processing Unit (main security control panel) and all associated devices (transmitters, motion sensors, Touchpads & sirens) used in an installation must all have the same frequency to communicate to each other. The frequency is set at the factory and is marked on all components.

House Code

A House Code is a programmable electronic password that combined with the frequency allows the SX-V and all of its components to communicate. The SX-V system has the ability to recognize 255 individual House Codes (1-254 for installed systems and 255 set aside for demonstration kits only). You must program the House Codes for the Central Processing Unit, Wireless Touchpad, Wireless Interior Siren, and All Transmitters. The section of this manual called Programming the SX-V and ITI Programming instructions have details.

ONCE THE FREQUENCY AND THE HOUSE CODE HAVE BEEN CHOSEN FOR A PARTICULAR JOB, EVERY DEVICE INSTALLED ON THE JOB MUST BE PROGRAMMED WITH THE SAME INFORMATION.

Full Time Sensors

Activation of the sensors listed below will cause an alarm 24 hours a day.

- All emergency push buttons on the touchpad

- Fire and Smoke sensors

- Environmental Sensors (Gas, Freeze, Furnace Failure, etc.)

- 24-hour police emergency sensors (usually portable panic buttons)

- 24-hour medical emergency sensors (usually portable panic buttons)

SIREN sounds

The SX-V CPU initiates a variety of alarm and system status sounds. Sounds can be produced by the Wireless Interior Siren, Hardwire Interior Siren, Hardwire Touchpad display and Hardwire Interior Siren. Not all sounds are produced by all siren types. Sections of this manual which describe the various sirens, identify the sounds they can make. Both alarm siren sounds and status “beeps” can be made to sound throughout the installation site.

INTERIOR AND EXTERIOR SOUNDS

POLICE SIREN - loud intermittent tone siren sound.

FIRE SIREN - loud steady tone siren sound.

INTERIOR SOUNDS ONLY

AUXILIARY SOUNDS - low volume, on-off on-off beeping.

STATUS SOUNDS - low volume beeps which indicate the CPU’s current protection level.

PROTEST BEEP - low volume rhythmic two-tone beeping sound when an arming attempt is made which indicates a Trouble or Supervisory condition or that a sensor is open.

TROUBLE OR SUPERVISORY BEEPS - six quick low volume beeps repeated every sixty (60) seconds. Occurs as an automatic indicator if a trouble or supervisory condition exists and no change occurred in arming level for 10 hours.

CHIME BEEP - a pair of low volume tone which indicates a perimeter sensor has been opened and the CPU is armed to protection level 2.

SENSOR TEST SOUND - loud single tone or series of tones heard when testing sensors in protection level 9.

EXIT DELAY SOUNDS - Low volume status sounds which indicate the beginning of the Exit Delay Time when levels 3 - 6 are selected. Can be programmed to sound repeatedly for the duration of the Exit Delay Time by programming F00 into the CPU.

ENTRY DELAY SOUNDS - Low volume repeated status sounds which indicate that the Entry Delay Time is in progress.

PROTECTION LEVELS

The SX-V system has several arming levels. Each needs to be understood.

- Level 0** **DISARM/CANCEL** - (One long beep)
All intrusion sensors off, full time sensors (fire, medical, panic and environmental) ON.
- Level 1** **SPECIAL** - (One short beep)
Same as Level "0" but special intrusion sensors (silver drawer, gun cabinet, wall safe, etc.) are active and will remain active through level 7.
- Level 2** **CHIME** - (Two short beeps)
Special Intrusion Sensors plus chime feature (all exterior sensors will cause chime tone when activated).
- Level 3** **EXTERIOR** - (Three short beeps)
Special Intrusion Sensors plus Perimeter Sensors armed with delays. All interior sensors disarmed. Typically used during daytime or early evenings while at home.
- Level 4** **AWAY** - (Four short beeps)
Special Intrusion Sensors plus ALL OTHER intrusion sensors, both interior and exterior, armed with delays. Typically used when house is unoccupied.
- Level 5** **SILENT AWAY** - (Five short beeps)
Same as level four, but silent. No intrusion sirens would sound. NOT recommended if phone line is vulnerable or when anyone is in the home. Sirens would sound if there was a fire, medical emergency, police panic or if the communicator fails to reach the central station after 3 attempts.
- Level 6** **NIGHT** - (One long & one short beep)
Same as level four, but will disarm pre-selected interior sensors to allow free movement within a portion of the protected interior. Typically used to give a home owner full access to bedroom - bathroom area at night. Delay times are active.
- Level 7** **INSTANT NIGHT** - (One long & two short beeps)
Same as level six, but entry and exit delay times are instant. Used during night hours after all expected residents have arrived.
- Level 8** **PHONE TEST** - (One long & three short beeps)
This will send a communications test signal over the phone lines to the Central Station. Test is acknowledged at residence either by activation of each siren sound for 2 seconds or a personal phone call from the Central Station Operator.
Note: Level 8 changes to level 0 after successfully communicating to the receiver. If it fails to reach the receiver after eight (8) tries the CPU will display 96 (fail to communicate).
- Level 9** **SENSOR TEST** - (One long & four short beeps)
This level is used to test each sensor (transmitter). The CPU will acknowledge a successful test by first displaying the sensor number reporting in and then removing it from the sensor number display window scroll on the front of the CPU. The sirens connected to the CPU emit a loud "beep" upon activation.

SENSOR NUMBERING

The SX-V system has 61 zones which can be programmed for any purpose. Each sensor is programmed with a unique sensor or zone number using an ITI Programmer or by connecting it to the CPU. Zone or Sensor Numbers assigned to sensors must also be programmed into the CPU memory.

NOTE: In this manual we will often use the term **SENSOR**. Sensors are simply RF transmitters. We will also use the term **SENSOR NUMBER**, this is simply the zone number of that **SENSOR**.

The Central Processing Unit (CPU) recognizes these different Sensor Numbers as having different functions. For example, some are used for fire, some for intrusion, some for medical, etc.

Before installing a **SENSOR**, first pick an appropriate Sensor Number from 02 to 76. Refer to the following chart. For example, a smoke sensor or rate-of-rise detector would need to be programmed with a Sensor Number from 20 to 27. A medical emergency sensor should have a Sensor Number of either 10 or 11. A delayed entry door should have a Sensor Number of 34 to 37 etc. Sensor Numbers higher than 76 are factory assigned.

The following sensors can be received, displayed at the CPU and reported to the Central Station. The Sensor Numbers of all transmitters used in an installation must be programmed into the CPU memory in order to function.

SENSOR NUMBER	ACTIVE LEVELS	SIREN SOUND	DESCRIPTION
02-03	0 - 8	POLICE	24 HOUR POLICE EMERGENCY AUDIBLE-UNSUPERVISED. For use with ITI's unsupervised Portable Panic Buttons.
04-05	0 - 8	NONE	24 HOUR POLICE EMERGENCY - SILENT - UNSUPERVISED. For use with ITI's unsupervised Portable Panic Buttons.
06	0 - 8	POLICE	24 HOUR POLICE EMERGENCY - AUDIBLE - SUPERVISED. For use with regular transmitters wired to a panic or medical button.
07	0 - 8	NONE	24 HOUR POLICE EMERGENCY - SILENT - SUPERVISED. For use with regular transmitters wired to a panic or medical button.
10-11	0 - 8	AUXIL.	24 HOUR MEDICAL EMERGENCY - UNSUPERVISED. For use with an ITI Portable Panic Button. NOTE: The Central Station operator may use the GROUP command to re-program these zones to make them supervised if you plan to use a fixed panic button wired to a supervised transmitter.
12-17	0 - 8	AUXIL.	24 HOUR ENVIRONMENTAL - SUPERVISED. For furnace failure, flood, freeze, power failure, etc.
20-27	0 - 8	FIRE	24 HOUR FIRE SENSORS.

SENSOR NUMBER	ACTIVE LEVELS	SIREN SOUND	DESCRIPTION
30-33	1-7	POLICE	SPECIAL INTRUSION. For special belongings such as the contents of a silver drawer, gun cabinet or wall safe. Silent in Level 5.
34-37	3-7	POLICE	EXTERIOR DELAYED INTRUSION - SUPERVISED. For delayed entrance doors. Chime in Level 2, Instant in 7, Silent in Level 5. Disarmed during Entry/Exit Delay.
40-47 50-57	3-7	POLICE	EXTERIOR INSTANT INTRUSION. For instant doors & windows. Chime in Level 2, silent in Level 5.
60-63	4-7	POLICE	INTERIOR INTRUSION - MOMENTARY DEVICES. For motion sensors, mats, sound sensors, etc. Disarmed during entry/exit time delay. Silent in Level 5, instant in Level 7.
64-65	4-5	POLICE	INTERIOR INTRUSION - MOMENTARY DEVICES. Same characteristics as 60-63, except disarmed in Levels 6 & 7. Typically used for sensors that are in the bedroom area that must be off at night.
66-67	4-7	POLICE	INTERIOR DELAYED INTRUSION - MOMENTARY DEVICES. Same characteristics as 64-65, except that sensors programmed to these numbers WILL INITIATE AN ENTRY AND EXIT DELAY just like an entry door. This will give the customer who forgets to disarm his system before entering a protected interior are time to disarm the system BEFORE it goes into alarm.
70-72	4-7	POLICE	INTERIOR INTRUSION - INTERIOR DOORS. For interior doors, cabinets, wall safes, jewelry boxes and anything else that opens and closes. Disarmed during entry/exit time delay. Silent in Level 5, instant in Level 7.
73-74	4-5	POLICE	INTERIOR INTRUSION - INTERIOR DOORS. Same characteristics as 70-72, except disarmed in Levels 6 & 7. Typically used for doors & cabinets that are in the bedroom area that must be off at night.
75-76	4-7	POLICE	INTERIOR INTRUSION - INTERIOR DOORS. Same characteristics as 73-74, except that sensors programmed to these numbers WILL INITIATE A DELAY when tripped just like an entry door. This will give the customer who forgets to disarm his system time to disarm the system before it goes into alarm after he enters a protected interior area

NOTES ABOUT SENSOR NUMBERS

All sensor numbers are supervised, except for numbers 02, 03, 04, 05, 10 and 11 which are unsupervised. Unsupervised transmitters can be carried away from the home without supervisory reports being sent to the central station. The only transmitters that ITI makes that are unsupervised are the portable panic button and the wireless touchpads.

Sensors 60-65 and 70-74 will be delayed only if a sensor which initiates a delay (34-37, 66-67, 75-76) is activated first to start the delay. If an intruder entered an unprotected window and then tripped sensor 60-65 or 70-74, the alarm would sound instantly.

SENSOR CONTENTION

The SX-V system virtually eliminates any contention if two or more sensors transmit at the exact same moment. Each transmitter sends multiple rounds of information when in alarm with different timing intervals so the signals can not block each other. In addition, emergency signals for fire and panic are given priority over burglary signals, and all emergencies have priority over supervisory and restoral signals.

PRE-PROGRAMMED SENSORS

The following sensors are pre-programmed in the CPU's memory and do not need to be programmed at installation time. You can, however, delete or reinitialize a pre-programmed sensor according to your customer's specific installation requirements. For a complete description on pre-programmed sensors refer to the programming section.

SENSOR NUMBER	ACTIVE LEVELS	DESCRIPTION
01	0 - 8	BAD SENSOR NUMBER ZZ
77	0 - 8	TOUCHPAD TAMPER
80	0 - 8	ALARM FIRE PANIC
81	0 - 8	ALARM POLICE PANIC
82	0 - 8	ALARM AUXILIARY PANIC
83	8	PHONE TEST
86	0 - 9	ALARM! SILENT DURESS
91	0 - 9	LOW CPU BATTERY
94	0 - 8	RECEIVER TROUBLE
95	0 - 8	CPU BACK IN SERVICE
96	0 - 8	FAIL TO COMMUNICATE
97	0 - 8	NO PHONE LINE

OPTIONAL SENSOR NUMBERS

The following SENSOR NUMBERS are OPTIONAL and need to be programmed into the CPU memory if the installation requires these features. They can also be deleted if a customer decides to have a feature turned off. These features are discussed in detail in the PROGRAMMING section.

SENSOR NUMBER	ACTIVE LEVELS	DESCRIPTION
00	0 - 8	ALARM! BUDDY SYSTEM!
84	0 - 8	OPENING REPORT USER-N
85	0 - 8	CLOSING REPORT USER-N
87	0 - 8	AUTO FORCE ARMED
90	0 - 8	AC POWER FAILURE
92	4 - 7	ALARM! TAMPER LOOP
93	0 - 8	AUTOMATIC PHONE TEST

OPTIONAL FEATURE NUMBERS

The following OPTIONAL FEATURES can also be programmed into the CPU memory. They can also be added from the model CS-4000 Central Station as the other sensors can. All optional features power up "OFF" and must be programmed into the CPU to be "ON". These features are discussed in more detail in the PROGRAMMING section.

FEATURE	DESCRIPTION
---------	-------------

F00	EXIT DELAY SOUNDS
F01	TAMPER POLARITY
F02	EXTERIOR SIREN DELAY
F03	DIGITAL COMMUNICATOR
F04	LOW BATTERY REPORT
F05	SUPERVISORY REPORT
F06	DIALER ABORT
F07	OPEN SENSOR DISPLAY
F10	SIGNAL STRENGTH INDICATOR
F11	INTERIOR SIREN SOUNDS
F12	RESTORAL REPORTING
F13	NOT USED
F14	HOURLY PHONE TEST
F15	SENSOR TAMPER
F16	TROUBLE BEEPS
F17	DIRECT BYPASS TOGGLE

SENSOR NUMBER CHART

SENSOR NUMBER	SENSOR TYPE	ACTIVE LEVELS	SUPER- VISED	SIREN SOUND
01	Bad Sensor Number	0 - 8	No	Silent
02 - 03	Police Panic	0 - 8	No	Loud Intermittent
04 - 05	Police Panic	0 - 8	No	Silent
06	Police Panic	0 - 8	Yes	Loud Intermittent
07	Police Panic	0 - 8	Yes	Silent
10 - 11	Medical Panic	0 - 8	No	Low Level Beep
12 - 17	Environmental (Flood, Freeze, etc.)	0 - 8	Yes	Low Level Beeping
20 - 27	Fire Sensors	0 - 8	Yes	Loud Steady Tone
30 - 33	Special Intrusion 1 (Gun Cabinets, Safe, Etc.)	0 - 7	Yes	Loud Intermittent
34 - 37	Delayed Entrance Intrusion (Entry Doors)	3 - 7	Yes	Loud Intermittent
40 - 47	Instant Exterior Intrusion (Windows)	3 - 7	Yes	Loud Intermittent
50 - 57	Instant Exterior Intrusion (Windows)	3 - 7	Yes	Loud Intermittent
60 - 63	Instant Interior Intrusion (Momentary Device) ¹	4 - 7	Yes	Loud Intermittent
64 - 65	Instant Interior Intrusion (Momentary Device) ¹	4 - 5	Yes	Loud Intermittent
66 - 67	Delayed Interior Intrusion (Momentary Device) ²	4 - 7	Yes	Loud Intermittent
70 - 72	Instant Interior Intrusion (Interior Doors, cabinets, etc) ¹	4 - 7	Yes	Loud Intermittent
73 - 74	Instant Interior Intrusion (Interior Doors, cabinets, etc) ¹	4 - 5	Yes	Loud Intermittent
75 - 76	Delayed Interior Intrusion (Interior Doors, etc) ²	4 - 7	Yes	Loud Intermittent
80,81,82,etc	Pre-programmed Sensor Numbers. See Note 3 below.			

OPTIONAL SENSOR NUMBERS⁴

SENSOR NUMBER	PURPOSE	DESCRIPTION
00	Alarm! Buddy System!	Refer to Page 104 for complete information.
84	Opening Report User N	If the CPU is disarmed a opening report is sent to the central station.
85	Closing Report User N	If the CPU is armed a closing report is sent to the central station.
87	Auto Force Armed	If CPU is armed with a sensor bypassed a forced armed report is sent.
90	AC Power Failure	If the CPU loses AC for over 15 minutes a report is sent to the C.S.
92	Alarm! Tamper Loop	Enter 92 if CPU tamper loop is to be used. See Optional Feature F01 below.
93	Automatic Phone Test	Refer to SX-V Installation Manual.

OPTIONAL FEATURES⁵

FEATURE NUMBER	PURPOSE	DESCRIPTION
F00	Exit delay sounds	Set to have exit delay beeps sound throughout delay time, instead of once.
F01	Tamper Polarity.	CPU tamper loop is N.C. Set to change it to N.O. See also sensor 92 above.
F02	Exterior Siren Delay	Set if you want the exterior siren sounds to delay for 15 seconds.
F03	Local Alarm	Set if this is a local alarm and is <i>not</i> to report to the central station.
F04	Low Battery Report	Low batteries normally report weekly. Set if they are not to report at all.
F05	Supervisory Report	Supervisor reports normally report daily. Set if they are to report weekly.
F06	Dialer Abort	CPU normally reports Violations and Cancels. Set for Violation reports only.
F07	Open Sensor Display	Set if you want open sensors displayed when CPU is in Levels 0, 1 and 2.
F10	Dealer Sensor Test	Set and next Sensor Test will sound one beep for each sensor round received.
F11	Interior Siren Sounds	Set if hardwire interior sirens should sound alarms only, not status beeps.
F12	Restoral Reporting	Set if you want violations to send a Restoral report when the sensor is closed.
F13	Not used	
F14	Hourly Phone Test	Sounds trouble beeps & displays 97 if phone line is dead at time of hourly test.
F15	Sensor Tamper	Normally left off. See SX-V Installation Manual.
F16	Trouble Beeps	Set if Trouble Beeps sound only for Fire Sensors.
F17	Direct Bypass Toggle	Set if you wish customer to be able to directly unypass bypassed sensors.

Note 1 Sensors 60 - 65 and 70 - 74 are instant zones, however they will honor a delay initiated by a delayed sensor.

Note 2 Sensors 66 - 67 and 75 - 76 initiate a delay just like an entrance door.

Note 3 See Installation Manual for description of all the Pre-programmed Sensors.

Note 4 Program Optional Sensors just like any others. See ADDING SENSORS.

Note 5 To add an Optional Feature see OPTIONAL FEATURES.

SX-V CPU

The Central Processing Unit (CPU) is the “brain” of the SX-V security system. Its functions are to monitor and respond to signals from sensors, Touchpads, and other input devices. The CPU keeps track of sensor and system status and identifies any problems. The CPU provides audible and visual indications of the system’s status. Appropriate siren sounds are also controlled by the CPU. When necessary, the CPU can communicate detailed reports to the Central Station. The CPU coordinates all system functions.

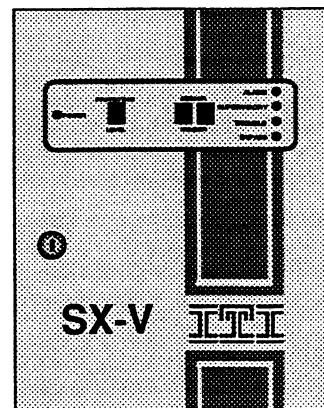

U.L. Listed Systems

The minimum system configurations for the applicable U.L. listed systems are as follows:

- **Basic System**
 - 60-125 SX-V Control Processing Unit
 - 60-193
 - 60-248 Alpha Numeric Touchpad Display
 - 60-136 or 13-046 Hardwire or 60-353 Wireless Siren.
- **Household Fire Alarm**
 - Basic system above and including 60-106 Smoke Sensor
- **Household Burglar Alarm**
 - Basic system above and including 60-135 Door/Window sensor
- **Miscellaneous Signalling**
 - All above systems can use the 60-101 Wireless TouchPad as a signalling device.
- **Home Health Care**
 - Basic system above and including 30-023 "Fail To Execute" Buzzer attached to chassis and wired to pin 10 and 13.

U.L.C. Canadian Approval

<u>Part Number</u>	<u>Description</u>
60-125	SX-V Central Processing Unit
60-276, 60-366	Power Adaptor
60-193	Hardwire Touchpad
60-101	Handheld Touchpad
60-278, 60-441	Hardwire Interior Siren
60-136	Hardwire Interior Siren
60-135, 60-151	Door/Window Sensors
60-363, 60-381	Smoke-Alarms

CSA Certified Accessories

<u>Part Number</u>	<u>Description</u>
60-275	Wireless Interior Siren
60-366	Class II Transformer

SPECIFICATIONS

MICROPROCESSOR BASED CIRCUIT BOARD

The SX-V System is microprocessor based to ensure maximum utility, reliability and versatility. The Microprocessor analyzes data it receives and then acts on the data according to its pre-programmed instructions. System functions are coordinated and directed by the microprocessor.

SX-V RECEIVER

The SX-V uses a quartz crystal accurate Double Conversion superhetrodyne receiver with a 25 KHz bandwidth. The Dual Antenna Spatial Diversity receiver minimizes phase nulls and dead spots, assuring signal reception.

DIMENSIONS

2 7/8"d x 9"w x 11.5"h (+9" antennas) 14 gauge steel chassis, 18 gauge steel door w/lock. The cabinet door can be removed easily by releasing the spring on the hinge and pulling upward. The door will come free for easy access to the panels wiring.

FCC SPECIFICATIONS

FCC ID NUMBER: B4Z8NW-11892-AL-R
RINGER EQUIVALENCE NUMBER: 0.1B

DOC SPECIFICATIONS

LN 14
RADIO EQUIPMENT K442
CERTIFICATE # 8672248A

TEMPERATURE RANGE

32° F to 95° F
0° C to 35° C

AC/DC POWER INDICATOR

The red power LED indicates the following:

STEADY GLOW - AC power is ON

FLASHING ON AND OFF - The AC power is OFF and the backup battery is supplying power.

NOT LIT - The CPU has entered into its memory preservation shut down mode or the power switch has been turned off.

NOTE: When the system is powered by the standby battery, the CPU will shut down all visual status indications except the power indicator after about 15 minutes to conserve power. Pressing the STATUS button on a Touchpad will momentarily light the CPU display (1 - 59 seconds depending on the clock cycle) showing current conditions. An alarm condition will light the display for 5 minutes.

PROTECTION LEVEL DISPLAY

The Protection Level Display window shows the protection level to which the system is armed, from 0 to 9. The window displays "P" any time the CPU is in the Program Mode. The CPU will enter the Program Mode when you turn the Program Mode Switch "ON". Additionally, when setting a Temporary Access Code or when Direct Bypassing sensor numbers, the CPU automatically switches to the Program Mode for a few seconds and then reverts back to the previous protection level after the change takes place.

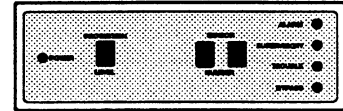

SENSOR NUMBER DISPLAY

The Sensor Number display shows which sensors are: (1) in ALARM, (2) have a SUPERVISORY condition, (3) have a TROUBLE condition, or (4) are BYPASSED. If a sensor has a trouble condition, is bypassed, is in alarm or has a supervisory condition, the sensor number will appear on the display and the appropriate condition LED will light.

The sensor number display also indicates any sensors which are not restored when the customer attempts to arm the system. For example, if a customer attempts to arm his system to LEVEL 3 (exterior) with a door #34 and a window #40 open, the interior sirens would make repeated protest beeps and the numbers 34 and 40 would flash in the sensor number window along with all four LEDs. After seeing which sensors are open, the customer can then go to door number 34 and window 40 and close them. This causes the numbers to clear from the display and the beeping to stop. The customer can now arm the system.

If a sensor has a trouble (usually low battery) or supervisory condition, the problem sensor number and appropriate condition LED will light. Attempting to arm the system will cause "Protest" beeps to sound. To determine whether the protest beeps are due to an open sensor or a problem sensor, watch the condition LEDs. All four flashing indicates a sensor is open, a particular one flashing will identify the cause of the protest. Sensors protesting with a trouble or Supervisory condition can be temporarily silenced by pressing the BYPASS button.

The sensor number display can optionally show the number of open sensors when the CPU is in protection level 0, 1 or 2. This is accomplished by turning ON optional feature number F07. Open sensors can be distinguished from sensors experiencing an alarm, supervisory, trouble or bypass condition because open sensors display their number only, none of the condition LEDs will be lit.

SUPERVISORY INDICATIONS

Every 69 minutes each sensor sends a supervisory signal to the CPU. If no signals have been heard from a particular sensor after approximately 12 hours, the number of the problem sensor is displayed and the "SUPERVISORY" LED is lit. The problem sensor will be reported to the Central Station. It will be re-reported once a day at STIME (or optionally once a week) until the CPU hears from the sensor. The CPU will protest to indicate the supervisory condition as the arming level is changed (except Level 0). Trouble beeps will sound every 60 seconds as an indicator of an existing supervisory condition if no change in arming level has occurred for 10 hours.

Every 12 hours, the CPU checks to see if sensors have reported. The reports to the Central Station can be daily or weekly at STIME, see Programming Section.

Each time the CPU checks for supervisories it looks for and reports all supervisory conditions. The supervisory condition will be removed automatically if the CPU receives a transmission from the missing sensor or if the system is armed to protection level 9.

ALARM MEMORY

The sensor number display can be viewed to determine if there are any alarms in memory. If STATUS is pressed, the system will give an audible indication of its current protection level and the displays will show the sensor number of any sensors which were in alarm during the previous arming period. Sensors which were in alarm are retained in the alarm memory for six hours after the system is disarmed. The alarm memory will be cleared immediately by arming to Level 9.

LINE CARRIER POWER TRANSFORMER

ITI part # 60-145-235 Canada part # 60-366

The power transformer supplies a DC voltage of approximately 13 to 14 VDC (unloaded) to the CPU through terminals 1 & 2. Additionally, it contains the line carrier circuitry for the Wireless Interior Siren through terminal 3. The AC power indicator voltage for the CPU is carried through terminal 4.

The Transformer is fused with a 400 mA fuse on the primary side of the transformer. Replace only with a 400 mA 250V Time Lag Fuse (ITI Part #33-023). The transformer case requires a special tamper bit tool to open. This tamper screw bit is available from ITI. Part # 47-005.

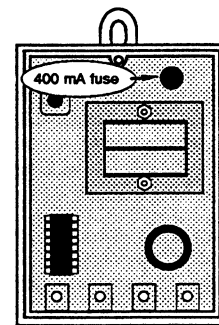

Caution!! Do not operate the transformer with cover removed. Dangerous Voltages are Present!!!

RECHARGEABLE STANDBY BATTERY

ITI Part #34-003

The SX-V uses 6 volt 3.2 amp hour rechargeable lead acid batteries for standby power. The unit is shipped with one battery, but the battery compartment behind the CPU board has room for a second battery. Maximum normal standby current is limited to one 60-248 display and an additional 100mA. Maximum alarm current is 500mA.

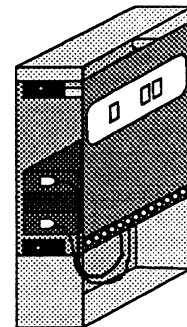

Note: Two batteries are required to meet the 24 hour backup battery requirement.

DIGITAL COMMUNICATOR

The Digital Communicator allows the CPU to transmit over phone lines with Bell 103 format through an RJ-31X (CA38A) jack. The communications format between the CPU and Central Station is interactive (i.e.: CPU programming, system status information and other data can be viewed or changed from the Central Station.) The reporting is done by zone for Alarm, Alarm Cancelled, Supervisory, Trouble, Sensor Bypass and Restorals. The communicator Pulse Dials up to 14 digits if programmed by a Central Station or 11 digits if programmed by a Touchpad.

CPU INSTALLATION

DO

centrally locate the CPU with respect to all sensors.

locate the CPU in an out of the way area yet easily accessible to the customer.

locate the CPU in a heated area of the building (32° F to 95° F).

permanently mount the CPU on a wall .

locate the CPU near eye level so the displays can be easily viewed. Areas such as coat closets or behind the master bedroom door are good locations. Remember to leave enough room for the antennas.

verify the availability of a 110V non-switched AC outlet for the power transformer.

install the RJ-31X (CA38A) jack within 5 feet of the CPU.

avoid locations with excessive metal, such as furnace ducts, foil insulation, pipes and electrical wiring.

locate the CPU on the same or a higher level as most of the sensors.

It is recommended that the CPU display is mounted so that the display is not visible from outside the protected area.

LEVEL AND MOUNT THE CPU

- 1 Open any knockouts for wire feeds.
- 2 Mark the four keyhole mounting slots, and any knockout holes on the wall where the CPU is to be mounted, keep in mind that the CPU antennas extend about 9" above the CPU cabinet.
- 3 MOUNT THE CPU SECURELY, either directly to a stud with 1-1/2" screws or, if a stud cannot be located, with toggle bolts.
- 4 The CPU is heavily protected against power surges and lightning using Metal Oxide Varistors (MOV), Spark Gaps and Transorbs.

CPU CONNECTIONS

The instructions which follow describe CPU connections for power and digital communicator only. A variety of the other devices can be wired to the SX-V CPU. If you will be using any device hardwired to the CPU, refer to the appropriate section of this manual for connection information and wiring diagrams.

All connections to the CPU must be made with the POWER OFF to avoid damaging the CPU.

NOTE: The CPU Power-up procedure is located at the beginning of the PROGRAMMING SECTION.

CAUTION!!! It is important to be free of static electricity whenever working with the cabinet door open. Be sure to discharge any static by first touching the CPU cabinet and stay in contact with the cabinet with one hand whenever touching any component on the board or use a wrist attached ground strap available from electronic supply stores.

- 1 Insert the two antennas through the holes provided in the top of the CPU and tighten the set screws. The antennas should be vertical and clear of metal wires, coat hangers, pipes, duct work, etc.
- 2 Be sure the Master Power Switch & Programming Switch both are OFF (down).
- 3 **With the transformer unplugged and the back-up battery disconnected**, connect ALL 4 WIRES to the CPU as follows:

For wire runs of : 1'-15' use minimum 22 gauge wire
16'-50' use minimum 18 gauge wire.

(DC+)

Transformer Terminal 1 to CPU Terminal 1

(GND/DC-)

Transformer Terminal 2 to CPU Terminal 2

(LINE CARRIER)

Transformer Terminal 3 to CPU Terminal 3

(AC INDICATOR)

Transformer Terminal 4 to CPU Terminal 4

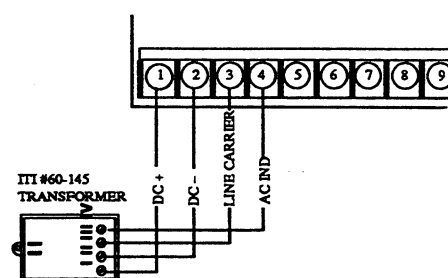

***Do not store any excess wire behind the CPU circuit board.**

***Do not power other equipment from the CPU's transformer.**

- Connect the standby battery leads to the CPU. **POLARITY MUST BE OBSERVED.** THE BATTERY SHOULD CHARGE TO 6.4 VOLTS DC OR ABOVE. The CPU is designed to use only the Panasonic LCR 606 battery for standby power. (ITI Part #34-003)

Battery + lead (red) CPU Terminal 5 (+Batt)
 Battery - lead (black) CPU Terminal 6 (- Batt)

A second battery may be installed in the battery compartment if required. Loosen the two screws and remove the cover to gain access. The second battery must be connected in parallel (ie: directly to the CPU terminal strip with its own leads). Replace the battery compartment cover and tighten the set screws after sliding the battery into place.

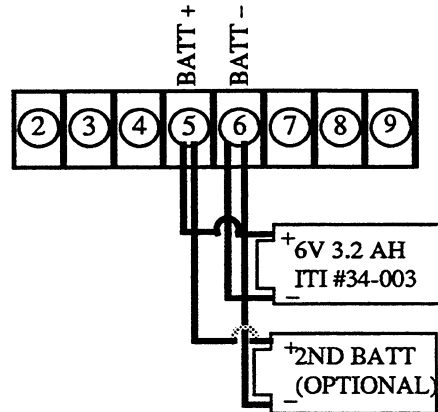

- Connect the RJ-31X (CA38A) cord to the CPU as indicated below.

Terminal 15 (line tip)	to	RJ-31X (CA38A) Cord Green
Terminal 16 (phone tip)	to	RJ-31X (CA38A) Cord Brown
Terminal 17 (phone ring)	to	RJ-31X (CA38A) Cord Gray
Terminal 18 (line ring)	to	RJ-31X (CA38A) Cord Red

- Secure the RJ-31X (CA38A) cord strain relief to the CPU chassis using the screw in the lower right corner of the CPU board.

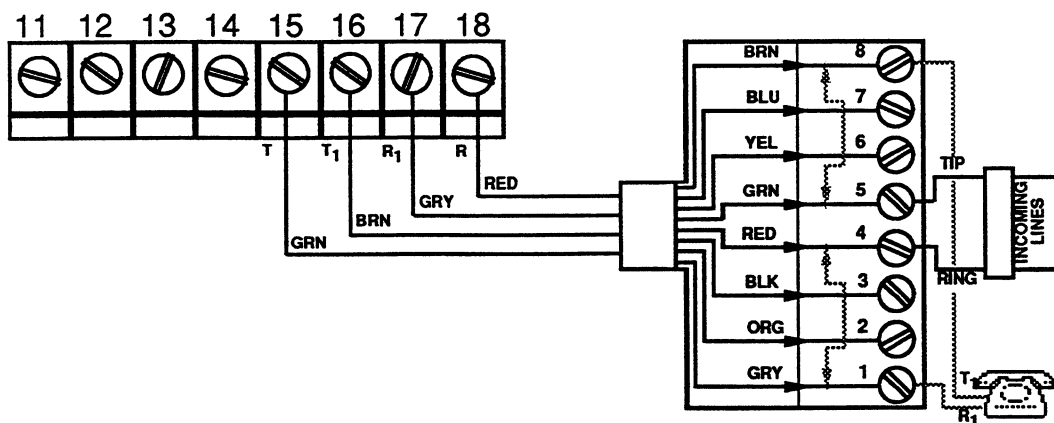

CPU HARDWIRE TAMPER INPUT

The SX-V CPU has a Hardwire Input which can be connected to an Optional tamper switch. With the optional tamper switch installed, opening the door when the CPU is armed to protection Level 3-7 causes the CPU to go into audible police alarm (silent in Level 5) and report a 92 ALARM! TAMPER LOOP to the Central Station. Optionally, other hardwire devices such as a siren tamper or RJ-31X (CA38A) cord tamper can be wired in series into this input. The input is set NORMALLY CLOSED (open on alarm) but can be re-configured to be NORMALLY OPEN (closed on alarm) if necessary. To change from N/C to N/O, see Optional Feature F01.

Refer to the drawings below for tamper connections.

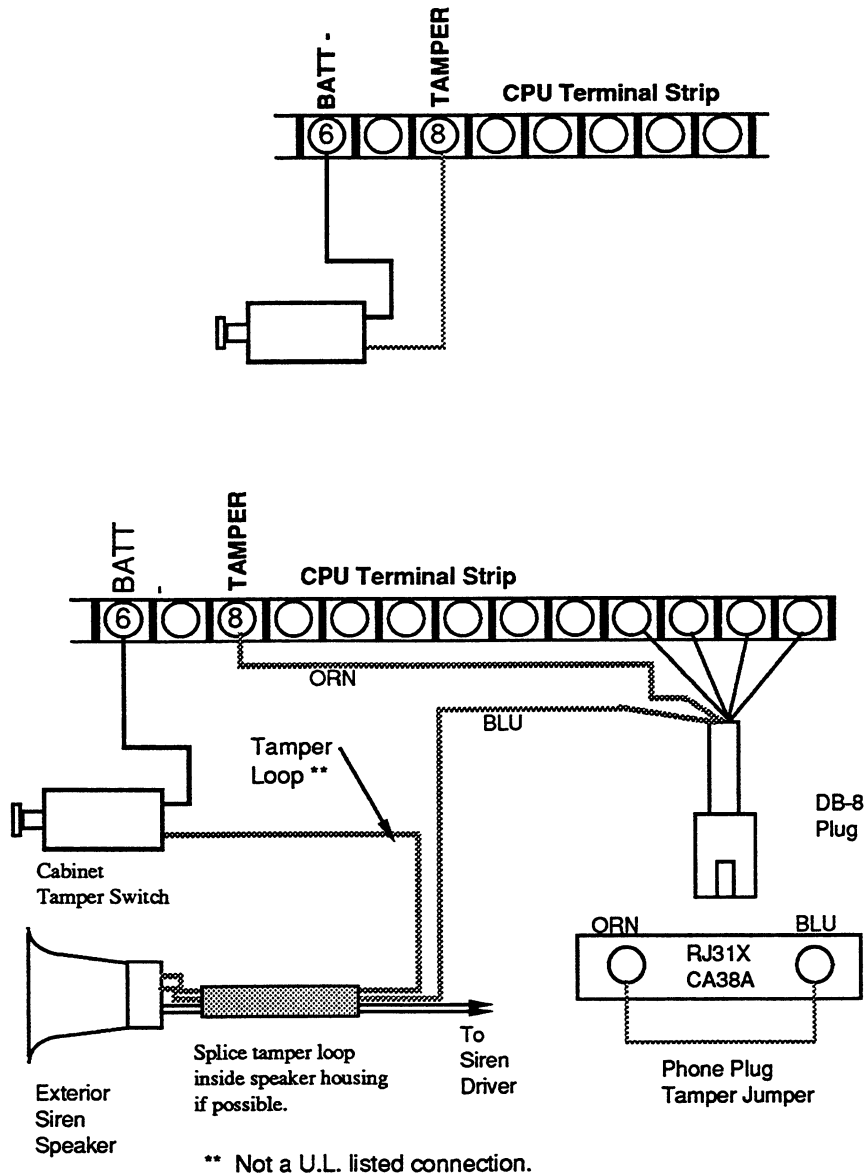

NOTE: Optional Sensor Number 92 must be programmed into the CPU if the tamper input is used.

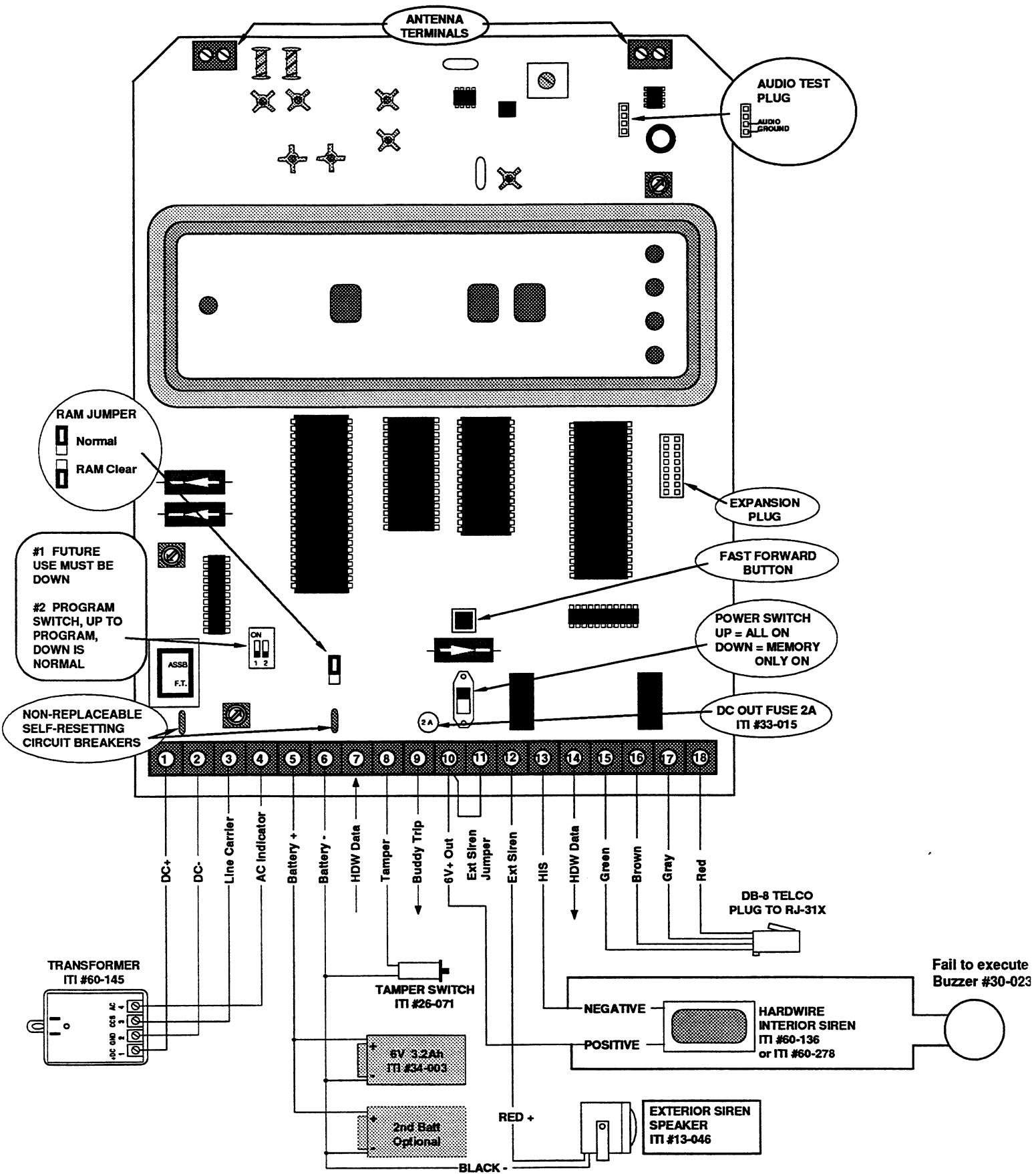

HI-TECH HARDWIRE TOUCHPAD w/ALPHA NUMERIC DISPLAY

ITI Part No. 60-248

The SX-V Hi-Tech Hardwire Touchpad with Alpha Numeric Display is a full function touchpad which includes a 16 character Vacuum Fluorescent Alphanumeric Display for visual system status messages. The unit's display can identify a specific programmed location name which allows the user to easily determine where an Alarm, Trouble or Open Sensor condition exists. Location names can be selected from a list of pre-programmed words or they can be customized by the installer to suit the customer's needs.

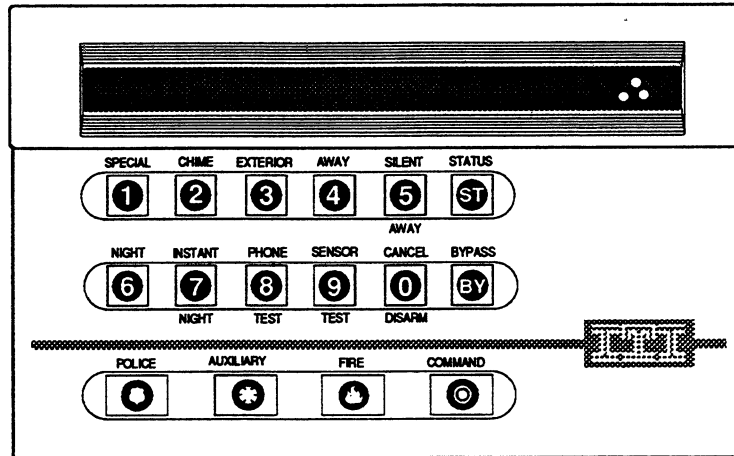

FEATURES

- Display has 4 brightness levels and a black-out option.
- Touchpad keys illuminate after first key press for easy night viewing.
- Built-in piezo emits Alarm/Status tones.
- 24 hour panic buttons for Police, Auxiliary and Fire emergencies.
- Unit accepts one hardwire zone input.

PRELIMINARY CONSIDERATIONS

- Total current draw of the Alpha/Numeric Touchpad Display is 100mA.
- Maximum current draw allowed by the SX-V CPU is 500mA.
- Mount the unit in an environmentally controlled area (42°F to 95°F).
- Mount the unit near the area where you plan to utilize the optional Hardwire Input.
- Use 4 conductor, 22 gauge or greater stranded wire from the display to the SX-V CPU.
- Use 2 conductor, 22 gauge or greater stranded wire for the optional Hardwire Input.
- Do not exceed 100' of wire length.

Gang Box Mounting

1. Separate the Back Plate from the display by pressing the Release Tab and pulling it down.
2. Place the Back Plate on the gang box so that the 4 inner slots on the Back Plate line up with the 4 outer holes of the gang box.
3. Secure the Back Plate to the gang box using #6 x 1/2" or #6 x 3/4" panhead screws.

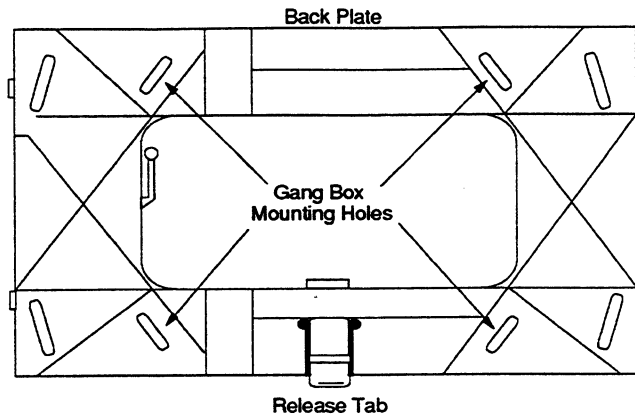

CAUTION! Do not use screws larger than #6 or the display will not seat properly onto the Back Plate. Also, do not over tighten screws or the Back Plate may bind and not allow the display to mount properly.

Wall Mounting

1. Separate the Back Plate from the display by pressing the Release Tab and pulling it down.
2. Place the Back Plate at the desired location on the wall and use a pencil to mark the Wall Mount Holes.
3. Insert anchors suitable for #6 screws at the marked locations.
4. Position the Back Plate so that the Wall Mount Holes line up with the anchors in the wall.
5. Secure the Back Plate to the wall using #6 x 1/2" or #6 x 3/4" screws. Do not use screws larger than #6 or the display will not seat properly onto the Back Plate.
6. Cut a hole in the wall along the inner right edge of the Mounting Plate to pull your cable through for terminations.

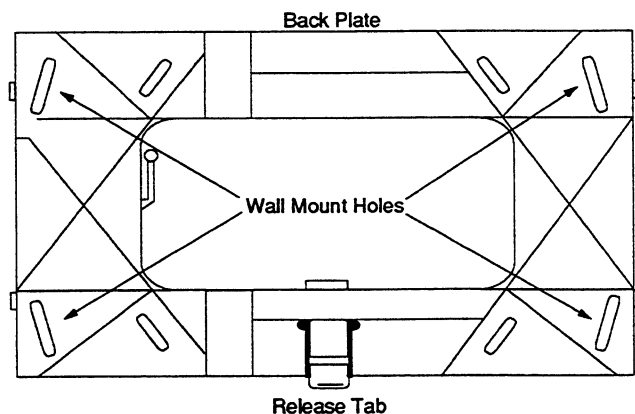

Wiring

1. If the SX-V is powered up, set the protection level to 0 and turn the power switch off.
2. Follow the diagram below for proper termination of the Wire Harness to the SX-V CPU.
3. Insert the Wire Harness onto the pins located on the rear of the unit. Make sure the Yellow wires are positioned on the two bottom pins.
4. Leave the jumper on the top two pins.
5. Attach the display to the mounted Back Plate by lining up the wide portion of its four Tab Slots with the four Tabs on the Mounting Plate. Once aligned, slide the display downward until you hear the Release Tab "click" into place.

Note: All wiring shall be recognized energy limited cable, 22AWG minimum.

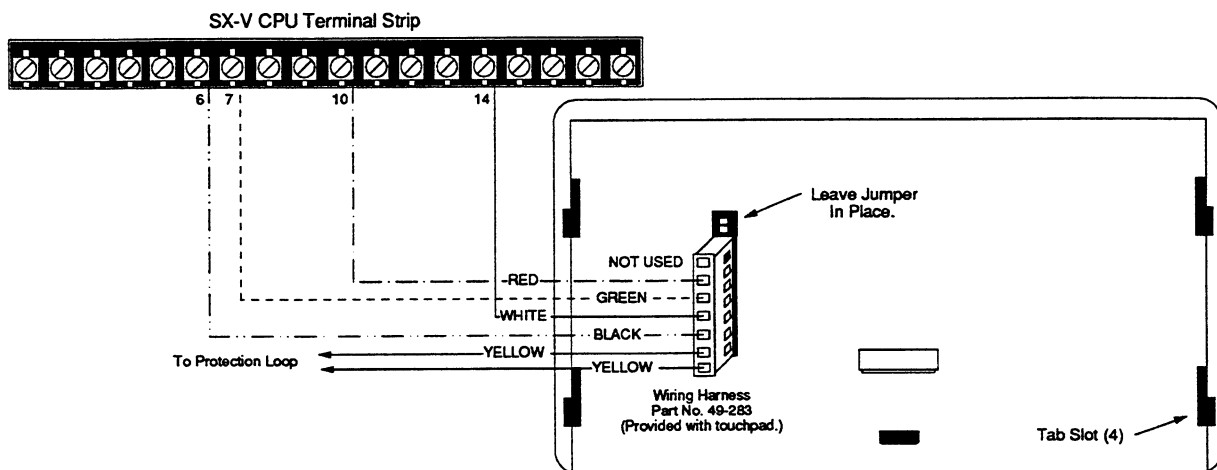

Protection Loop Notes

If the loop is used and programmed Normally Closed, the touchpad shall be mounted within 3 feet of the CPU.

If the loop is programmed Normally Open, the CPU, touchpad and initiating devices shall be mounted within 3 feet of each other. No interfering walls or barriers shall be present between the devices.

Only U.L. Listed devices shall be connected to the loop.

The loop shall not be used for fire initiating devices.

POWER UP

Programmed CPU

1. Check wiring for proper terminations.
2. Turn the SX-V power switch ON. The CPU display should read as illustrated below.
3. The Alpha/Numeric Display should power up with all segments ON for about 12 seconds. After 12 seconds the display will perform two self tests.
4. First, the display will scroll the letters of the alphabet starting at the right of the display.
5. After the letter "Z" appears, the display will show the message **KEY TEST** . Press any key and the display will show which key was pressed. For example, press  and the display will show **KEY TEST-FIRE** . Press each key to verify its operation. After about five seconds of no key pressing the display will show **TEXT MEMORY OK** and then display as illustrated below.

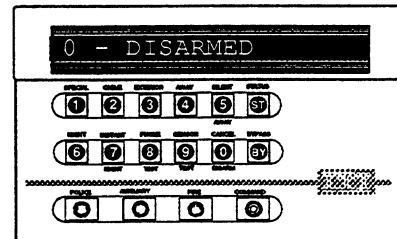
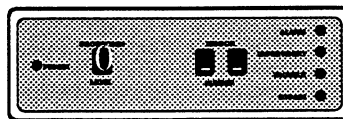

Unprogrammed CPU

1. Check wiring for proper terminations.
2. Turn the SX-V power switch ON.
3. The SX- V CPU will perform its RAM Check function. During this time the Alpha/Numeric Display will show all segments ON for about 12 seconds and then go blank.
4. After the SX-V completes its RAM check, the CPU display should read as illustrated below. The touchpad display will show all segments ON, then perform two self tests.
5. First, the display will scroll the letters of the alphabet starting at the right of the display.
6. After the letter "Z" appears, the display will show the message **KEY TEST** . Press any key and the display will show which key was pressed. For example, press  and the display will show **KEY TEST-FIRE** . Press each key to verify its operation. After about five seconds of no key pressing the display will show **TEXT MEMORY OK** and then display as illustrated below.

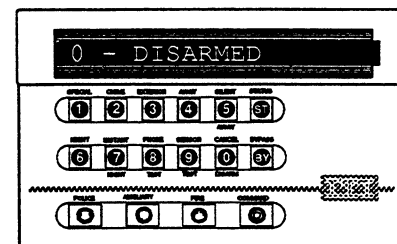
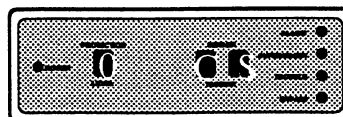

If you have more than 1 Alpha Numeric Touchpad connected to the CPU, work from 1 touchpad for all programming. Once you have completed all programming, the information from this touchpad can be downloaded to the others. The download procedure will be covered later in this section.

IMPORTANT! If you have more than 1 touchpad connected to the CPU, you must first program each one with a different Unit I.D. number. See page 29 for this procedure. In cases where the Unit I.D. numbers are identical (such as units out of the box from the factory), the procedure may have to be done twice. Failure to change identical Unit I.D. numbers can cause the touchpads to malfunction during normal operation.

1. Turn the CPU Program Switch (#2) ON. The Alpha Numeric display should read as follows:
2. Press and hold the CPU Fast Forward Switch until you hear the piezo in the display activate or wait for all programmed sensor numbers to cycle through 1 time on the CPU display. After all sensors have cycled, the piezo in the Alpha Numeric Display will activate. The display should read as follows: ("X" is a letter from A-Z indicating touchpad software version.)

The Alpha Numeric Touchpad Display can now be used to program the SX-V system features, sensor numbers and names. The unit's piezo will beep 6 times every 60 seconds to remind you that the CPU is in the program mode.

Note: The panel's alarm functions are not operational with the CPU/touchpad in the programming mode.

KEY FUNCTIONS for PROGRAMMING

Before proceeding, it is important to know the function of each key when programming. Study the key functions listed below, then examine the flow chart on the next page to familiarize yourself with the sequence in which the programming procedures appear.

 **BY** Cycle Forward

 **ST** Cycle Backward

 **Execute** Proceed/Execute

 **Abort/Exit**

 **Delete This Entry and Move Remaining Entries Up One Slot***

 **Insert This Entry and Move Remaining Entries Down One Slot***

 **0 - 9** Face Value or Word/Letter Numbers

* These features used only when programming sensor names.

PROGRAMMING FLOW CHART

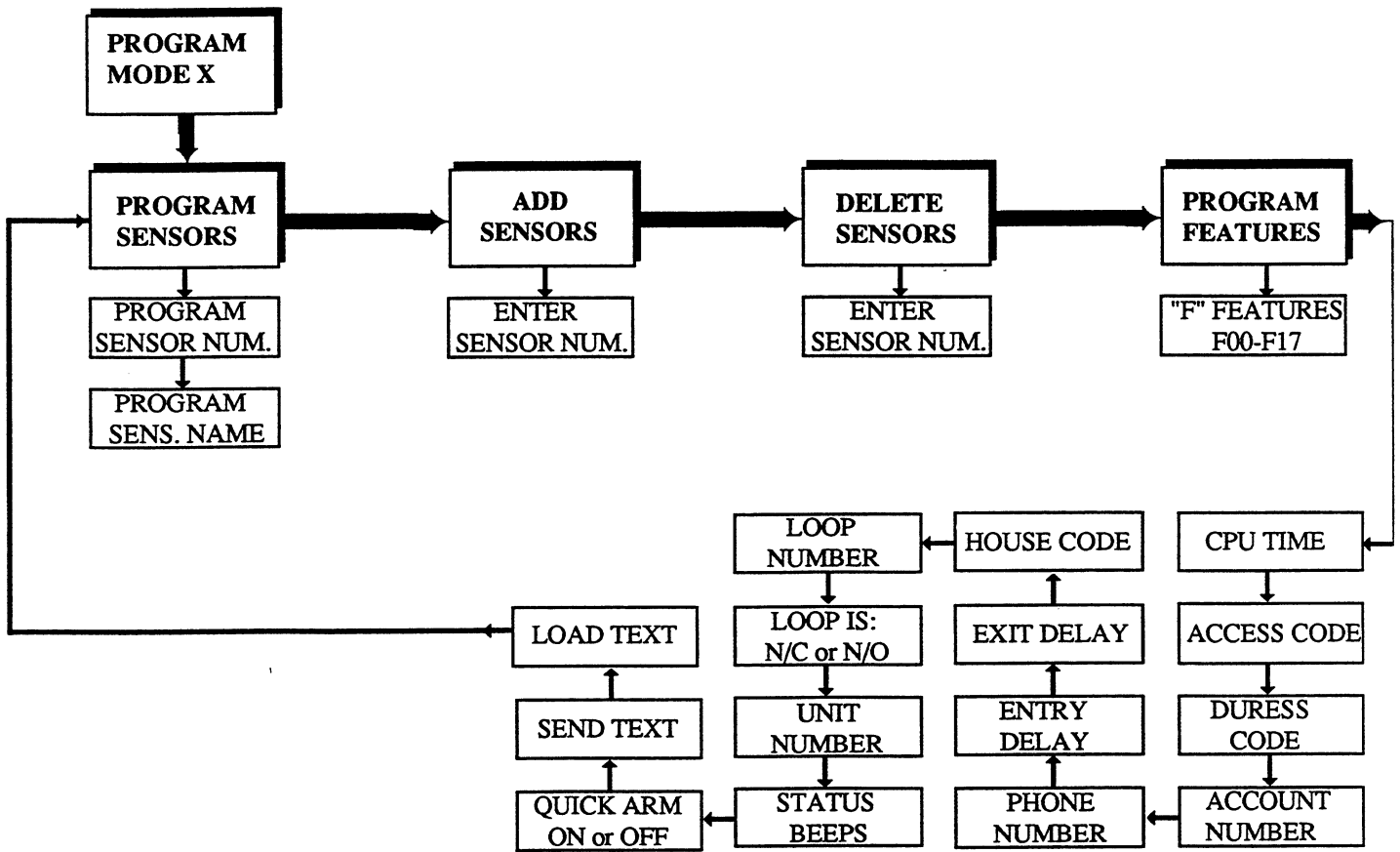

As indicated by the flow chart, the first procedure to appear is for Sensor Programming. Once the sensor number has been entered, the sensor name can be programmed using any of the characters or names described in the chart on the page below.













Each sensor number contains 9 word or character locations to program its name. These locations are lettered A through I and require a 2 digit entry (from the chart on the page below) to set the desired words and/or characters.

The example on the right side of this page shows the procedure for programming sensor 34 as the FRONT DOOR. Notice in this case only locations A & B are used to name the sensor. Spaces are automatically inserted after each word when using 40-99 and do not occupy any locations. This example leaves 7 unused locations (C-I) for this sensor's name. Not all locations need to be used.

In most cases the words in the chart (40-99) will be sufficient. Should you need to create a word using individual characters, remember each character (01-39) uses one location. Use the worksheet on page 13 to determine all sensor name programming ahead of time.

Helpful Hint: When using characters (01-39), abbreviate where possible or generalize instead of being specific. For example, if two brothers are sharing a bedroom, it is unlikely you could program both their names to identify the sensor in their room without running out of locations. A good choice would be to create the word BOY'S using locations A-E, then use location F for a Space, location G for the word BEDROOM and location H for the word WINDOW. (See worksheet on page 13 for this example.)

SENSOR PROGRAMMING EXAMPLE

1. Press , display reads **PROGRAM SENSOR**
2. Press , display reads **PRG 01 --SENSOR IN**
3. Press , display reads **PRG**
4. Enter  , display reads **PRG 34**
5. Press , display reads **A 00**
6. Enter  , display reads **A 62 FRONT**
7. Press , display reads **B 00**
8. Enter  , display reads **B 53 DOOR**
9. Press , display reads **ADD 34 FRONT DOOR**
10. Press , display reads **ADD 34 DONE**

To review the programming, press .

To continue programming sensors press  again and repeat the procedure above beginning at step 2.

If you enter a wrong number at steps 5 or 7, simply re-enter the desired number.

This procedure assumes the sensor number being programmed does not already exist in the SX-V CPU memory. Therefore, both the CPU and the display are programmed simultaneously.

Character	Entry	Character	Entry	Character	Entry
Null	00	M	13	(Space)	27
A	01	N	14	' (Apostrophe)	28
B	02	O	15	- (Dash)	29
C	03	P	16	0	30
D	04	Q	17	1	31
E	05	R	18	2	32
F	06	S	19	3	33
G	07	T	20	4	34
H	08	U	21	5	35
I	09	V	22	6	36
J	10	W	23	7	37
K	11	X	24	8	38
L	12	Y	25	9	39
		Z	26		

Word	Entry	Word	Entry	Word	Entry
AREA	40	FLOOR	60	PATIO	80
ATTIC	41	FREEZE	61	POLICE	81
BASEMENT	42	FRONT	62	POOL	82
BATHROOM	43	GALLERY	63	PORCH	83
BEDROOM	44	GARAGE	64	REAR	84
BOTTOM	45	GUN	65	ROOM	85
BREEZEWAY	46	HALL	66	SAFE	86
CABINET	47	HEAT	67	SCREEN	87
CARPET	48	KITCHEN	68	SECOND	88
CLOSET	49	LAUNDRY	69	SENSOR	89
DEN	50	LEVEL	70	SHOCK	90
DESK	51	LIBRARY	71	SIDE	91
DINING	52	LIVING	72	SLIDING	92
DOOR	53	MAIN	73	SMOKE	93
DRAWER	54	MAT	74	SOUND	94
EAST	55	MEDICAL	75	SOUTH	95
ENTRY	56	MOTION	76	STAIRS	96
FAMILY	57	NORTH	77	TOP	97
FIRE	58	OFFICE	78	WEST	98
FIRST	59	PANIC	79	WINDOW	99

REVISION E		PREVIOUS REVISIONS		
Word	Entry	Word	Entry	
HALL	65	GUN	65	This table displays the word list changes between Revision E touchpad software and previous touchpad software revisions.
HEAT	66	HALL	66	
KITCHEN	67	HEAT	67	
LAUNDRY	68	KITCHEN	68	
LEVEL	69	LAUNDRY	69	
LIBRARY	70	LEVEL	70	
LIVING	71	LIBRARY	71	
MAIN	72	LIVING	72	
MASTER	73	MAIN	73	

PROGRAMMING NOTES

- Each time the CPU Program Switch is turned ON, the touchpad is forced to "learn" the sensor numbers and features already programmed into the CPU memory. The more sensors and features that are programmed, the longer the learning process. Pressing the CPU Fast Forward Switch accelerates the "learning" process but is not necessary.
- When programming sensor names, notice that all locations (A-I) default to 00. Enter 00 whenever you want to delete a character or word from the sensor's name.
- Remember to add spaces (27) where necessary when programming individual characters (01-39) to create custom words. Each programmed space uses one location (A-I).
- Spaces are automatically inserted (after the word) when programming words (40-99) and do not use up any locations.
- Sensor numbers which are deleted using the Alpha Numeric Touchpad *will not keep their sensor name* when added back into the CPU memory.
- Sensor numbers which are deleted using a Wireless Touchpad *will keep their sensor name* if added back to the CPU memory. When adding the sensor back into memory, use the ADD SENSORS procedure if using the Alpha Numeric Touchpad or re-initialize the sensor number using a Wireless Touchpad.
- To disable the optional Hardwire Loop (page 12) enter 00.

ADD SENSORS

This procedure is ideal for programming sensor numbers with pre-programmed names which *cannot be changed*. These sensor numbers are: 00-01, 77, 80-87 and 90-97. The name of the sensor number will automatically appear in the display after entering the sensor number in step 4.

Pressing the **BY** or **ST** buttons while in this mode will cycle all sensors which are *not initialized*. Step 2 will always display the *lowest sensor number not programmed*.

1. Press **BY** or **ST** until display reads
2. Press **⊙**, display reads **ADD 00 BUDDY REP**
3. Press **ST**, display reads **ADD**
4. Enter **8 4**, display reads **ADD 84 OPENING**
5. Press **⊙**, display reads **ADD 84 DONE**

CHANGE / EDIT A SENSOR NAME

Use this procedure to change or edit a sensor's name which is already programmed.

1. Press **BY** or **ST** until display reads **PROGRAM SENSORS**
2. Press **⊙**, display reads **PRG 01 SENSOR IN**
3. Press **ST**, display reads **PRG**
4. Enter **3 4**, display reads **PRG 34 FRONT DOO**
5. Press **⊙**, display reads **A 62 FRONT**
6. Enter **8 4** display reads **A 84 REAR**
7. Press **👉**, display reads **PRG 34 REAR DOOR**

Since the sensor number already existed in both the CPU and touchpad memory, the display will not prompt you to **ADD** the sensor.

DELETE SENSORS

This procedure deletes the sensor number from the SX-V CPU and deletes the sensor number and name from the Alpha Numeric Display's memory.

Pressing the **BY** or **ST** buttons while in this mode will cycle all sensors which *are initialized*. Step 2 will always display the *lowest sensor number which is programmed*.

1. Press **BY** or **ST** until the display reads
2. Press **⊙**, display reads
3. Press **ST**, display reads
3. Enter **4 0**, display reads
4. Press **⊙**, display reads

PROGRAMMING CPU OPTIONS

Press **BY** or **ST** until the display reads PROGRAM FEATURES.
The CPU Options will appear in the sequence shown below.

If you don't need to program or change an option, press **BY** to cycle forward to the next option.

DISPLAY READS	PRESS	DISPLAY READS	ENTER	PRESS	DISPLAY READS	PRESS	PRESS	
PROGRAM FEATURES	⊙	FEATURE 00 OFF	00-17	⊙	FEATURE 00 ON	⊙	BY	To Continue
CPU TIME 1200	⊙	SET TIME	0000-2359	⊙	SET TIME DONE	⊙	To Review BY	To Continue
ACCESS CODE	⊙	ENTER CODE	Any 4 Digits	⊙	ENTER CODE DONE	⊙	BY	To Continue
DURESS CODE	⊙	ENTER CODE	Any 2 Digits	⊙	ENTER CODE DONE	⊙	BY	To Continue
ACCOUNT NUMBER	⊙	ENTER NUM	Any 5 Digits	⊙	ENTER NUM DONE	⊙	BY	To Continue
PHONE NUMBER	⊙	PHON	7 to 11 Digits	⊙	PHON DELAY DONE	⊙	BY	To Continue
ENTRY DELAY	⊙	ENTRY DELAY	04-60 Seconds	⊙	ENTRY DELAY DONE	⊙	BY	To Continue
EXIT DELAY	⊙		04-60 Seconds	⊙	EXIT DELAY DONE	⊙	BY	To Continue

DISPLAY READS	PRESS	DISPLAY READS	ENTER	PRESS	DISPLAY READS	PRESS	PRESS
HOUSE CODE 000		ENTER CODE	001-254		PRESS CPU FF SW		To Continue
*LOOP DISABLED		ENTER NUM	02-76		HOUSE CODE DONE		To Continue
LOOP IS NC		LOOP IS NO			ENTER NUM		To Continue
UNIT NUMBER		ENTER UNIT	0-7				To Continue
STATUS BEEPS OF		STATUS BEEPS ON			ENTER UNIT DONE		To Continue
QUICK ARM ON		QUICK ARM OFF					To Continue

*Note: To delete a sensor number entered into the LOOP DISABLED location, enter 00.

SENSOR #	SENSOR NAME	CHARACTER/WORD ENTRIES								
_____	_____	A	B	C	D	E	F	G	H	I
_____	_____	A	B	C	D	E	F	G	H	I
_____	_____	A	B	C	D	E	F	G	H	I
_____	_____	A	B	C	D	E	F	G	H	I
_____	_____	A	B	C	D	E	F	G	H	I
_____	_____	A	B	C	D	E	F	G	H	I

This feature will send all sensor message text from the programmed Alpha Numeric Touchpad to any others connected to the CPU. Follow the procedure below.

1. Press , display reads **SEND** the **SEND RDY** .
2. Press or on all unprogrammed touchpads until they read **LOAD TEXT** .
3. Press on all unprogrammed touchpads. The displays should read **LOAD** the **LOAD SN** .
4. Press on the programmed touchpad. The display will cycle all sensors beginning at 02 and ending at 76
5. The unprogrammed displays will cycle all sensors beginning at 02 and ending at 76
6. When all information is sent, the programmed display will read **SEND DONE** and the other displays should read **000 ERRS** . If any display indicates errors, repeat steps 1-5. If any display still indicates errors, contact ITI Tech Services at 1-800-777-2624.

PRE-PROGRAMMED SENSOR NAMES

The following list shows the sensor numbers with names which *cannot be changed or edited*. The names will appear with the sensor number on the display as shown below.

00 BUDDY REPORT	01 SENSOR IN RANGE
77 TOUCHPAD TAMPER	80 FIRE ALARM
81 POLICE ALARM	82 AUXILIARY ALARM
83 PHONE TEST	84 OPENING REPORT
85 CLOSING REPORT	86 DURESS
87 FORCED ARMED	90 AC FAILURE
91 LOW CPU BATTERY	92 CPU TAMPER
93 AUTO PHONE TEST	94 RECEIVER TROUBLE
95 CPU BACK IN SERVICE	96 FAILURE TO COMMUNICATE
97 NO PHONE LINE	

OPTIONAL FEATURE NUMBERS

All optional features power up OFF and must be programmed ON to activate the desired feature (see page 11). Refer to your SX-V Installation Manual (part no. 46-074) for a complete description of each feature.

F00 EXIT DELAY SOUNDS	F10 SIGNAL STRENGTH INDICATOR
F01 TAMPER POLARITY	F11 INTERIOR SIREN SOUND
F02 EXTERIOR SIREN DELAY	F12 RESTORAL REPORTING
F03 DIGITAL COMMUNICATOR	F13 NOT USED
F04 LOW BATTERY REPORTS	F14 HOURLY PHONE TEST
F05 SUPERVISORY REPORTS	F15 SENSOR TAMPER
F06 DIALER ABORT	F16 TROUBLE BEEPS
F07 OPEN SENSOR DISPLAY	F17 DIRECT BYPASS TOGGLE

PROTECTION LEVELS

- LEVEL 0 - CANCEL/DISARM 24 hour & sensors 12-17, 20-27 ON, all other sensors off.
- LEVEL 1 - SPECIAL Same as Level 0, plus sensors 30-33 ON.
- LEVEL 2 - CHIME Same as Level 1, plus sensors 34-57 chime when opened.
- LEVEL 3 - EXTERIOR 24 hour and sensors 12-17, 20-27, 30-33 & 40-57 ON.
- LEVEL 4 - AWAY Same as Level 3, plus 60-76 ON.
- LEVEL 5 - SILENT AWAY Same as Level 4 except no Burglary siren sounds.
- LEVEL 6 - NIGHT Same as Level 4 except 64-65 & 73-74 OFF.
- LEVEL 7 - INSTANT NIGHT Same as Level 6 except NO DELAY on 34-37.
- LEVEL 8 - PHONE TEST Tests communication from SX-V CPU to Central Station.
- LEVEL 9 - SENSOR TEST Tests communication from sensors to SX-V CPU.

NOTE: Regrouped sensor numbers will not arm or disarm according to the above information.

SYSTEM STATUS

The Protection Level number on the display will flash to indicate one or more of the following conditions exist:

ALARM CONDITION
ALARM IN MEMORY
OPEN SENSOR*

BYPASSED SENSOR
TROUBLE
SUPERVISORY

The built-in piezo will emit the following tones when the system is armed or disarmed:

1 BEEP - Level 1
2 BEEPS - Level 2
3 BEEPS - Level 3
4 BEEPS - Level 4
5 BEEPS - Level 5

1 LONG, 1 SHORT BEEP - Level 6
1 LONG, 2 SHORT BEEPS - Level 7
1 LONG, 3 SHORT BEEPS - Level 8
1 LONG, 4 SHORT BEEPS - Level 9
1 LONG BEEP - Level 0

Press **ST** once to read condition messages. Press **ST** twice to read Alarm Memory messages and to hear current Protection Level *beeps*.

If the system is in alarm, pressing **ST** once will display the number and name of those sensors in alarm only.

* Open sensors display only if F07 is ON.

ACCESS CODE ARMING/DISARMING

The four digit Access Code allows the user to arm the system to any protection level. The Alpha Numeric Display will show the protection level number and name after successful arming.

After successfully arming to levels 3-7, the Alpha Numeric Touchpad will briefly display an exit message and then show the protection level name. For example, arming to level 4 will look like this:

Enter 4 digit Access Code + 4.

Display reads **4 OK TO EXIT NOW** then **4 AWAY**

Successful arming to level 7 will look like this:

Enter 4 digit Access Code + 7.

Display reads **7 GOOD NIGHT** then **7 INSTANT NIGHT**

To disarm the system:

Enter 4 digit Access Code + 0.

Display reads **0 DISARMED**

QUICK ARM

If the Quick Arm option is enabled (page 12) the COMMAND button allows any user to arm the system in the following manner:

FROM: Level 0 to Levels 1-7
 Level 1 to Levels 2-7
 Level 2 to Levels 3-7

The COMMAND button cannot be used to lower the protection level or to perform a phone or sensor test.

Once in Level 3, the COMMAND button will not allow the user to arm to a higher level.

Only the Access Code can be used to change the protection level once the system is armed to Level 3 or higher.

Open or protesting sensors *cannot be bypassed* when arming with the COMMAND button (see Sensor Protest on page 18).

With the system in Level 0, use the COMMAND button to arm the system to any level from 1-7. For example, to arm the system to Level 4:

Enter  + 

Display reads **4 OK TO EXIT NOW** then **4 AWAY**

SENSOR PROTEST

A protest condition is intended to alert the user of a sensor which is not in a normal state, such as Open, Trouble or Supervisory. Sensors in any of these states during an arming attempt (using the Access Code) will protest the arming command.

During a protest condition, the piezo in the Alpha Numeric Touchpad will emit 6 rapid beeps continuously and the display will alternate flashing the current protection level and the protest condition.

Pressing  once will display the state of the sensor, the sensor number and its name. The user then has two options to consider:

1. Change the protesting sensors to their normal state and re-arm.
2. Bypass the protesting sensor(s).

Bypass means to leave a sensor in a non-protection mode while other parts of the system are still armed. Any bypassed sensor can be activated without triggering an alarm condition. There are two methods in which to Bypass sensors described at right.

Indirect Bypassing allows the user to bypass only those sensor numbers from 34-57 which protest upon an arming attempt. After pressing STATUS to determine the state of protesting sensors, the user must wait for the touchpad to return to the *main protest display* before a successful Indirect Bypass attempt (#2 at right).

Direct Bypassing allows the user to bypass a sensor after the system is armed.

BYPASSING SENSORS

Indirect Bypass (Bypass Protecting Sensors 34-57 Only)

Example: Open sensor 40 - Bedroom Window.

1. With the system in Level 0, enter Access Code + **6**
2. Display reads **0 DISARMED** then **0 PROTEST**
3. Press **BY** .
4. Display reads **6 OK TO EXIT NOW** then **6 NIGHT**
5. Press **ST** . Display will scroll the bypassed sensor number and name. The Protection Level number will flash to indicate there is a bypassed sensor.

Direct Bypass (Bypass A Sensor After Arming)

Example: All sensors closed.

1. With the system in Level 0, enter Access Code + **6**
2. Display reads **6 OK TO EXIT NOW** then **6 NIGHT**
3. Enter Access Code + **BY** . Display reads **BYPASS SN**
4. Enter **4 0**
5. Display reads **BYPASS SENSOR 40** then **BYPASS SN DONE**
6. Display returns to **6 NIGHT**. The Protection Level number will flash to indicate there is a bypassed sensor.

TOUCHPAD PANICS

Each touchpad panic is active 24 hours. Press and hold each panic for about one second to trip the appropriate alarm condition.

Press and hold  . Built-in piezo emits 6 rapid beeps, then slow ON OFF ON OFF siren sounds with Interior and Exterior sirens. Display reads **POLICE ALARM**.

To cancel alarm, enter Access Code + **0** .

Press and hold  . Built -in piezo emits 6 rapid beeps, then fast ON OFF ON OFF siren sounds with Interior sirens only. Display reads **AUXILIARY ALARM**

To cancel alarm, enter Access Code + **0** .

Press and hold  . Built-in piezo emits 6 rapid beeps, then a STEADY tone with Interior and Exterior sirens. Display reads **FIRE ALARM**

To cancel alarm, enter Access Code + **0** .

SENSOR TEST

1. With the system in Level 0, enter Access Code + **9**
2. Display reads **9 SENSOR TEST**
3. As each sensor is tripped, the built-in piezo will beep once and the display will scroll the sensor number and its name.
4. After the CPU has responded to all sensors (including touchpad panics) the display will read **9 SENSOR TEST OK**
5. Enter Access Code + **0**. Display reads **0 DISARMED**

To perform a Signal Strength Sensor Test, you must first program feature F10 into the SX-V CPU and then enter Level 9. Remember, once the Protection Level is changed after a Signal Strength Sensor Test, feature F10 is automatically deleted from the CPU memory.

PHONE TEST

1. With the system in Level 0, enter Access Code + **8**
2. Display reads **8 PHONE TEST**
3. Between 1-2 minutes the display should read **0 DISARMED**

If the display shows 96 - FAILURE TO COMMUNICATE or 97 - NO PHONE LINE, refer to your SX-V Installation Manual (part no. 46-074) for troubleshooting the problem.

NOTE: After a Level 8 Phone Test, the Quick Arm feature is temporarily disabled. You must use the Access Code with your first command after completion of a Phone Test. This will allow the Quick Arm feature to function normally.

OPERATION NOTES**DISPLAY**

- The COMMAND button also acts as a dimmer control for the display. Press and hold the COMMAND button and the display will dim from 100% to 75%, 50%, 25% or blackout. Once you see the desired level, quickly release the COMMAND button.

Once a dim level is set, pressing any button will illuminate the display to full brightness. After 15 seconds of no touchpad activity, the display will return to the set dimmed level.

- If an alarm condition occurs while the display is dimmed, it will automatically return to the full brightness level and stay there until the user disarms the system and there is 15 seconds of no touchpad activity.
- The Entry Delay time and Level 9 Sensor Test will also force the display to full brightness. After disarming and no touchpad activity for 15 seconds, the display will return to the set dimmed level.

WALL MOUNT WIRELESS TOUCHPAD

(Walnut Enclosure) ITI Part #60-100

(Not Investigated by Underwriters Laboratories)

The Wireless Touchpad (WT) is used to give commands to the CPU. All arming, disarming and other signaling can be done with the WT.

When the CPU's program switch is ON, the WT becomes the installer's programming tool. (See section: PROGRAMMING)



The WT consists of two sections of touch sensitive pads, an ALARM section and a CONTROL section.

WIRELESS TOUCHPAD - ALARM SECTION

The ALARM section is used to manually trigger an alarm in Levels 0 through 8. The three alarms that can be triggered from the WT are POLICE, AUXILIARY (usually medical emergency), and FIRE. There are two buttons for each alarm and BOTH must be pressed simultaneously and held for one second to set off the alarm. This guards against accidental triggering of the alarms. The table below illustrates the CPU response when the two alarm buttons are pressed.

CPU ALARM RESPONSE

<u>BUTTON PRESSED</u>	<u>SENSOR NUMBER</u>	<u>LED DISPLAY</u>	<u>AUDIBLE RESPONSE</u>
FIRE + FIRE		80	Loud Steady tone siren
POLICE + POLICE		81	Loud Modulated Siren
AUXILIARY + AUXILIARY		82	Low-level beeping tone

When an alarm is activated from the Wireless Touchpad, a signal is also sent to the Central Monitoring Station.

WIRELESS TOUCHPAD - CONTROL SECTION

The CONTROL section is used to select the arming level. This section is made up of buttons 0 through 9, STATUS and BYPASS. To properly use the CONTROL section, it is necessary to know the 4-digit Access Code (combination). The system powers up with an Access Code of 1-2-3-4.

The 4-digit Access Code must be entered before any change in arming level. For example: To arm the system to protection level 1, enter the 4 digit Access Code, then immediately press the digit 1. A single "beep" will be heard and a "1" will be displayed on the CPU's protection level display window.

STATUS

The STATUS button serves two purposes during normal operations.



1. To request an audible indication of the system current protection level.
2. To activate the ALARM MEMORY and give a visual indication of any sensors that were in alarm during the previous arming period

The table that follows outlines the audible responses for each protection level when the STATUS button is pressed.

AUDIBLE STATUS RESPONSES**PROTECTION LEVEL**

0 - DISARM/CANCEL
 1 - SPECIAL
 2 - CHIME
 3 - EXTERIOR
 4 - AWAY
 5 - SILENT/AWAY
 6 - NIGHT
 7 - INSTANT/NIGHT
 8 - PHONE TEST
 9 - SENSOR TEST

AUDIBLE RESPONSE

One long beep
 One short beep
 Two short beeps
 Three short beeps
 Four short beeps
 Five short beeps
 One long and one short beep
 One long and two short beeps
 One long and three short beeps
 One long and four short beeps

ALARM MEMORY

The ALARM MEMORY is displayed at the CPU when the STATUS button is pressed. If an alarm occurred, the CPU will light the alarm LED and the number of any and all sensors that had been in alarm will be displayed. The ALARM MEMORY is available for review for six hours after the system is disarmed and then it automatically clears. Selecting Level 9 will also clear the ALARM MEMORY. There is no audible indication that an alarm occurred during the previous arming period.



The SX-V will not allow immediate selection of a new protection level unless all sensors active in that new level are closed or restored. Instead of arming to the new level, the system will generate two-tone "protest" beeps. The display will show which sensor(s) are open. The system can be "force armed" by using the BYPASS button.

INDIRECT BYPASSING

On a nice spring evening a customer could protect the house by arming to Level 6, and also leave his master bedroom window (for example, sensor 42) open. The BYPASS button is used to accomplish this. First, all doors and windows must be closed except the bedroom window, which is left open. Next, the system is armed to Level 6. When protest beeps are heard, immediately press the BYPASS button. This will cause the system to arm to Level 6 while bypassing the bedroom window, number 42.

This bypass procedure can be used to bypass more than one sensor at a time. It is recommended that the display always be checked to be sure the correct sensor or sensors have been bypassed

NOTE: The bypass procedure shall not be used in U.L. Listed installations.

AUTOMATIC BYPASSING

If the customer attempts to arm the system with a sensor or sensors in the non-restore condition, the system will generate protest beeps. Should the customer mistake the protest beeps for the exit delay beeps and leave the premises unsecured the SX-V will automatically arm to the protection level the customer attempted to select after 1-15 minutes. (The actual length of time will be the same value programmed into the CPU for Siren Time Out.) Any sensors which were causing the CPU to protest (ie: all open sensors) will automatically be bypassed. The CPU will report an "87 FORCE ARMED" to the Central Station.

DIRECT BYPASSING

Another way to BYPASS is called Direct Bypassing. To use direct bypassing, select a particular sensor number that you want bypassed. Then enter the 4 digit Access Code + BYPASS + the sensor number.

To bypass the same bedroom window (42) from the example above, arm the system to Level 6 (Access Code + 6). Next, enter the Access Code + BYPASS + 42. If properly bypassed, 42 will show in the sensor number window and the Bypass LED will be on. The Primary Access Code must be used when direct bypassing. The Temporary Access Code will not work for this feature. This will leave the CPU in protection Level 6 but bypass sensor number 42. All other sensors active in Level 6 will still be armed.

Using direct bypassing, the customer can bypass any sensor number (except sensors programmed for fire). Multiple sensors must be bypassed one at a time. With each direct bypassing command, the exit delay timer is reset to allow the user time to exit. With either method of sensor bypassing, keep in mind that changing the protection level clears the bypass. Thus, the customer must repeat the bypassing steps if they change protection levels and still want bypassed sensors. Below is a summary of the differences between direct and indirect bypassing.

INDIRECT BYPASSING

Primary, Low Level or Temporary Access Codes can be used to bypass sensors

Sensors to be bypassed must be open or activated. Sensors to be bypassed can be either open or closed.

Can only bypass those sensors which can be left windows).

Can bypass as many sensors as are open, all at at once.

DIRECT BYPASSING

Only the primary Access Code or High Level Access Codes can be used to direct bypass sensors.

Sensors to be bypassed can be

Any* sensor number can be open (doors and bypassed. *Not fire sensors.

Can only bypass one sensor number at a time.

INSTALLING THE WIRELESS TOUCHPAD

Most of the time the Touchpad will be left on its mounting bracket which can be permanently secured to a wall. It can also be lifted off its bracket for portability. Typical locations are near exterior doors and in or near the master bedroom.

INSTALLATION CONSIDERATIONS

DO

locate the Touchpad in a convenient location offering easy access for exit and enter control.

avoid metallic mounting surfaces such as foil wallpaper, steel frames, mirrored walls, etc.

test the Touchpad before you permanently mount it.

try to keep the Touchpad within 100 feet of the CPU.

Although the open air range of ITI sensors can be over 500 feet, the installation environment will influence this distance. The 100 foot distance recommendation is given as a starting guideline. In your actual installation, transmission range may be much greater.

DON'T

install Touchpad in areas with excessive metal or electrical wiring, such as furnace/utility rooms, etc.

attach mounting bracket with two sided tape.

locate Touchpad where it is likely to be exposed to moisture.

install the Touchpad in a location where the room temperature will exceed the Touchpad's operating limits 10° F to 140° F.

INSTALLATION

- 1 Secure the mounting bracket to the wall, narrow part up, hollow side towards you.

NOTE: The mounting bracket is not centered on the back of the Touchpad, it is off to one side. This must be taken into account when the Touchpad is to be centered between two objects.

- 2 A good height for the Touchpad is about 5 feet from the floor.
- 3 Mount securely, use molly bolts or plastic anchors if mounting on plaster.
- 4 Hang the Touchpad on the mounting bracket and be sure it is level.

HI TECH WIRELESS TOUCHPAD

ITI PART #60-365 (Not investigated by Underwriters Laboratories)

The SX-V HI TECH Wireless Touchpad offers an attractive addition to the ITI wireless touchpad line and includes the following features:

- Red LED flashes to indicate signal transmission.
- Panic buttons for Police, Fire and Auxiliary.
- Lithium battery life span of 3-5 years.
- Neutral color blends well with any decor.
- Mounting Plate included for wall mounting.

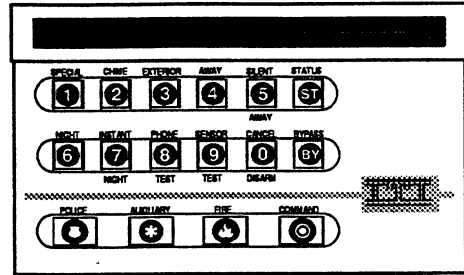

NOTE: The COMMAND button is not functional.

The mounting bracket also allows the user to remove the unit from the wall, if necessary.

PROGRAMMING

- 1 Remove the battery compartment cover at the top rear of the touchpad.
- 2 Connect the Handheld Programmer cable to the program plug located at the left end of the battery compartment. This plug is polarized so the cable will only fit one way.
- 3 Press the HOUSE CODE button on the programmer, then enter the 3 digit House Code of the CPU.
- 4 Press ENTER. Programmer display should read **done**.
- 5 Replace the battery compartment cover.

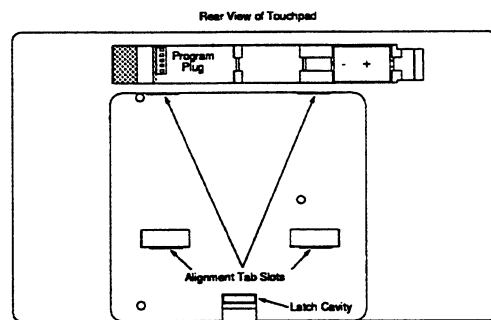

TESTING

Test the touchpad from several areas on the premises using the steps described below. Note any areas which exhibit intermittent or inconsistent results. Inform your customers that those areas should be avoided when using the touchpad.

The LED at the upper right corner of the touchpad will flash twice when buttons 0-9 or the STATUS and BYPASS buttons are pressed to confirm signal transmission. The LED will flash 12 times when the Police, Fire or Auxiliary panics are pressed and held.

- 1 Arm the system to all protection levels.
- 2 Press STATUS to check the current protection level.
- 3 Bypass sensors using Direct and Indirect methods (refer to your SX-V Installation manual).
- 4 Press and hold each panic button until you hear 6 rapid beeps in succession. Only then will the CPU go into alarm.

MOUNTING

IMPORTANT! Before mounting, place the touchpad against the wall at the desired location. Follow the testing procedure on the front side of this document to ensure consistent operation from that location.

- 1 Place the mounting bracket at the desired location in the position shown at right.
- 2 Mark the 2 mounting screw locations.
- 3 Use appropriate anchors and screws to secure the mounting plate to the wall.
- 4 Using the diagram below as a guide, position the touchpad slightly above the top alignment tabs of the mounting bracket. Slide the touchpad down until you hear a faint "click", indicating the latching/release tab has secured the unit to the mounting plate.

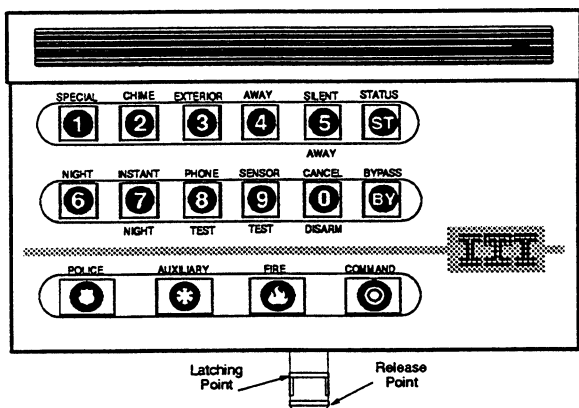
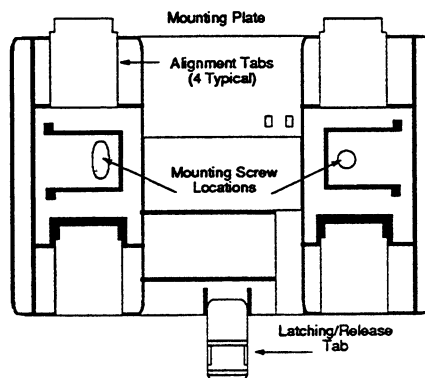

TOUCHPAD REMOVAL

To remove the touchpad from the wall, use a small blade screwdriver. Push on the latching/release tab with the screwdriver (see diagram below), then slide the touchpad up.

To re-install the touchpad, follow step #4 above

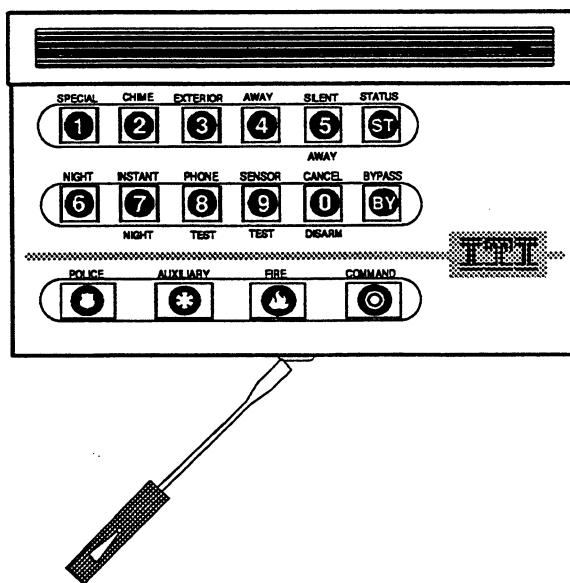

HAND HELD WIRELESS TOUCHPAD (HHWT)

ITI Part #60-101

The Hand Held Wireless Touchpad is housed in a pocket size plastic case and functions in the same way as the model in the walnut enclosure. The Hand Held Wireless Touchpad is light weight and portable. It is used to arm and disarm the CPU and can also be used to perform some programming functions. The Status and Bypass buttons work the same as on the walnut Wireless Touchpad.

Estimated battery life is 5 to 8 years.

ALARM KEYS

The Alarm Keys are used to manually trigger an alarm. The two alarms that can be triggered from the HHWT are POLICE and AUXILIARY (usually medical emergency). There are symbol buttons (a shield for POLICE and an asterisk for AUXILIARY) and a button labeled "ALARM." BOTH the symbol and the ALARM button must be pressed simultaneously and held for one second to set off the alarm. This guards against accidental triggering of the alarms.

NOTE: The alarm keys are not active in U.L. listed systems.

Try to keep the Touchpad within 100 feet of the CPU.

Although the open air range of ITI sensors can be over 500 feet, the installation environment will influence this distance. The 100 foot distance recommendation is given as a starting guideline. In your actual installation, transmission range may be much greater.

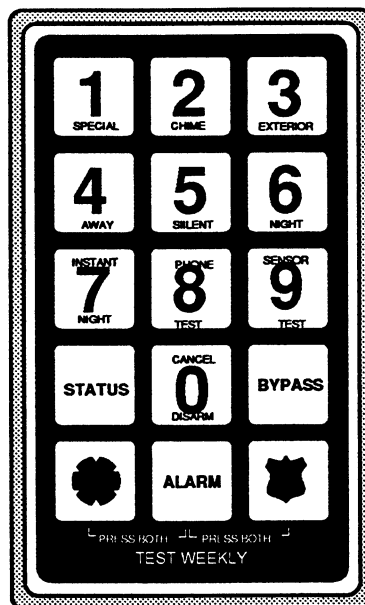

HARDWIRE TOUCHPAD AND DISPLAY

ITI Part #60-193

The Hardwire Touchpad and Display is a supervised component operating on the Hardwire Buss that offers you four products in one unit. The **Display** duplicates the visual indications on the CPU. It also contains an **Annunciator** capable of making both low volume status sounds and full volume alarm sounds. Two terminals allow for a N/O or N/C hardwired **Burglary Loop**. Finally, it allows you to arm, disarm and also program the system with its built-in Touchpad.

NOTE: The Hardwire Touchpad described is compatible **ONLY** with SX-V CPU's with "board revisions" of 'H' or later and software dated 11-30-87 or later.

PRELIMINARY CONSIDERATIONS

DO

locate the Hardwire Touchpad and Display in a convenient location offering easy access for exit and entry control. A good height for the Hardwire Touchpad is about 5 feet from the floor.

consider the total current draw of all hardwired devices on the buss.

DON'T

locate Hardwire Touchpad where it is likely to be exposed to moisture.

install the Hardwire Touchpad in a location where the room temperature will exceed the Hardwire Touchpad's operating limits 10° to 120° F.

NOTE: It is recommended that the touchpad is mounted so that the display not be visible from outside of the protected area.

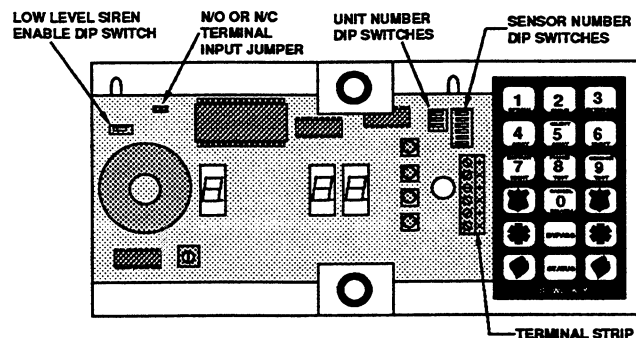

ANNUNCIATOR SOUNDS OPTIONS

The hardwire Touchpad has DIP switch that allows the choice of either High Level Alarm sounds only or all Alarm and Status sounds.

High Level Alarms Only - With the DIP switch "OFF", High Level Alarm sounds only (such as Police and Fire) no low level alarms or status beeps. Used in areas where Status sound could be disruptive such as near children's bedrooms.

NOTE: If a hardwire interior siren is not used or a hardwire interior siren is used but location F11 is "set", then the siren sound option switch shall be "on".

UNIT NUMBER DESIGNATION

Each device on the hardwire buss must be assigned a unit number from 0 to 7. The unit number uniquely identifies each device on the buss. If one of the devices fails, the CPU reports a "77 Supervisory" signal. The Hardwire Touchpad and Display includes a set of three DIP switches which set the unit number. Set these DIP switches prior to applying power to the Hardwire Touchpad. Use the table below to set the unit number DIP switches.

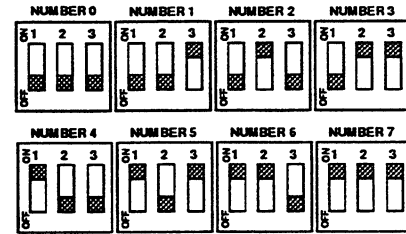

INSTALLATION INSTRUCTIONS

1 Set unit number DIP switches.

2 Make all connections with the power off. Each unit requires a 4 conductor wire connection (shielded wire is preferred). For lengths from 1 foot to 50 feet, use 22 gauge; for lengths over 50 feet, use 18 gauge or greater stranded, twisted cable. The maximum wire run resistance should be no more than 200 ohms. The maximum current draw is 100 MA per Hardwire Touchpad. When determining how many Hardwire Touchpad's can be powered directly by the CPU, keep in mind that the total current available to power all devices hardwired to the CPU is 200 mA (normal supervisory condition).

3 Mount securely, use molly bolts or plastic anchors if mounting on plaster.

4 Power up the CPU and place the programming switch in the program position, then press the STATUS button on the Hardwire Touchpad.

NOTE: Sensor number 77 must be programmed into the CPU in order for the hardwire buss to be supervised. The CPU will "learn" the unit numbers of each device on the hardwire buss. If you wish to change a unit number, you must remove 77, make the change, then reinitialize 77.

5 Return the program switch to the operate mode.

Programming the C.P.U. House Code

1 Turn the C.P.U. Program Switch to "ON".

2 Press the "BYPASS" key on the touchpad.

3 Press and hold both "FIRE" keys until you hear 6 beeps from the touchpad.

4 Enter the desired 3 digit House Code.

5 Press and hold the "Fast Forward" button on the SX-V C.P.U.

6 Release the Fast Forward button when the sensor number display begins to scroll.

7 Verify House Code programming by watching the C.P.U. or touchpad display. The letter "H" will appear in the protection level window, indicating that the next 3 digits shown in the display windows will be the house code of the C.P.U.

HARDWIRE TOUCHPAD AND DISPLAY WIRING DIAGRAM

CAUTION: Be careful not to bend the LED leads when making wiring connections to the terminals.

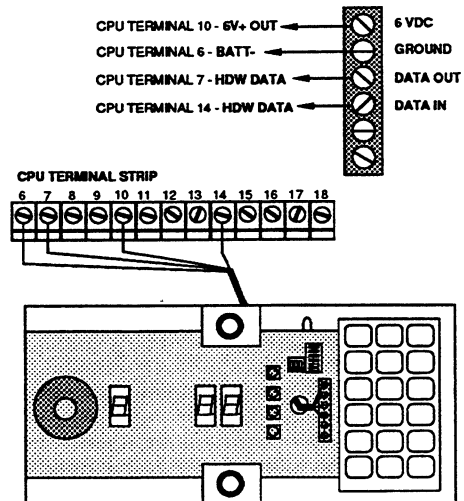

SETTING THE SENSOR NUMBER AND HARDWIRED SWITCH

The Hardwire Touchpad and Display includes two additional terminals (the bottom two) to attach a hardwire burglary loop. The device connected to the loop requires a minimum 3 second lockout and a 1 second open and close time. Use 20 gauge stranded twisted pair wires and do not exceed 50 feet in length.

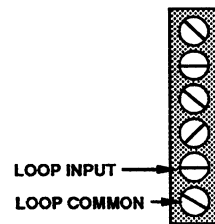

A group of six DIP switches set the sensor number. The first three DIP switches (1, 2 and 3) are used to set the first or most significant digit of the sensor number and the last three (4, 5 and 6) are used to set the second or least significant digit. For example, if a switch were hardwired to an exterior door and is to be sensor 37, the first three DIP switches will be set to the 3 and the last three DIP switches set to 7. The table of switch settings given for the unit number can be used to set each group of three DIP switches.

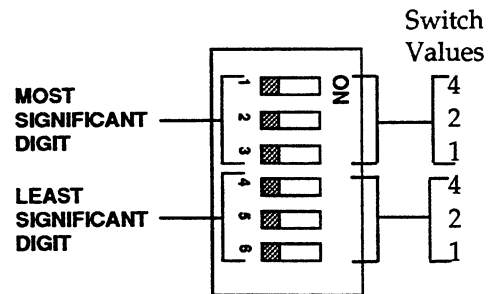

The sensor number chosen will operate with the same standard default sensor and group characteristics as a wireless sensor. See the sensors chart. These characteristics can only be changed through programming from a central station.

IMPORTANT: If the terminals are not being used, all DIP switches must be set to the OFF position.

The configuration of the hardwire switch, whether normally open (close initiates alarm) or normally closed (open initiates alarm), is set by the jumper in the upper left hand corner of the Hardwire Touchpad and Display. If the loop is to be normally closed, keep the jumper in place. If the loop is normally open, remove the jumper.



NOTE: The normally closed configuration shall only be used in U.L. listed applications.

SENSORS

NOTE: Most all sensors you will program with the HandHeld programmer for the SX-V system. These sensors are polarity sensitive when connecting the programming cable from the HandHeld programmer. Refer to the diagram at right for correct orientation of connector on sensor.

DOOR/WINDOW SENSOR (DWS)

ITI Part #60-135 (white), ITI Part #60-151 (brown)

These sensors are designed to be installed on doors, windows, gun cabinets, or anything else that opens and closes. Each contains 2 built-in magnetic reed switches and is designed to go into alarm by moving the supplied magnet away from one of the sensor's reed switches. The sensor offers screw terminals that will accept normally open or normally closed hardware devices (switches, carpet mats, etc.) Any external hardwired devices connected to this sensor must be U.L. listed.

Note: When a sensor is located at its intended position and is not heard by the receiver, it may be necessary to rotate the sensor 90°.

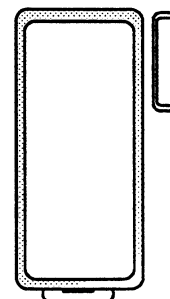

A Door/Window Sensor will transmit signals during normal operation. When a door is opened, a "VIOLATION" signal is sent to the CPU. When the door is closed a "RESTORE" signal is transmitted. *These signals are sent whether the system is armed or not.* If an attempt is made to arm the system to a level in which the sensor is active and that sensor is in a violated state (door open, for example), the CPU will "protest" by emitting a series of continuous beeps and refuse to arm to the desired level. The number of the violated sensor will also be displayed on the CPU's LED display. The system can be armed when all of the sensors used at a particular protection level are in the "RESTORE" condition, or, if the user deliberately "BYPASSES" one or more sensors.

BATTERY POWER — The Door/Window Sensor is powered by a 3.5 volt lithium battery. The battery is not monitored. Under normal circumstances, the battery should last 5 to 8 years. A supervisory indication would be detected and reported by the CPU if the battery failed.

TEMPERATURE RANGE — 10° F to 120° F

TAMPER SWITCH — Door/Window Sensors contain a built-in tamper switch. Removing the sensor cover causes the sensor to transmit a "TAMPER" signal to the CPU. If the CPU is armed to a protection level in which the tampered sensor is active, an alarm will occur. If the tampered sensor is not active in that arming level, the CPU will not go into immediate alarm, but will remember the TAMPER signal and "PROTEST" (as if the sensor had been left open) the next time an attempt is made to arm the system. Replacing the sensor cover closes the tamper switch but does not send a signal to the CPU indicating that the switch has been closed. The CPU will still "PROTEST" until a "RESTORE" signal is heard from the sensor. This can be accomplished by opening, then closing the protected door or window.

NOTE: The tamper feature cannot be disabled.

IMPORTANT — When working on Door/Window Sensors, be sure to select a protection level in which the sensor, whose cover you are removing, is disarmed before opening sensors. For 24 hour sensors or if F15 is active, this will mean selecting protection level 9.

SUPERVISORY INDICATIONS

Every 69 minutes sensors send a supervisory signal to the CPU. If no signals have been heard from a particular sensor after 12 hours, the number of the problem sensor is displayed and the "SUPERVISORY" LED is lit. The problem sensor will be reported to the Central Station.

INSTALLATION CONSIDERATIONS

DO

mount magnet on one door, sensor on the other for double door installation.

mount sensors with screws, not two-sided tape.

try to keep all transmitters within 100 feet of the CPU.

Although the open air range of ITI transmitters can be over 500 feet, the installation environment will influence this distance. The 100 foot distance recommendation is given as a starting guideline. In your actual installation, transmission range may be much greater.

avoid areas with excessive metal or electrical wiring, such as furnace/utility rooms.

avoid locating transmitters where they are likely to be exposed to moisture.

install the sensor in a location where the temperature will not exceed the sensors operating limits of 10° F to 120° F.

DON'T

mount within 5 inches of the floor on a door to avoid damage.

forget to use spacers when mounting sensors or magnets on any metallic surfaces such as metal doors or foil wallpaper.

INSTALLATION

- 1 Remove the sensor cover by pressing on the cover end to release the tab on the cover from the slot in the sensor base.

CAUTION!!! It is important for you to be free of all static electricity when handling transmitters. Touch something metal, before handling the transmitter circuit board. Handle only by the edges. Never set the circuit board on any metallic surface.

- 2 Carefully remove the circuit board by pulling back on the tab and lifting the battery holder; or gently flex the plastic sensor base to release the circuit board.

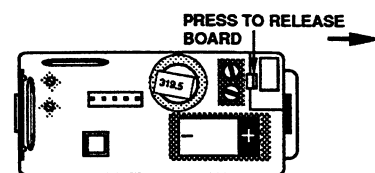

- 3 Two screw holes are provided, one is enlarged to allow for sensor alignment.
NOTE: The sensor base has markings which indicate the position of the reed switches when the circuit board is reinstalled. Use the markings to aid in your alignment.
- 4 Use #6 flathead screws when mounting the sensor. Two optional small holes are provided to allow for mounting with 18 gauge wire nails. Spacers are available if you will be mounting on a metallic surface or to aid in height alignment.

Door/Window Sensor Spacers (white) Part #60-189, (brown) Part #60-191
 Magnet Spacers (white) Part #60-188, (brown) Part #60-190

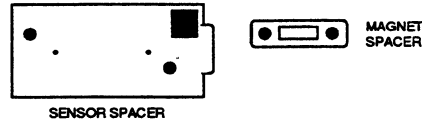

- 5 Mount magnet base within 3/8" of the sensor's base, centered on the notch or tab. Use two #6 x 1/2" flathead screws or #18 x 1/2" wire nails. A brad driver works well if using nails.
- 6 Be sure magnet won't interfere with door or window opening.
- 7 Be sure to use a spacer if you must mount the magnet on a metal surface.
- 8 Do not use two sided tape to mount magnet.
- 9 Replace the circuit board.

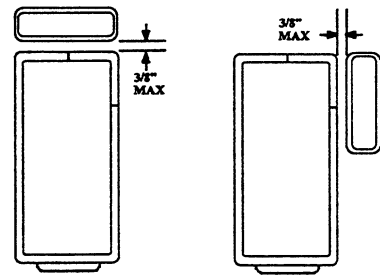

Note: After determining which reed switch you will be using in the installation, remove the other reed switch by clipping leads as close to the board as possible.

- 10 Program the Sensor.
 Typical sensor numbers for DWS include 30 - 37, 40 - 47, 50 - 57 and 70 - 76.
 See PROGRAMMING Section
- 11 Replace the sensor cover.

INTERFACING REMOTE DEVICES TO A DOOR/WINDOW SENSOR

The Door/Window Sensor can be connected to either Normally Open (closes on alarm) or Normally Closed (open on alarm) devices. The configuration of the sensor is a programmable option selected using the Programmer. See Programming section.

NOTE: The normally closed configuration shall only be used in U.L. listed installations.

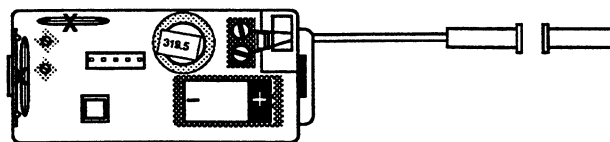

For high-security applications, always remove both reed switches when interfacing a remote device to the terminals of the DWS .

Multiple NORMALLY CLOSED devices would be wired in SERIES all in the same line. Multiple NORMALLY OPEN devices would be wired in PARALLEL all to the same two screw terminals.

Note: Use recognized limited energy cable to all initiating, indicating and supplementary devices.

INTERFACING CONSIDERATIONS

DO

make sure the device connected to the sensor is a hermetically sealed type, such as a sealed reed switch. DON'T use mechanical switches connected to a DWS.

make sure the device supplies a minimum 100 millisecond open or closure on alarm. This is important! DON'T attempt to connect fast pulse devices such as Window Bugs to a DWS.

use stranded wire, not solid core wire. DON'T exceed 25 feet of 22AWG (minimum) wire in any wire run if using twisted wire.

DON'T

exceed 6 feet of wire in any wire run if using untwisted wire.

use the Sensor's built-in reed switch if connecting a remote device to the sensor. Remove the reed switches not being used.

connect more than 5 switches to a DWS. Fewer than 5 is preferred.

connect more than 1 alarm screen to a DWS.

run wires within 18" of electrical wiring. Never run parallel to electrical wires, cross them at a 90 degree angle.

RECESSED MOUNT DOOR SENSOR

ITI Part #60-239-11 (Not investigated by Underwriters Laboratories)

These wireless sensors are primarily designed to be installed on doors, but may also be suitable for some windows. When installed, this sensor is virtually invisible. Recessed Mount Door Sensors are stand-alone devices - they may not be connected to other sensors.

Each sensor contains a built-in magnetic reed switch and will transmit an "open" signal when the magnet is moved away from the reed switch. The Recessed Mount Door Sensor is compatible with the SX-V or CareTaker. A magnet is included.

BATTERY: 3.5 volt lithium battery. Life expectancy: 5-8 years.

SUPERVISION: Sends supervisory signal to the CPU every 69 minutes.

TEMPERATURE: 10-140 degree operating range.

HUMIDITY: Up to 95% non-condensing.

IMPORTANT: When planning to install a Recessed Mount Door Sensor, be sure to thoroughly test the sensor for proper radio range prior to drilling 7/8" hole!

CAUTION!!! It is important for you to be free of all static electricity when handling transmitters. Touch something metal before handling the transmitter circuit board. Handle it only by the edges. Never set the circuit board on any metallic surface.

INSTALLATION

- 1 Remove the sensor cover by inserting the tip of a small screwdriver or file into the notch of the cap and prying it from the transmitter tube.
- 2 Carefully slide the circuit board from the transmitter tube.
- 3 Program the sensor using the programming cord. Remember to discharge static before connecting the cord. Observe polarity (see diagram).
- 4 Place circuit board back inside the transmitter tube and replace the cap. Make sure the battery end slides in first so the reed switch is closest to the transmitter cap.

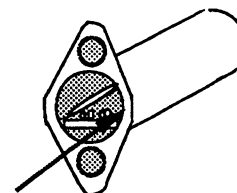

Arrow points to only spot where you grab P.C. board with SMALL needlenose to gently remove board

POLARITY MUST BE OBSERVED

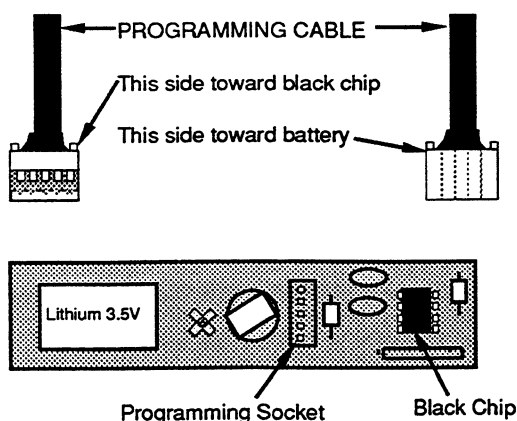

IMPORTANT NOTICE

The programming socket on this transmitter is a new design which is not polarized like the earlier plug. The drawing on the reverse side shows the proper polarity when connecting the programming cable. Connecting the cable backwards will not harm the transmitter or programmer but will fail to program the sensor.

- The ITI Programmer will display "FAIL" if the cord is backwards.
- If you program directly from an SX-V CPU, no bouncing balls will be shown if the cord is backwards.
- If programming from a CareTaker the voice will sound "Sensor Program Failure" if incorrect.

CAUTIONS

Doors - Many doors are not centered in the door frame. Make sure you drill far enough toward the center to avoid drilling through interior walls or exterior siding. Drilling into the top of the door frame is the best location.

Windows - Many windows are set towards the outside of the building. Make sure the hole will not break through the outside of the siding. Drilling into the top of the window frame is the best location.

Metal - Due to R.F. constraints recessed mounting of the sensor into metal is not recommended. It would be difficult to test the sensor for proper range prior to drilling the hole.

MOUNT THE TRANSMITTER

- 1 Using a 7/8" spade or paddle bit, drill a hole to the minimum depth of 4 3/4" in either the door or the door frame. (or window/window frame if mounting as a window sensor.) * Frame mounting is preferred, due to less possibility of shock damage.
- 2 Slide the transmitter tube into the hole. The lip of the tube should fit snugly against the surface of the wall.
- 3 Test the transmitter to be sure it is operating correctly. Once it is working, use the screws and screw-holes provided to secure the transmitter in place. (you must use the proper screws).



MOUNTING THE MAGNET

- 1 Drill a 1/2" diameter hole for mounting the magnet in wood. The hole should be 1 1/2" deep and centered on the transmitter hole opposite.
- 2 Place magnet in hole, it should fit tight. If not, secure with adhesive.
- 3 Be sure magnet won't interfere with door or window opening. Test the transmitter to be sure it is working properly.

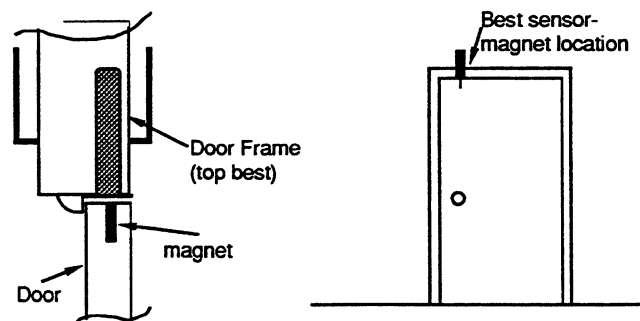

SOUND SENSOR (WIRELESS)

ITI Part #60-249 (Not investigated by Underwriters Laboratories)

The ITI wireless RF Sound Sensor consists of an audio discriminator and a special ITI transmitter built into the same unit. The Sound Sensor is designed to respond only to the frequencies generated by breaking glass. The sensor will detect breaking glass of 1/16" to 1/4" thickness, as well as tempered glass. The unit is powered by a 3.5 VDC lithium battery which should last about 5 years. The Wireless Sound Sensor (#60-249) works with any SX-V and the CareTaker if a radio receiver is installed. (For hardwire applications, use the Hardwire Sound Sensor, Part #60-139).

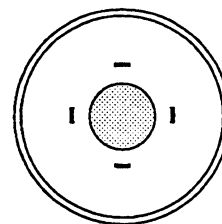

INSTALLATION CONSIDERATIONS

DO

- use common sense when deciding whether or not an environment is suitable. With a Sound Sensor you must avoid sources of loud noises, such as those listed below:
 - Avoid china or glass stores.
 - Avoid noisy machinery and air compressors.
 - Avoid mechanical rooms and furnace rooms.
 - Avoid steam heat radiators that can clang or hiss.
- If possible, avoid putting a Sound Sensor in the same room as an Interior Siren. If you must, keep them 10" away from each other.
- Some electronic telephones and electronic door chimes have ringers that can cause problems.
- If you are in doubt whether or not an area is quiet enough for a Sound Sensor, place the system in the Sensor Test Level and turn on everything that makes noise. If the Sound Sensor does not activate, the installation is probably acceptable.
- be conservative in determining how much area each Sound Sensor will protect. If in doubt, place two Sound Sensors in the area. The Sound Sensor will cover approximately 900 square feet if it is centrally located from all glass to be protected.
- mount the Sound Sensor on a solid surface.

DON'T

- attempt to change the sensitivity adjustment of the sensor. It has been factory set for optimal performance.

INSTALLATION INSTRUCTIONS

- 1 A Sound Sensor should be installed on a ceiling or wall. It should be mounted no more than 15 feet from the glass to be protected. If the installation is to be in an area with multiple windows to protect, the sensor should be mounted at an equal distance from all glass and in a direct line-of-sight to the glass it is protecting.

- 2 Remove the mounting plate from the Sound Sensor by rotating it counter-clockwise.
- 3 Attach the mounting plate to the wall or ceiling using the appropriate screws and anchors.
- 4 Program the sensor, typically Sensor Number 60-67 for an SX-V and Group 09 for a CareTaker. Program sensor type 3 for both systems. To program, use the SX-V Hand Held Programmer. Enter the House Code, then the Sensor Number and the Sensor Type as explained in the Installation manuals for the SX-V and the CareTaker. When you press number 3 for the sensor type, the LED on the Motion Lockout Timer button will light.

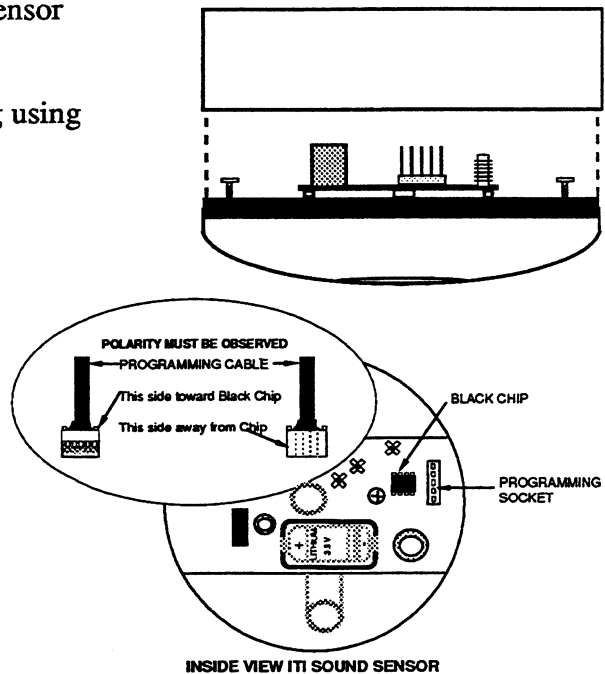

Press the Motion Lockout Timer button to deactivate it. Press enter. If "Fail" is displayed, check your programming and try again. If "Done" is displayed, you may move on.

- 5 Re-attach the Sound Sensor to the mounting plate.

TESTING THE SOUND SENSOR

The Sound Sensor has been tested and adjusted at the factory. Perform the following test to verify the proper functioning of the sensor's circuitry and transmitter at the installation location:

- 1a For an SX-V, be sure the CPU is programmed with Optional Feature F10. Then arm the CPU to Level 9, SENSOR TEST.
- 1b For a CareTaker, enter the Service Test Mode by keying * SERV # 9.
- 2 Use the IEI - 515 Audio Glassbreak Detector, available from IEI and most distributors, to verify the Sound Sensor operation. While holding the tester at the glass to be protected, point directly at the sensor and press the test button.
- 3 Note the number of beeps sounded by the annunciators as the data rounds are received by the CPU. (7-8 are acceptable, 6 are marginal, less than 6 unacceptable and sensor should be relocated.)

SMOKE SENSOR

ITI Part #60-106 (Canada Part #60-363)

ITI Part #60-521 (Canada Part #60-521-319.5-CN) see appendix A.

The Smoke Sensor is a Photo-Electric type that contains its own Alarm Horn and Low Battery Annunciator. It has an output that will trip a special transmitter already built into the detector. The built-in alarm horn will sound as long as smoke remains in the Smoke Sensor. It is powered by two 9 Volt Alkaline batteries. Both of the 9 volt batteries are monitored. The Smoke Sensor's own low battery annunciator will make a short "beep" sound every minute until the batteries are replaced. *THIS SMOKE SENSOR REQUIRES EVEREADY ALKALINE BATTERIES #366. DO NOT USE SUBSTITUTES. The Canadian ESL 361C (60-363) requires the Duracell Alkaline Battery #366.*

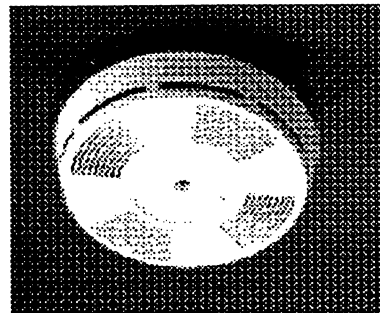

Refer to the Owners Manual included with each Smoke Sensor for detailed information. Also, be sure to give the Smoke Sensor's Owners Manual to the purchaser of the system after the installation is complete. Additional information on Household Fire Warning is available at nominal cost from: The National Fire Protection Association, Battery Mark Park, Quincy, MA 02269. Request NFPA Standard 74.

SUPERVISORY INDICATIONS

Every 69 minutes sensors send a supervisory signal to the CPU. If no signals have been heard from a particular sensor after 12 hours, the number of the problem sensor is displayed and the "SUPERVISORY" LED is lit. The problem sensor will be reported to the Central Station.

INSTALLATION CONSIDERATIONS

While it is not possible to get too specific about Smoke Sensor location (since each residence has different design requirements), there are some guidelines that can be followed. Refer to the sensor's Owners Manual for detailed information on sensor location. Some additional hints appear on the next page:

DO

- determine the best locations for each Smoke Sensor so as to optimize early detection, and maintain accessible escape routes out of the building.
- locate a Smoke Sensor at the bottom of the basement stairwell(s). For other levels, it is usually best to locate Smoke Sensors at the top of the stairwell.
- locate a Smoke Sensor in any hallway servicing bedrooms. For maximum protection, place a Smoke Sensor inside each bedroom, especially smoker's bedrooms or bedrooms where electric blankets or other electrical devices are used.
- mount sensors on ceilings whenever possible. Make sure that the sensor is no closer than 4 inches to any wall. For wall mounting, make sure that the nearest edge of the detector is at least 4" and no more than 6" from the ceiling.
- avoid mounting sensors on any slanted surface.

DO

- try to keep the Smoke Sensor within 100 feet of the CPU.
Although the open air range of ITI transmitters can be over 500 feet, the installation environment will influence this distance. The 100 foot distance recommendation is given as a starting guideline. In your actual installation, transmission range may be much greater.
- check for areas of the installation which may inhibit the Smoke Sensors radio signals from reaching the CPU. This would include areas with excessive metallic surfaces or electrical wiring.

MOUNTING THE SMOKE SENSOR

- 1 Remove the sensor's mounting bracket to screw onto mounting surface.
- 2 Mount directly onto wood surfaces using 1 1/2" wood screws. If mounting onto plaster or dry wall use molly bolts or appropriate plaster anchors.
- 3 If you have not already done so, program the sensor, typically 20 to 27 (see PROGRAMMING Section).
- 4 Re-attach sensor onto the mounting bracket.

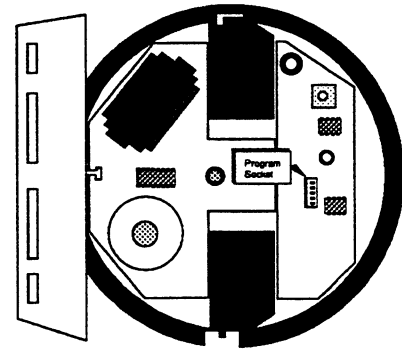

NOTE: Ceiling mounted smoke detectors should be located in the center of the room or hall, or not less than 4 inches from any wall. When the detector is mounted on a wall, the top of the detector should be 4 to 12 inches from the ceiling

NOTE: Do not install smoke detectors where normal ambient temperatures are above 100 F or below 40 F. Also do not locate detectors in front of AC/Heat registers or other locations where normal air circulation will keep smoke from entering the detector.

NOTE: Additional information on household fire warning is available at nominal cost from: The National Fire Protection Association, Batterymarch Park, Quincy, MA 02269. Request Standard No. NFPA74.

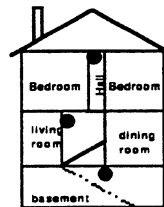

A smoke detector should be located on each level.

Required smoke detector

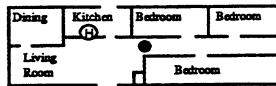

Smoke detectors should be located between the sleeping area and the rest of the family living unit.

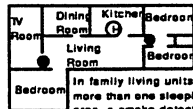

In family living units with more than one sleeping area, a smoke detector should be located at each area.

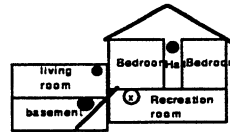

Indicates smoke detector is optical door is not provided between call and recreation rooms.

Heat Detector

TESTING THE SMOKE SENSOR

The following procedure can be used for testing. It can be done now or with the final testing of the entire system. *If the phone jack is plugged in, the Central Station will receive the alarm. The Central Station must be informed before testing begins.*

- 1 Verify that the CPU is programmed with the sensor number(s) of the Smoke Sensor(s) being tested. If not, program the CPU as described in the Programming Section.
- 2 Arm the CPU to protection Level 9 (SENSOR TEST). The sensor numbers of the Smoke Sensors being tested should scroll in the CPU display window.
- 3 Press and hold the test button on the Smoke Sensor for **20 to 30 seconds** until the alarm horn sounds and the red light glows steadily. The ESL366 horn sounds instantly, the ESL361C (Canada) has a delay before sounding.

- 4 Check the scrolling sensor numbers on the CPU. The sensor's number should no longer be displayed.
- 5 It is recommended that the Smoke Sensor be tested as part of the SX-V system by disarming to Level 0 and pressing the test buttons on the sensors. Sirens should sound with a steady loud tone. The Smoke Sensor's built-in alarm will stop a few seconds after the test button is released. Rearm to level 0 to stop the CPU siren.

NOTE: The alarm system sirens and the Smoke Sensor's built-in siren will **BOTH** sound when smoke is detected. The CPU alarm is cancelled from the Touchpad (Access Code + 0) and the sensor's alarm is cancelled by clearing the smoke from the detector.

RATE-OF-RISE SENSOR

ITI Part #60-137

(Not investigation by Underwriters Laboratories Inc.)

(Not Listed by California State Fire Marshal)

The ITI Rate-of-Rise Sensor is a detector and transmitter in one unit designed to protect spaces of up to 2500 square feet. Like other thermostats, these will initiate an alarm when a fixed temperature has been reached, typically 135°F. In addition, since many fires grow rapidly in intensity, resulting in rapidly rising temperatures, these sensors are designed to sense the rate which the temperature is rising. They will, therefore, respond to an increase in temperature which is 15°F per minute or greater.

BATTERY POWER

The Rate-of-Rise Sensor is powered by a nine volt alkaline battery. Under normal conditions, the battery will last 12 to 18 months or more. If the battery begins to get low, the CPU will display and report the sensor number of the Rate-of-Rise with the low battery.

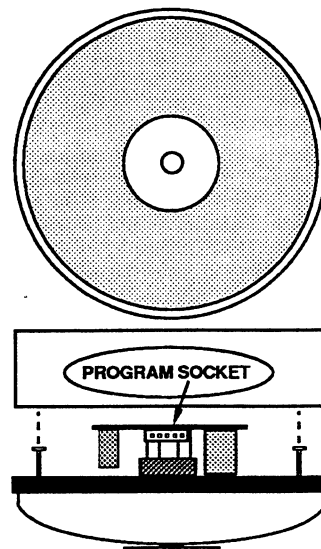

INSTALLATION

The ITI Rate-of-Rise Sensor is a normally open device which closes on alarm. The sensor can be mounted in areas such as; garages, attics and kitchens. Ceiling mounting near the center of the area to be protected is recommended.

NOTE: Do not mount Rate-of-Rise too close to something that changes temperature fast, such as above an oven or near a heat duct, furnace or boiler.

- 1 Remove the sensor base and secure to the ceiling. Use screws if securing to wood or anchors if securing to plaster or wallboard.
- 2 If you have not already done so, program the sensor. Choose a sensor number for the heat or fire group, typically 20 - 27.
- 3 Reattach the sensor to the mounting bracket.

TESTING

Periodic testing of the Rate-of-Rise Sensor is recommended, but should only be done by an installer. Heat from a 1000 watt portable hair dryer is suggested. Place the hair dryer about 12 to 18 inches **from the side** of the sensor. The Rate-of-Rise should trip within 7 to 10 seconds.

NOTE: Rate-of-Rise Sensors should not be tested with a flame since this will necessitate replacing the unit. When tripped by rapid temperature increases, these sensors will reset themselves if the fixed setting is not reached.

Do not use with 190° fixed Rate-Of-Rise sensor. Transmitter will fail before temperature reaches 190°.

FIRE PULL STATION

ITI Part # 60-287 (Not investigated by Underwriters Laboratories)
(Not Listed by California State Fire Marshal)

The ITI Fire Pull Station is a manually activated unit connected to an ITI Door/Window Sensor. It can be wall mounted almost anywhere in residential or small commercial installations to summon fire authorities. The transmitter is activated by pulling down the clear shield and pressing in the center of the white circles. It is reset by inserting the plastic key into the notch at the top. The Fire Pull Station transmitter is powered by a lithium battery which under normal conditions should last 5 to 8 years. The battery is not monitored. A supervisory condition would be reported by the CPU if the battery failed.

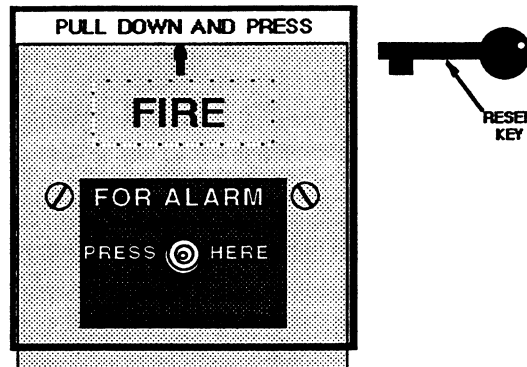

INSTALLATION

- 1 Remove the base and secure to the wall using the top two mounting holes. Use mounting screws if securing to wood, or anchors if securing to plaster or wallboard.
- 2 If you have not already done so, program the door/window sensor. Choose a sensor number for the heat or fire group:
- 3 Remember to observe polarity - the open side of the programming cable faces the black chip. It's a good idea to set the CPU to Level 9 and trip the Fire Pull Station at this time to verify programming and operation.
- 4 Replace the cover on the transmitter and place it in the lower part of the mounted base. The cover must always be in place for proper operation.
- 5 With the clear plastic cover open, place the bottom edge of the Fire Pull into the base. Then press the top into place. You will feel the plastic pins snap into place.
- 6 Install and tighten the two cover screws.

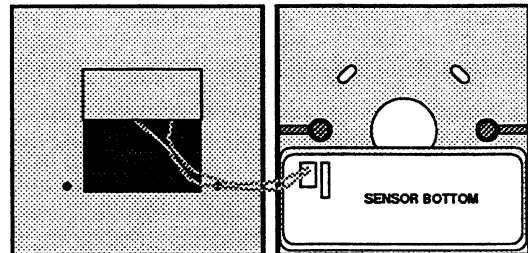

PROGRAMMING

Program the sensor:

Sensor Number 20-27
Sensor Type 9
Normally Open Sensor

You must also use the CS-4000 to re-group the selected sensor to Group 02, Letter Code L.

Because a Door/Window Sensor is being used in the Fire Group, the sensor must be re-grouped to letter code "L" so the CPU will not be looking for a low battery condition. (Lithium battery powered sensors can't report low battery.)

If you don't re-group to letter code "L" the CPU will display "Trouble" instead of tamper (alarm) if the sensor is opened.

TESTING

- 1 Place the CPU into Level 9 Sensor Test. (Use F-10 for an SX-V or Dealer Sensor Test for CareTaker to hear the 16 rounds)
- 2 Press firmly in the center of the white circles on the Fire Pull Station. The switch will snap and a yellow bar will appear verifying that the switch has been tripped.
- 3 Reset the Fire Pull by inserting the plastic key into the notch at the top of the station and turn to the right.

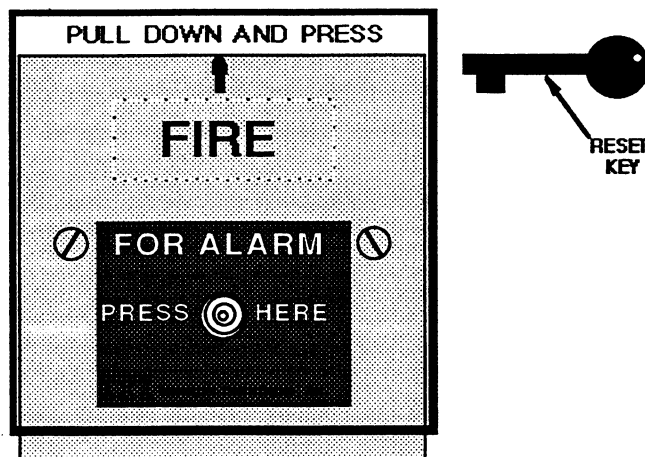

PASSIVE INFRARED MOTION SENSOR

ITI Part #60-364

(Not investigated by Underwriters Laboratories)

A Passive Infrared (PIR) Sensor is designed to detect movement in the interior of an enclosed structure. The PIR Sensor adapts to the environment in which it is placed, and continually gathers information about that area. Any change in this stable environment caused by an object which emits a different degree of infrared heat energy is sensed and an alarm is generated.

When a PIR detects thermal movement, a "VIOLATION" signal is sent to the CPU. These signals are sent whether the CPU is armed or disarmed. A properly programmed PIR cannot prevent the system from arming.

PIR sensors are SUPERVISED, i.e. they send a check in signal to the CPU every 69 minutes just like the DWS.

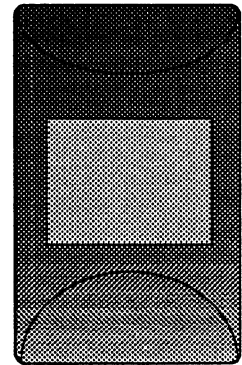

BATTERY POWER: The PIR uses a 3.5 VDC Lithium battery. Under normal conditions this battery will last 3 Years.

TEMPERATURE RANGE: 10°F TO 120°F

PULSE COUNT: A pulse count mode is provided on the transmitter circuit board. Refer to the DS923 Installations for more detail.

TEST FEATURES: A fast-reset LED walk light is activated by pressing the Walk Test Activation switch. When pressed the PIR's LED indicates when the unit detects movement for 90 seconds. When in the LED mode the PIR will transmit every time the LED lights. There must be 10 seconds of inactivity between each test. *THE TEST MODE WILL TIMEOUT AFTER 90 SECONDS AND RETURN TO THE DETECTION MODE.*

TRANSMITTER LOCKOUT: In the Radio Mode the transmitter will transmit once, then "lockout" (i.e. not transmit again) unless the detector sees no motion for at 3 to 5 minutes. Any movement prior to 3 undisturbed minutes causes this timer to reset and another 3 undisturbed minutes would be required before the unit will transmit.

INSTALLATION CONSIDERATIONS

- **REFERENCE POINT** - Mount the PIR so there is a reference point (such as a wall) at the end of its pattern.
- **FOR BEST DETECTION** - Mount these sensors so an intruder will most likely walk **ACROSS** the beams.
- **PERMANENTLY MOUNT THE PIR** - Do not simply set it on a shelf without screwing it down because the customer might move it and change its field of view.

- **MOUNTING HEIGHT** - Mount at between 5 and 8 feet high for best detection.
- **PETS** - If pets will be allowed in the PIR's field of view you must use the optional PIR lens for Pet Patterns. The down finger zones are eliminated, thus making it possible for pets to have access to the protected area.
- **DON'T ATTEMPT TO MASK OFF ZONES** - Instead select an optional lens to provide the desired coverage.
- **LOCATION** - Even though these PIR's are highly immune to false alarms you should follow these standard Passive Infrared locating guidelines:
 - * Don't locate in direct sunlight.
 - * Don't aim at air conditioners, heat vents, wood stoves, fireplaces, etc.
 - * Don't aim at moving objects (curtains, etc).
 - * Don't aim at solar heated walls or uninsulated metal walls.
 - * Do attempt to mount on an outside wall facing in.
 - * Do mount on a surface which is rigid and free from vibration.

As with any radio transmitter, avoid mounting on or near large metal objects such as a heat duct or foil wallpaper.

LENS REPLACEMENT

See the DS923 Installation Instructions included to replace lenses. Several lens options are available for the DS923 PIR. If you require a different detection pattern for your application, select the appropriate lens from the chart at right.

<i>ITI Part #.</i>	<i>Pattern</i>
13-167	Pet Avoidance
13-166	Long Range Barrier
13-168	110° Wide Angle

INSTALLATION

Install the PIR according to the Installation Instructions included with the DS923 detector.

TRANSMITTER INSTALLATION

The transmitter circuit board connects to the PIR circuit board by a 4 pin connector on the top of the PIR circuit board. You must remove the vertical adjustment screw on the PIR circuit board if you wish to remove the PIR or transmitter circuit board.

You will notice the guide rails on either side of the PIR base that holds the semicircular transmitter board.

To remove, simply slide the transmitter board away from the PIR board. To reinstall, position the transmitters connector pins into the PIR boards connector and slide on. When reinstalling, take note that the transmitter circuit board will have a fairly tight fit in the PIR case. If you have installed each board and the PIR case cover does not close easily, please check the position of both circuit boards.

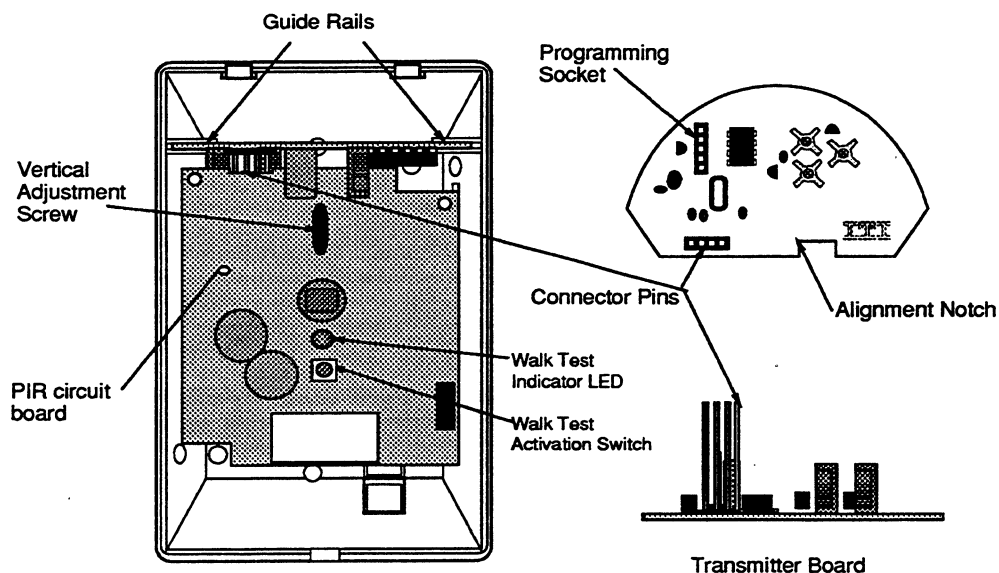

PROGRAMMING

The programming cable for this PIR must be plugged in *backwards* (in relation to other ITI sensors) to program correctly.

The open end of the programming cable must face *away* from the black chip. With the Handheld Programmer, program the PIR as a Motion Sensor, Type 2. *NOTE: The lockout option should not be used on a DS923 PIR.*

Typically the sensor number for an SX-V system will be numbers 60-67.

TESTING THE PIR

Walk Test

A momentary switch on the detector board (refer to the DS923 installation instructions) enables a walk test LED. After pressing the switch, replace the cover and position the PIR as desired and wait at least 15 seconds for the PIR to stabilize. Then walk through the field of coverage as shown in the DS instructions and observe the LED. When the LED turns on, the transmitter will transmit the alarm signal to the CPU and the walk timer will restart. After the LED turns on, stay out of the field of coverage for 15 seconds before retesting. After approximately 75 seconds of **NO ACTIVITY IN THE FIELD OF COVERAGE**, the walk timer will flash the LED indicating the PIR is returning to the normal mode and is ready for service.

If rated range can not be achieved, try sliding the detector board up or down to assure the pattern is not aimed too low or too high (use the battery to slide the board up and down). Tighten the adjustment screw and replace the cover. *The detector board provides lockout when in the walk test mode.*

Final Test

Place the CPU in sensor test. When performing the sensor test remember to always wait at least three minutes between tests. Once the sensor has sent an alarm, you must wait three minutes to send another. *Do not enter the PIR field of view during this 3 minute time.* The lock out feature will prevent the PIR from sending alarms less than three minutes apart.

SHOCK SENSOR

ITI Part #60-107 (white)

ITI Part #60-192 (brown)

(Not investigated by Underwriters Laboratories Inc.)

The Shock Sensor serves a variety of functions: It has two built-in reed switches and may detect openings and closings (like a Door/Window Sensor); it may also be connected to a variety of shock detectors. There is a limit of five detectors (of any kind) per sensor, and one external reed switch. The sensitivity of the detectors can be adjusted by using the built-in adjustment pot on the transmitter. Shock Sensors send a signal to the CPU every 69 minutes. Supervisory problems are detected and reported in the same way as for a D/W Sensor. The Shock Sensor uses a 3.6 Volt lithium battery which should last 5-8 years under normal conditions. If the battery fails, a supervisory indication will be detected and reported by the CPU.

Removing the sensor cover causes the sensor to transmit a "TAMPER" signal to the CPU. If the CPU is armed to a protection level in which the tampered sensor is active, a TAMPER ALARM signal is sent to the Central Station.

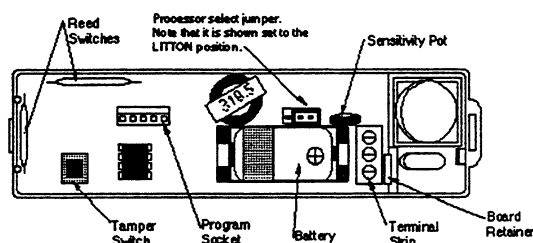

If the tampered sensor is not active in the current level, the CPU will not go into alarm but will remember the TAMPER signal and "PROTEST" (as if the sensor had been left open) the next time an attempt is made to arm the system. Replacing the sensor cover closes the tamper switch but does not send a signal to the CPU. The CPU will still "PROTEST" until a "RESTORE" signal is heard from the sensor. This can be accomplished by activating the Shock Sensor or reed switch. Temperature Range is 10°F - 120°F.

INSTALLATION

IMPORTANT CAUTION!! It is important to be free of all static electricity when handling transmitters. Touch something metal before handling the transmitter circuit board.

- 1 Remove the sensor cover by pressing on the cover end to disengage the top on the cover from the slot in the sensor base.

NOTE: If only the self-contained reed switches will be used, a jumper must be placed between terminals 2 and 3 on the transmitter circuit board.

- 2 Remove the circuit board to expose the two mounting holes.
- 3 Secure the sensor using the two screw holes in the base. One is larger to allow alignment of the sensor. Use #6 screws to mount on wood. Use appropriate fasteners if you are securing the sensor to other material.
- 4 Put the sensor circuit board back into place, sliding the reed switch end in first then snapping the board in place. Be sure the locking tab is secure and the board is level.
- 5 Use the Hand-Held Programmer to program the sensor. Be sure the processor select jumper is in the Litton position.

ADJUSTMENTS / TESTING

- 1 Arm the system to Level 9 - SENSOR TEST.
- 2 Sensitivity - The sensitivity pot in the ITI Shock Sensor is used to select the proper shock detection level for the initial high energy, high frequency impact. **TURN THE ADJUSTMENT POT CLOCKWISE TO INCREASE SENSITIVITY, COUNTER CLOCKWISE TO DECREASE SENSITIVITY.**
- 3 Jumper - Use jumper selection shown for Litton detectors.
- 4 Level 9 Test Beep - When armed in Level 9, the SX-V will sound a loud beep when a shock detector receives a high energy impact, or when the reed switches are activated.
- 5 Testing - The sensitivity of the ITI Shock Sensor should be set to a level sensitive to a forceful impact (not to break the glass), but not sensitive to normal ambient vibrations. Check for proper coverage by hitting the window glass two times at the point furthest from the sensor. Use a solid object such as the plastic handle on a screwdriver.

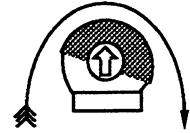

REMEMBER: WAIT 20 SECONDS BETWEEN EACH TEST. REPLACE SENSOR COVER AFTER ADJUSTMENT. TEST SENSOR IN ORDER TO RESTORE SENSOR.

SP3237 ITI Part #13-005 (white), #13-011 (brown)
(Not investigated by Underwriters Laboratories)

The best location for the Litton detector is on the window frame at right angles to the glass being protected. It should be as close as possible to the glass and the wire leads should either go straight up or straight down.

INSTALLATION

- 1 Mount the Shock Detector's bracket with a screw or RTV adhesive. Remember the detector leads must be straight up or down in order to work. Keep sensor within two (2) inches of the glass being detected.
- 2 Install the detector in the bracket.

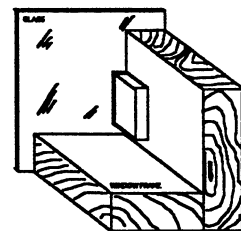

CONNECTING THE DETECTOR

- 1 Connect a single SP3237 Shock Detector to the Shock Sensor as shown. Be sure to crimp or solder the black and green leads together if you aren't adding any external reed switches. They act as a tamper loop.

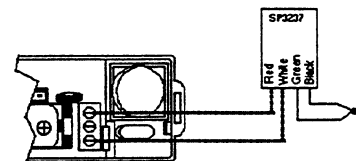

Shown wired for non reed switch use. White wire would go to #2 if internal reed switches are used.

2 Connect a maximum of five detectors to one SHOCK SENSOR. If using multiple detectors they must all be mounted exactly the same way on a similar surface protecting similar glass areas. This is because the individual detector sensitivity is not adjustable, the only adjustment is on the transmitter itself and thus it will be set the same for all detectors.

If an external reed switch is to be used, connect the switch in series with the BLACK and GREEN lead as shown.

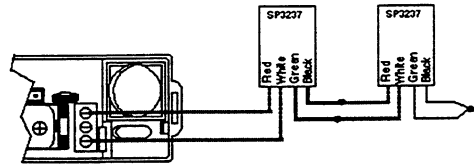

If internal reed switches are not used, connect one or more shocks to 1 & 3 as shown. Always solder or crimp black and green leads of last unit.

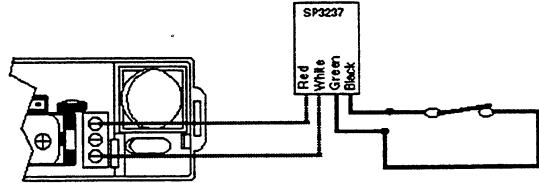

SP3227 ITI Part #13-214 (white) (Not investigated by Underwriters Laboratories)
 The SP3227 is a recessed shock sensor fitted inside an ITI Shock Sensor. The Recessed sensor can be used inside the shock sensor or can be wired directly to the shock sensor for remote sensor mounting. The same mounting considerations hold true for this version of sensor. It must be within 2 inches of the glass it is detecting.

The drawings on the right shows the proper position on the arrow on the shock detector. The position of the arrow is only a concern when the sensor is mounted vertically. If the sensor is mounted horizontal (flat) the arrow can point in any direction. Having the detector arrow in the position shown will meet most application needs.

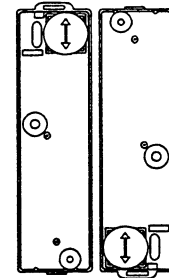

Push wires and SP3227 up through the 3/4" hole until the detector seats flush with the bottom of the plastic base.

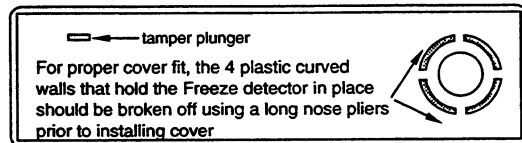
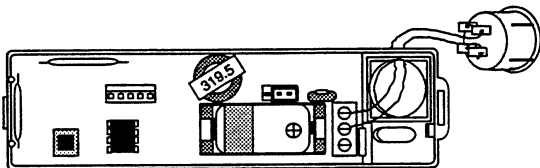

The average sensitivity setting would be with the arrow pointing at 12 O'clock. Clockwise direction of rotation increases chock sensitivity. When the Sensor is mounted in certain orientations it is hard to access the pot to set sensitivity. To do this you must unsnap the PCB from the chassis, make pot adjustment, re-snap PCB onto plastic chassis and re-test sensor. Continue this operation until the sensitivity is set correct. See testing.



Terminal connections are shown NOT using internal reed switch. To use internal reed switches, connect the detector to terminals 2 & 3.

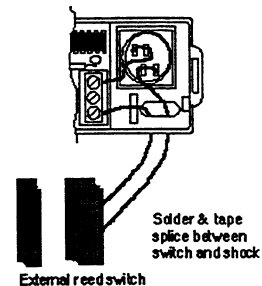

FREEZE SENSOR

ITI Part #60-185

(Not investigated by Underwriters Laboratories)

The ITI Freeze Sensor contains a freeze detector wired to a transmitter. The most common use of a Freeze Sensor is to detect a furnace failure in a home or business. The Freeze Sensor will activate a switch when the temperature drops to about 45°F. In the event the Freeze Sensor is ever tripped, it typically must be heated up to 55° F to 60° F for it to reset.



INSTALLATION CONSIDERATIONS

More than one Freeze Sensor may be necessary to adequately cover a large home or business. If only one Freeze Sensor is installed, keep in mind that it monitors an open area of about 900 square feet (30' x 30'). Thus, be sure to install the Freeze Sensor in an area of the home or business that is likely to get cold first in the event of a furnace failure. In general, mount a Freeze Sensor on an interior wall in an open, heated area of the building.

DO

- locate the sensor in an area that is likely to get cold first.
- locate the sensor on an interior wall where there is free movement of air.

DON'T

- locate the sensor in the same room as a furnace, water heater, or any other heat source that may stay warm after the furnace failed.
- locate the sensor on an outside wall or near the basement floor.

INSTALLATION OF THE FREEZE SENSOR

- 1 Remove the transmitter cover by pressing on the cover end to disengage the top of the cover from the slot in the sensor base.
- 2 Remove the circuit board to expose the two mounting holes.

Mount sensor with the sensing element down. This will prevent damage to the transmitter board when the "ice cube" test is performed in the next section.

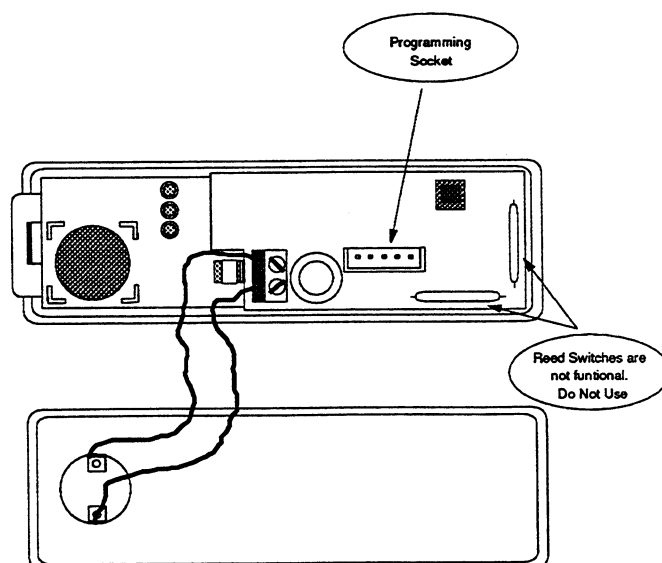

- 3 Secure the sensor in the position shown at right. One of the screw holes is slightly larger to allow for alignment. Use #6 screws to mount on wood or appropriate fasteners if mounting on other material.
- 4 Replace the sensor circuit board. Place the reed switch end in first then snap the board in place. Be sure the locking tab is secure.
- 5 If you haven't done so, program the sensor typically 12 - 17 (see programming section).
- 6 Replace the transmitter cover.

TESTING THE FREEZE SENSOR

Arm the CPU to Level 9 and place an ice cube in a plastic bag (or freeze mist spray) against the flat surface of the thermostatic disc. The Freeze Sensor will activate the transmitter as soon as it is cooled to 45°F. This should take less than five minutes. To reset the Freeze Sensor, warm it with your thumb.

NOTE: If the Freeze Sensor is not tested shortly after it has been programmed, an open sensor condition will be displayed on the CPU. This is because the CPU has not received a restore signal from the sensor when the tamper switch was activated during programming. When the sensor sends the supervisory signal (within 69 minutes) the restoral will be given. *Upon a successful test of the sensor, the sensor will be reset and the CPU will no longer protest.*

PORTABLE PANIC TRANSMITTERS

Portable, hand held "Panic" Transmitters are typically used as panic buttons to activate 24-hour "Police Emergency" alarms or 24-hour "Medical Emergency" alarms. The transmitters can be activated by pressing the ALERT box or boxes and holding for one second.

ITI Part # 60-358

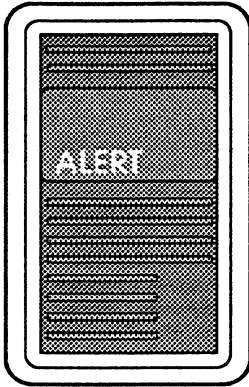

60-149

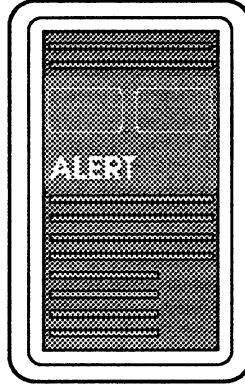

BATTERY POWER

The Portable Panic Transmitter is powered by a 9 volt alkaline battery which should last 12 to 18 months. A battery check signal is sent every 69 minutes by the transmitter. If a low battery is detected, the Trouble LED and the sensor number will be lit on the SX-V display. This signal is similar to the supervisory signal, however, the CPU will not issue a supervisory alarm if it does not hear from the Panic Transmitter. This allows the Panic Transmitter to be carried away from the premise by the user.

Programming

To gain access to the programming socket and battery, push in on the cover and slide it up and off.

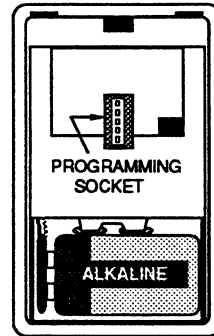
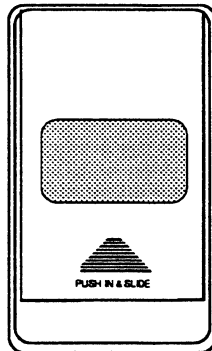

The Panic Transmitter is typically programmed with sensor number 02 - 07 or 10 - 11. Since these sensor numbers are given Fire/Panic Priority, 16 rounds of data are sent when the transmitter is activated. See F10 Sensor Test in Testing section.

NOTE: *If using the PPB with an SX-V systems having software versions earlier than 9-1-89, the Panic sensor number must be regrouped to a letter code "G" by the CS-4000. U.L. requires Panic Transmitters to be programmed as Sensor Type 10 or 11.*

PENDANT PANIC SENSOR

ITI Part # 60-329

(Not investigated by Underwriters Laboratories)

The Pendant Panic Sensor is designed to be carried by an individual in either a pocket or purse, or (if removeable cord is attached) may be worn around the neck as a Pendant.

The circuitry for the Pendant Panic Sensor is very simple.

There are no reed switches or external wiring, and the sensor is powered by a 3.6V Lithium battery. When the special push-button switch is activated by pressing the PUSH button on the end of the sensor, a violation signal will be sent to the CPU.

An unobstructed signal may be received at a distance of up to 500' from the CPU. See the reverse side of this sheet for opening instructions.

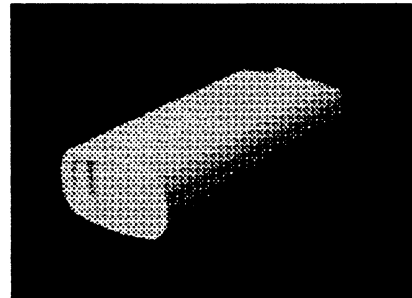

PROGRAMMING

The procedure for opening the case is on the following page. Program the Pendant Panic Sensor using the Hand Held Programmer. Programming is done as for any portable Panic Button. With the SX-V, Panic Sensors are typically programmed to number 02-07 or 10-11. This sensor has a Fire/Panic priority. When using the programming cord, observe polarity.

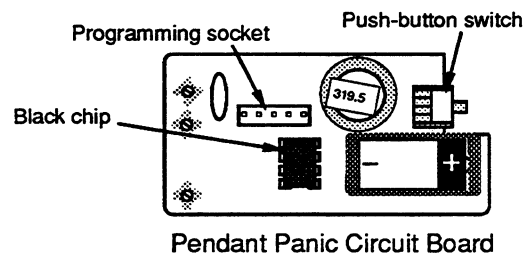

Once the Pendant Panic Sensor is programmed, it is ready to go. Simply slip it into your pocket, or if you wish to wear the sensor around your neck, insert the cord under the cord clip on the upper end of the sensor.

TESTING

To test the Pendant Panic Sensor, put your system into Level 9, Sensor Test, and press the Pendant Panic button. The system should respond as if to an alarm, with the violated sensor's number. If it does not respond, check your programming and test again.

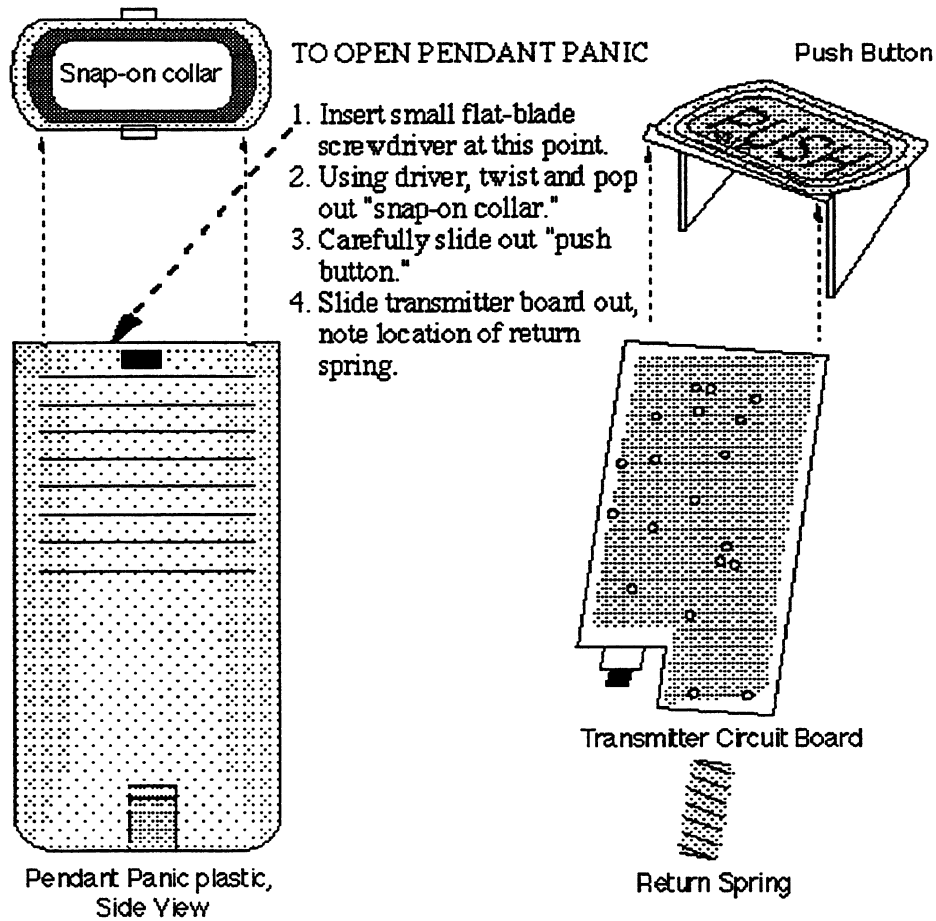

To re-assemble the unit, just repeat the four steps listed above, in reverse order.

It is important to note that the panic's plastic housing may become damaged by repeatedly opening the unit. Therefore care must be taken when inserting the small screwdriver.

SIRENS

The SX-V CPU initiates a variety of alarm and system status sounds. There are several types of sirens available. Both alarm siren sounds and status “beeps” can be made to sound throughout the installation site.

INTERIOR AND EXTERIOR SOUNDS

POLICE SIREN - loud intermittent tone siren sound.

FIRE SIREN - loud steady tone siren sound.

INTERIOR SOUNDS ONLY

AUXILIARY SOUNDS - low volume, on-off on-off beeping.

STATUS SOUNDS - low volume beeps which indicate the CPU's current protection level.

PROTEST BEEP - low volume rhythmic two-tone beeping sound when an arming attempt is made which indicates a Trouble or Supervisory condition or that a sensor is open.

TROUBLE OR SUPERVISORY BEEPS - six quick low volume beeps repeated every sixty (60) seconds. Occurs as an automatic indicator if a trouble or supervisory condition exists and no change occurred in arming level for 10 hours.

CHIME BEEP - a pair of low volume tones which indicates a perimeter sensor has been opened and the CPU is armed to protection level 2.

SENSOR TEST SOUND - loud single tone or series of tones heard when testing sensors in protection level 9.

EXIT DELAY SOUNDS - Low volume status sounds which indicate the beginning of the Exit Delay Time when levels 3 - 6 are selected. Can be programmed to sound repeatedly for the duration of the Exit Delay Time by programming F00 into the CPU.

ENTRY DELAY SOUNDS - Low volume repeated status sounds which indicate that the Entry Delay Time is in progress.

HARDWIRE INTERIOR SIREN AND PIEZO

ITI Part #60-278

The SX-V Interior Siren and Piezo is a combination unit that produces both low volume status sounds and high volume siren sounds. It is located in areas where the SX-V status and siren sounds need to be heard. Each unit draws 75 milliamps of current in alarm. It contains three piezo sirens that can deliver a 85 dB siren level in high level alarm. The trouble sound current draw is approximately 12mA.

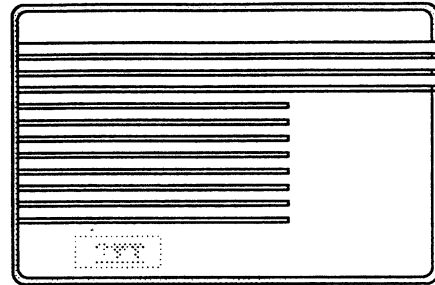

APPLICATION CONSIDERATIONS

- The Hardwire Interior Siren and Piezo can be mounted in any location where the status sounds need to be heard.
- The number of sirens that can be installed depends on what other devices are being powered from the CPU. The total current available for all devices powered from the CPU is 500 milliamps.

INSTALLATION INSTRUCTIONS

- 1 Using 22 gauge or greater, 4 conductor stranded wire, run cable from the CPU to the siren location. **Note:** The CPU should be OFF when connecting the siren/piezo wires.
- 2 Remove the front cover of the siren by removing the 2 bottom screws. Next, remove the 4 screws that secure the piezo assembly, and pull the piezo assembly off the base.
- 3 Feed the cable through the circular cut-out in the back of the base. Two mounting holes are provided to mount the base to the wall with the proper anchors and screws.
- 4 Resecure the piezo assembly to the base.
- 5 Connect the 2 wires from the double piezo board to the 2 left screws, and the single piezo wires to the 2 right screws.
- 6 Follow the wiring diagram for proper terminations. **Note:** the double piezos are activated for fire and burglary alarms only. The single piezo activates for both status and alarm sounds.
- 7 Install a jumper between CPU Terminals 10 and 11. The double piezos will not activate if this jumper is not in place.

Note: If you are using more than 1 Hardwire Interior Siren and Piezo, the connections to the piezos must be in parallel with polarity observed in order to maintain the siren volume. *In U.L. listed systems, terminals 1 and 2 are connected to terminals 10 and 13 respectively of the SX-V. Terminals 3 and 4 are not used.*

HARDWIRE INTERIOR SIREN (HIS)

ITI Part #60-136

A Hardwire Interior Siren (HIS) is available from ITI. Up to 3 can be wired to the CPU using 2 conductor wire. Standby power is provided by the CPU. The total number of HIS installed, is based on the maximum alarm current rating of 500mA total for the CPU. Each HIS draws approximately 50mA.

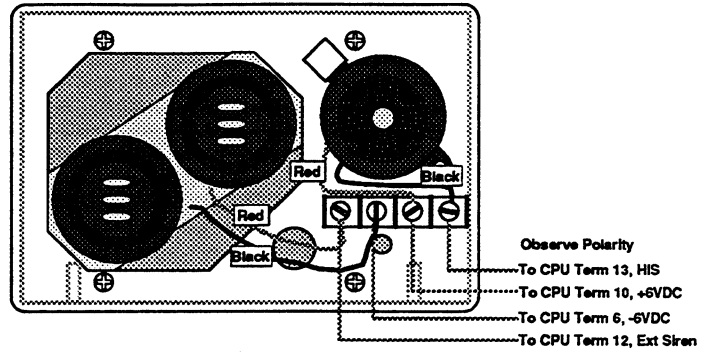

HARDWIRE INTERIOR SIREN SOUND OPTIONS

The HIS can produce alarm or alarm and status sounds. There is an “F” feature that determines which sounds the HIS will produce. With F11 programmed into the CPU memory, the HIS will produce ONLY the emergency sounds. You would program in F11 if a HIS was, for example, placed in a child’s bedroom where emergency sounds were wanted, but status sounds were not. With F11 not in the CPU memory, the HIS will produce emergency sounds and the various status beeps. The CPU powers up without F11 in its memory.

NOTE: F11 shall be “not set” when the 60-143 Hardwire Touchpad is not used or is used but the status sounds are disabled. To add optional feature number F11 to the CPU memory, see the Programming Section.

CONNECTIONS

- Connect POSITIVE on the HIS to SCREW 10 (+OUT) of the CPU terminal strip.
- Connect NEGATIVE on the HIS to SCREW 13 (HIS) of the CPU terminal strip.
- Multiple Hardwire Interior Sirens would be connected in parallel.

WARNING - Do not store any excess siren wires behind the circuit board.

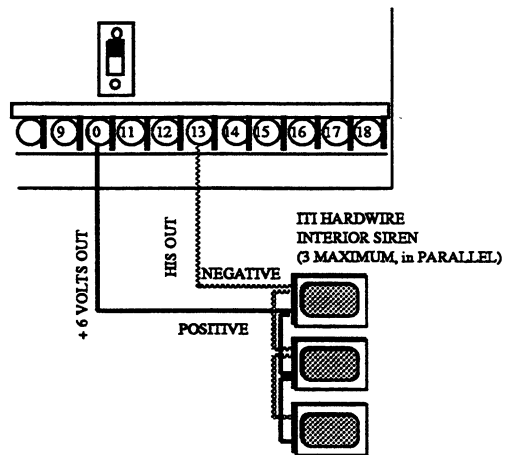

FAIL TO EXECUTE BUZZER

ITI Part #30-023

Remove an available knock-out on bottom of the SX-V Cabinet and install buzzer as shown. From bottom (CPU outside), screw retaining ring tight.

- Connect RED wire to SCREW 10 (+OUT) of the CPU terminal strip.
- Connect BLACK wire to SCREW 13 (HIS) of the CPU terminal strip.

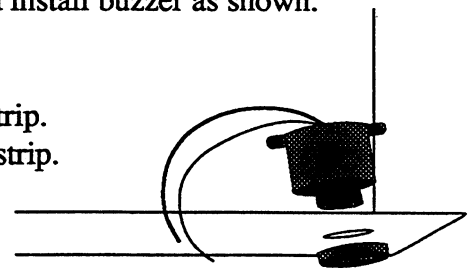

HARDWARE EXTERIOR SIREN

ITI Part #13-046

The Hardwire Interior Siren must be hardwired to the CPU. Only full volume sounds (police and fire emergency or Level 9 sensor beeps) will be heard from the Interior sirens. The current draw of the siren driver speaker combination should not exceed 500 mA. The total current draw of both the Siren and Auxiliary outputs shall not exceed 500mA. Current draw at 6V for the 13-046 siren is 70mA.

HARDWARE EXTERIOR SIREN CONNECTIONS

WARNING: Be sure you fully understand the wiring connections below. Failure to follow instructions may result in blown fuses and/or may permanently damage the CPU circuit board or your siren.

- 1 To provide DC power to the Interior siren relay, connect a jumper from screw 10 to screw 11 on the CPU.
- 2 Connect the RED LEAD to screw 12.
- 3 Connect the BLACK LEAD to screw 6.

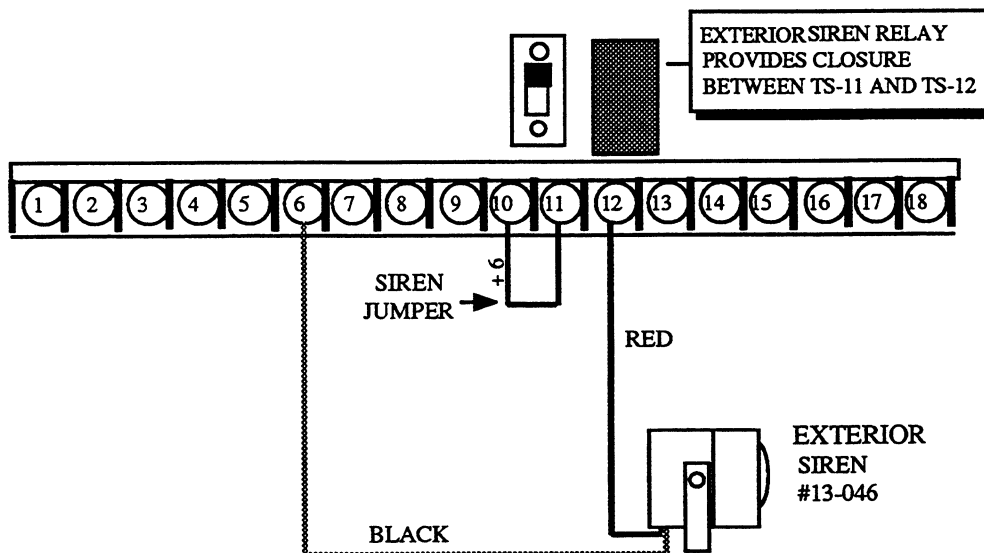

REMEMBER: Do not store any excess siren wires behind the CPU circuit board.

NOTE: The Interior Siren output will be delayed for 15 seconds if Optional Feature F02 is set. See Programming Section.

The 13-046 is intended for indoor use only.

PHONE JACK SIREN (PJS)

ITI Part #60-108

(Not investigated by Underwriters Laboratories, Inc.)

(Not to be used in Canada)

(Not listed by California State Fire Marshall)

ITI's Phone Jack Siren can be used with any alarm system, either hardwired or wireless, that supplies either a 6 or 12 volt DC output during an alarm. The PJS is installed in place of existing modular phone jacks. The PJS can be recess mounted if a box is already in place, or the back box which is sent with each unit can be used for surface mounting.

PRELIMINARY CONSIDERATIONS

- This product has been designed to take advantage of existing extra telephone wiring where available.
- The use of this unused wiring is regulated on a state-by-state basis. We suggest that you check with the Public Utilities Commission in your state for an opinion before using this product.

Up to three PJS's can be wired to the SX-V CPU.

INSTALLATION INSTRUCTIONS

- 1 Remove an existing RJ-11C telephone jack from the wall. Check to be sure there are extra wires that are not used. Also note which two wires (typically red for Ring and green for Tip) are connected to the existing jack.
- 2 Disconnect Tip and Ring from the existing jack and connect them to the appropriate Tip and Ring screw terminals on the back of the PJS.
- 3 Connect the two formerly unused wires (typically black & yellow) to the PJS. You *must* observe polarity.
- 4 These two wires (black and yellow) should now run all the way back and end some where near the surge protector where the incoming phone lines enter the home from the telephone pole. Ultimately, they will be connected to the interior siren voltage output of the SX-V CPU.

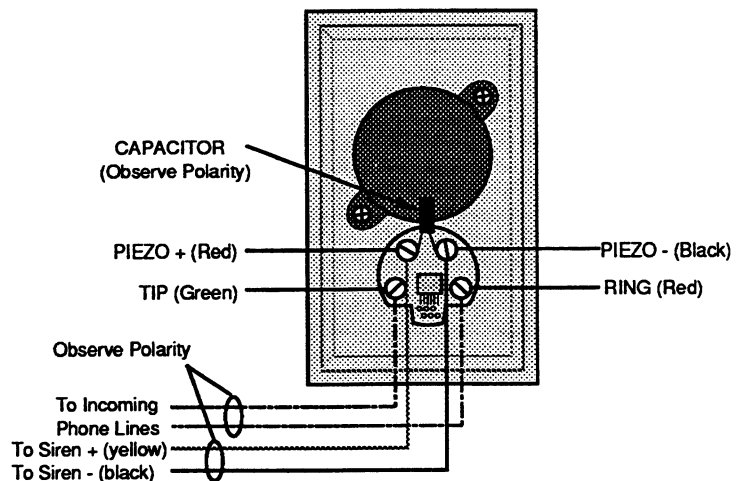

CONNECTING THE PHONE JACK SIREN

OPTION ONE:

One option is to connect the yellow and black wires from the PJS (that now terminate near the surge protector) to a two conductor wire that you run back to the control panel siren voltage outputs.

To connect a PJS to an ITI SX-V control panel:

- 1 Connect the yellow wire (PJS +) to screw #10 (+out) on the CPU terminal strip.
- 2 Connect the black wire (PJS -) to screw #13 (HIS) on the CPU terminal strip.

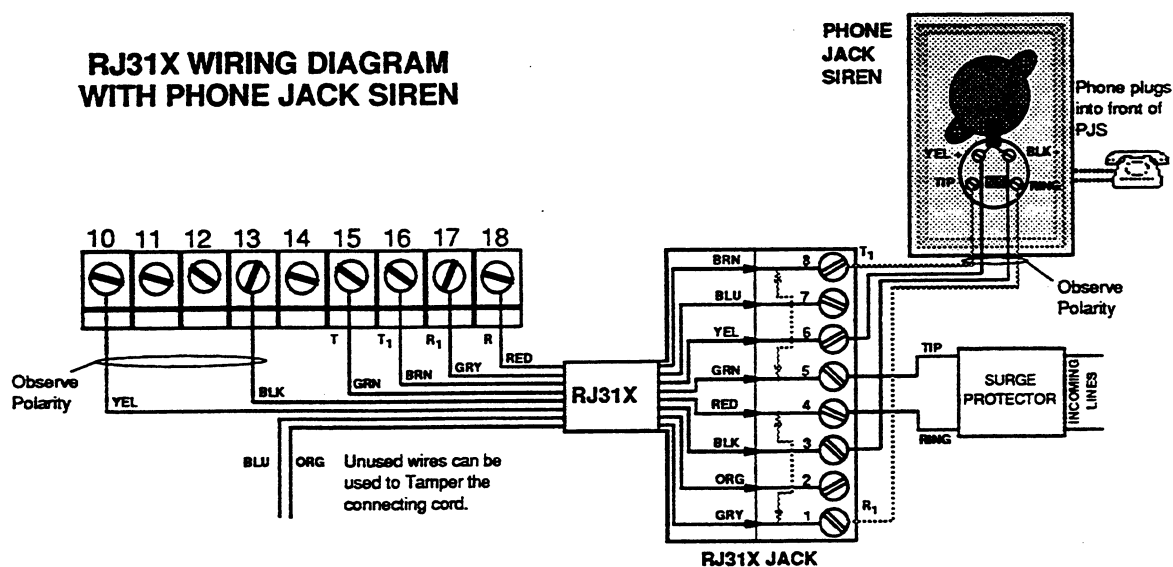

OPTION TWO:

As an alternative to running a separate two conductor cable from the CPU to the wires coming from the PJS. You can use the RJ-31X cord. Instead of running a four conductor RJ-31X cord from the CPU to the RJ-31X Jack, use a 6 or 8 conductor cord. Two extra conductors are used to bring siren power from the CPU to the RJ-31X Jack. Then, instead of wiring the RJ-31X Jack to the incoming phone lines using a four conductor cable, use six conductor cable. Connect the two extra wires to the wires that are coming from each of the PJS's that you have installed in the home or business.

- 1 Connect the four phone wires (Green, Brown, Gray & Red) from your RJ-31X Cord to the CPU as usual.
- 2 Connect the fifth wire (yellow) from the RJ-31X cord to the screw #10 on terminal strip (+out)

- 3 Connect the sixth wire (black) from the RJ-31X cord to the screw #13 on terminal (HIS).

Up to this point you have connected the siren output from the control panel to the RJ-31X Jack. These two wires will terminate in the jack on screw terminals #3 (siren -) and #6 (siren +).

- 4 Now, instead of running a four conductor wire from the RJ-31X Jack to the incoming phone lines, run a six conductor.
- 5 Connect the four telephone conductors as you normally would.
- 6 Connect the fifth conductor to the RJ-31X Jack terminal #6 (siren +). Connect the other end of this wire to the yellow wire (PJS+) coming from each of your PJS's.
- 7 Connect the sixth conductor to the RJ-31X Jack terminal #3 (siren -). Connect the other end of this wire to the black wire (PJS-) coming from each of your Phone Jack Sirens.

REMEMBER: The CPU phone cord must be plugged into the RJ-31X jack for the PJS to work.

SPECIAL NOTE: When connecting the PJS to an ITI SX-V control panel the optional feature number F11 can be used to select whether the PJS gives status and alarm sounds or alarm sounds only. F11 OFF = Alarm and Status Sounds, F11 ON = Alarm Sounds only.

TAMPERING THE RJ-31X JACK

By using an 8 conductor RJ-31X cord you can tamper the cord against removal. You simply need to connect the two unused wires (orange and blue) in series with the CPU tamper switch and install a jumper in the RJ-31X jack to accomplish this.

- 1 Connect the blue and orange in series with the CPU tamper switch.
- 2 Install a jumper between screw 2 and screw 7 inside the RJ-31X jack and plug the RJ-31X cord back into the RJ-31X jack.
- 3 To test the tamper circuit, put the CPU in Level 3-7 and remove the cord. This will test the tamper circuit. The CPU will go into a 92 alarm.

Remember: The phone cord must be plugged into the RJ-31X jack for the PJS to work. In order to hear the siren, in the event of cord removal, you must have a wireless interior siren or a piezo directly connected to the alarm panel. However, you will always have visual identification at the CPU if the phone cord is disconnected from the RJ-31X jack.

WIRELESS INTERIOR SIREN (WIS)

ITI Part #60-353-235 (CSA 60-275)

The Wireless Interior Siren (WIS) is used as a siren/annunciator in areas of the installation where the CPU's siren and status sounds need to be heard. Any number can be installed and no wiring to the CPU is required. The WIS is simply plugged into a live, non-switched, 110 volt AC wall outlet. The WIS receives its signals from the CPU over the AC power line in the house. The WIS also contains a 9 volt alkaline or optional rechargeable NiCad** backup battery to supply power in the event of an AC power failure.

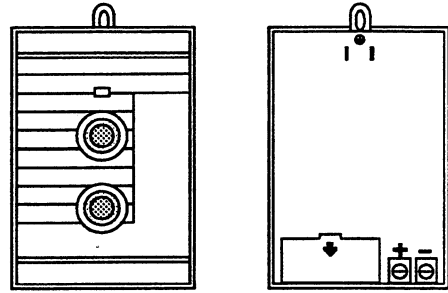

The battery will supply at least 4 hours of standby power and will also provide 85 dB minimum sound level output for at least 4 minutes. If the backup battery becomes low, the WIS will beep every 60 seconds until the battery is replaced or fails. The WIS also has screw terminals which are used to connect another siren. The terminals provide 7.5 volts DC and 100 milliamps maximum current.

NOTE: U.L. applications require either Duracell Model MN1604 or Eveready Model 522 Alkaline Batteries.

** The Saft Nicad Battery #34-010 will not be used in U.L. listed applications.

WIS DIP SWITCHES OPTIONAL FEATURES

The Wireless Interior Siren has three DIP switches located in the battery compartment which allow you to modify the operation of the WIS to fit the needs of the installation.

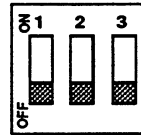

SWITCH 1 This DIP switch allows either an alkaline or NiCad battery to be used as the battery back-up.

- If SWITCH 1 is OFF, an alkaline battery must be used.
- If SWITCH 1 is ON, a 1 milliamp trickle charge is applied to the battery terminals to charge an optional NiCad battery.

CAUTION: NEVER have Switch 1 ON if you will be using an alkaline battery. Alkaline batteries may leak or explode if recharged.

SWITCH 2 This DIP switch allows the choice of either High Level Alarm sounds only or all Alarm and Status sounds from the WIS.

- SWITCH 2 OFF, all Alarm and Status beeps will sound from the WIS.
- SWITCH 2 ON, only High Level Alarm (Police and Fire) will sound from the WIS.

SWITCH 3 This controls whether a 15 second delay will be applied to a siren wired to the terminals on the back of the WIS.

- SWITCH 3 OFF, the siren attached to the terminals will activate at the same time as the WIS.
- SWITCH 3 ON, the siren attached to the terminals will be delayed for 15 seconds before sounding.

NOTE: The siren delay on the WIS is independent of the CPU Optional Feature F02. However to avoid any confusion, it is recommended that if F02 has been programmed into the CPU, then SWITCH 3 should also be in the ON position if a siren is attached.

In U.L. applications, the following settings are required: Positions 1, 2, 3 = off.

INSTALLING A WIRELESS INTERIOR SIREN

- 1 Plug the WIS into a non-switched outlet.
- 2 Be sure to secure the WIS to the outlet with the center outlet screw so that it cannot be accidentally unplugged.
- 3 Press the STATUS button on a Touchpad. The CPU's House Code will automatically be read and entered into the WIS. Communication from the CPU to the WIS is verified by the LED on the front of the WIS. The LED flashes every time it receives a valid transmission.

NOTE: If you ever wish to change House Codes, simply unplug the WIS and disconnect the battery. After a minimum of 30 seconds, reconnect the battery and plug the WIS back into the outlet. Pressing the STATUS button will reprogram the WIS with the House Code of the CPU.

WARNING - NEVER OPEN THE WIS WHILE IT IS PLUGGED INTO A LIVE CIRCUIT, SERIOUS INJURY OR DEATH COULD RESULT FROM ELECTRIC SHOCK.

CONNECTING ANOTHER SIREN TO THE W.I.S.

The WIS has two screw terminals on the back of the unit which can be connected to another self contained siren (7.5 VDC 100 mA maximum). By taking advantage of these terminals which are already connected to the CPU, you can avoid doing a "home run" wiring from the siren to the CPU. Connect the siren to the WIS as shown. Polarity must be observed.

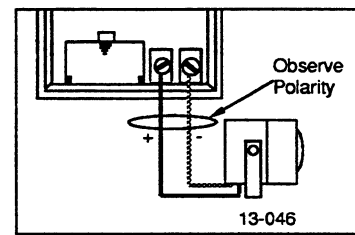

NOTE: Only the POLICE and FIRE alarm sounds will be activated from these terminals.

WIS INTERFERENCE AND PHASING PROBLEMS

In a small percentage of installations a Wireless Interior Siren may experience problems. **SIGNAL BLOCKING** - Occasionally appliances (especially TVs) can act as a filter and will block signals being sent to a WIS. If you experience signal blocking, either use a different circuit than the TV or be sure the WIS is on the near side of the circuit in relation to the CPU and the TV is beyond the WIS.

PHASING PROBLEMS - AC power coming into an installation site is usually broken into two different 110 volt lines, with each line serving different areas. These different lines are referred to as different line phases. Sometimes when a CPU is plugged into one phase and a WIS into another, signals will not get through properly. To overcome phasing problems, move the WIS to an outlet that is in phase with the CPU (or move the CPU to an outlet in phase with the WIS). If this is not possible, you may want to switch to a Hardwired Interior Siren or a Phone Jack Siren.

INTERFERENCE - The WIS uses line carrier technology for signaling. Under severe circumstances, RF interference, AC power spikes, and other "noise" on an AC power line may cause any line carrier device to operate erratically or intermittently. If you experience these problems, try installing the WIS on a different electrical circuit. If that does not help, you should install a Hardwire Interior Siren or Phone Jack Siren in place of the WIS.

PROGRAMMING THE SX-V CPU

CPU POWER-UP PROCEDURE

- 1 Turn the power switch ON. Panel will show “r rr” in the protection level and sensor number display windows. During the next 2 1/2 - 4 minutes the CPU completely checks its RAM memory. If it finds a problem, the display will show “b ad”.
- 2 When the self test is complete the CPU will respond as follows:
 - Audible trouble beeps will sound once every 60 seconds if interior sirens are installed.
 - Protection level display window will show “0”.
 - CPU sensor number display will show “CS” (checksum).
- 3 If the CPU does not respond as described above:
 - Verify that the transformer is supplying 9-13.6 VDC to the CPU panel.
 - Verify that the outlet the transformer is plugged into is providing 110 VAC.
 - Verify that the transformer is providing approximately 7 - 10 VAC on screw terminal 4.
- 4 Clear the RAM only if the CPU comes on without giving the “CS” indication in the sensor number display following these steps:

The RAM Memory may have to be manually reset by the technician;

 - If data from factory testing remained in the memory causing the CPU to not enter the RAM clear function upon initial power up,
or
 - For troubleshooting to set all CPU parameters to known values.

Clearing the memory on the SX-V CPU causes the CPU to perform a 2 1/2 - 4 minute RAM test. The RAM is thoroughly tested and if irregularities are discovered the CPU will indicate that there is a problem. Any programmable features, sensor numbers, phone numbers, account number etc. will be erased when the RAM is cleared. *The CPU must be completely reprogrammed to become functional again.*

- 1 The CPU must be turned ON and the power transformer must be supplying voltage.
- 2 Locate the RAM CLEAR PINS and jumper on the CPU board. See wiring diagram on page 18 for location. The jumper will be installed connecting the Top and Center pins.
- 3 Remove the jumper from the Top and Center pins and install it on the Bottom and Center pins. This will force the CPU into its RAM check routine. (The display will show “r rr”)
- 4 **IMPORTANT:** As soon as the CPU display shows “r rr” remove the jumper from the Bottom and Center pins and reinstall it on the Top and Center pins.

SET CPU HOUSE CODE

- 1 Slide the CPU's PROGRAM SWITCH to "ON" (up) to select Program Mode.
 - Protection level display will show "P".
 - Pre-programmed number 01,77,80,81,82,83,86,91,94,95 & 97 will display.
- 2 Obtain a Touchpad that will be used in the installation. The unprogrammed CPU is going to accept and be programmed to the HOUSE CODE of the Wireless Touchpad.

PROCEDURE-*Using the SX-V Hand Held Programmer*

- 1 Open the rear cover of the Touchpad.
- 2 Plug in the programmer cable to the Touchpad programmer socket.
- 3 Turn on the Programmer, the display should show "Hello".
- 4 Press the HOUSE CODE key and then enter the desired House Code (1 to 254).
- 5 Press the ENTER key to program the House Code into the Touchpad.
- 6 Press the READ key to verify proper House Code setting.
- 7 Disconnect the programmer cable from the Touchpad.
- 8 Place the CPU programming switch to the program position.
- 9 Press the BYPASS key on the Touchpad. This will program the CPU with the same House Code as the Touchpad.
 - The protection level display will show "P" and the sensor number display will go blank for a few seconds.

The following three steps verify that the CPU and Touchpad have the same House Code and that sensor number 34 is in the CPU's memory.

- 10 Use the Touchpad to program one sensor number into the CPU memory. Sensor Number 34 is a good one to use since almost every installation will have a delay entry door.
- 11 Press the "STATUS" key and then immediately press "3" then "4".
- 12 Watch the sensor numbers cycle through the display. Sensor 34 should appear along with the pre-programmed sensor numbers. If sensor number 34 does not appear repeat the above step.

PROGRAMMING ADDITIONAL TOUCHPADS

All other WT and HHWT that will be used in the installation must be programmed with the correct House Code. This is the only programming necessary for proper Touchpad operation.

PROCEDURE

Using the SX-V Hand Held Programmer.

- 1 Open the Touchpad battery compartment door to gain access to the programmer socket.
- 2 Plug the programmer cable into the socket.
- 3 Press the HOUSE CODE key on the SX-V Hand Held Programmer and then enter the desired House Code using the numeric keys (1 to 254).
- 4 Press the ENTER key to program the House Code into the Touchpad.
- 5 Press the READ key to verify proper House Code settings.
- 6 Disconnect the cable from the Touchpad.

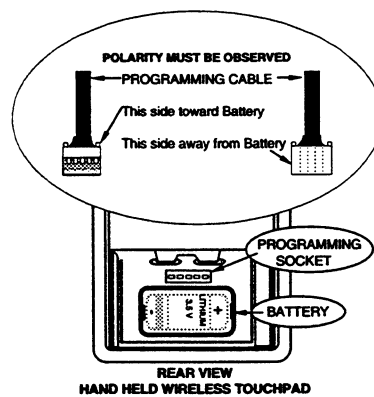

SENSOR PROGRAMMING

This section describes how to program sensors. As discussed earlier, sensors are RF transmitters. They communicate with the CPU which has a built-in radio receiver. In order to successfully communicate:

1. The Sensor frequency must match the frequency of the CPU Receiver.
2. The House Code of the Sensor must match the House Code of the CPU.
3. The Sensor Number assigned to each transmitter (a unique number for every sensor) must be programmed into the CPU memory.
4. Each Sensor must be programmed with its individual sensor number.

VERIFY THE SYSTEM HOUSE CODE

You should have recorded the system House Code on the Central Station Data Card and the CPU Data Card when you first powered up the CPU. Follow these steps if you want to verify the House Code on the CPU display.

- 1 Turn the program switch ON.
- 2 Watch the CPU display until the "H" appears in the protection level display.
- 3 The three-digit House Code will follow in the protection level and sensor display windows.

DETERMINE SENSOR NUMBERS FOR THE INSTALLATION

If you have not yet determined which sensor numbers to use for the installation refer to the Sensor Number Chart and description below before proceeding. Record the sensor number information on the Central Station Data Card and the Customer Data Card (provided at back of manual) to serve as a reference.

PROGRAMMING PROCEDURE

Sensors can be programmed to the desired Sensor Number and House Code using the Hand Held Programmer.

The SX-V Hand Held Programmer allows you to program transmitters before or after they are installed. You can define sensor transmission options for special circumstances. You can put a transmitter to "Sleep". You are also able to "Read" the House Code, Sensor Number, and Sensor Type.

The SX-V Hand Held Programmer is a battery operated device used to program ITI transmitters and Wireless Touchpads. The programmer is used to establish the sensor's HOUSE CODE, SENSOR (zone) NUMBER, and SENSOR TYPE.

- 1 Press the "ON" key of the SX-V Hand Held Programmer. The display will show "HELLO".
- 2 Press the HOUSE CODE key on the SX-V Hand Held Programmer. The 3 House Code digits in the display will flash.
- 3 Enter the desired House Code, a number from 1 to 254. A number outside of the range cannot be entered. The programmer will automatically remove any number that puts the house code out of its range.
- 4 Press the Sensor Number Key on the programmer. The 2 sensor digits in the display will flash.
- 5 Enter the desired Sensor Number. The sensor number you entered will display and flash.
- 6 Press the SENSOR TYPE key on the programmer. The display will flash.
- 7 Select the SENSOR TYPE for the transmitter.

NOTE: Most sensors installed in a system will typically be one of the following types:

<u>SENSOR TYPE</u>	<u>NUMERIC KEY</u>
Door/Window Sensor	1
Motion Sensor	2
Sound Sensor	3
Shock/Glass	4
Carpet Mat/Type Sensor	5
Fixed Panic Sensors	6
Portable Panic Sensors	7
Smoke Sensors	8
Heat Sensors	9
Freeze Sensors	0

- 8 Press the numeric key (0 - 9) which corresponds to the type of sensor you are programming. The individual option LED's for the sensor number you are programming will light. (See SX-V Hand Held Programmer Options.)
- 9 Attach the programming cable to the programmer and the sensor.
- 10 With all the options set, and the programmer cable securely attached, press the ENTER KEY.
- 11 If programming is successful then "donE" is displayed. If FAIL is displayed, check the cable connections and press ENTER again.
- 12 Verify proper programming by pressing the READ key. The display should show the desired House Code, Sensor Number and Sensor Type.

PROGRAMMING ADDITIONAL TRANSMITTERS.

NOTE: To program additional transmitters within the same system, it is not necessary to enter the House Code again.

- 1 Press the SENSOR NUMBER key, then the new sensor number, (0 thru 76).
- 2 If the sensor is a different type, press the SENSOR TYPE key and the new type, (0 thru 9). Set options. (See SX-V Hand Held Programmer Options)
- 3 With the programmer cable connected to the new sensor, press ENTER. If successful, done is displayed.
- 4 Verify your programming by pressing the READ key.

REVIEW SENSOR CHARACTERISTICS TO DETERMINE ANY SPECIAL REQUIREMENTS

The following chart lists sensor numbers and their standard or default programming options which can be changed only by using the SX-V Hand Held Programmer.

Sensor Type	Sensor Number	Supervised	Normally Open	Restore	Motion Lockout	Fire/Panic Priority	Smoke Delay
1 Door/Window	30-47	X		X			
	50-57	X		X			
	70-76	X		X			
2 Motion	60-67	X	X				
3 Sound				X	X	X	
4 Shock/Glass				X	X		
5 Carpet Mat				X	X X	X	
6 Fixed Panic	06-07	X	X		X		
7 Port. Panic	02-05	X	X		X		
	10,11	X see note1	X		X		
8 Smoke	20-27	X	X	X	X	X	
9 Heat				X	X X	X	
0 Freeze	12-17	X	X	X			

NOTE 1: The Portable Panic Transmitter is programmed with the supervisory bit turned on in order to detect a low battery condition in its 9 volt battery. This transmitter is not supervised in the traditional sense as the transmitter can be carried away from the premise.

NOTE 2: While many of the operating characteristics of sensors can be modified with the SX-V Hand Held Programmer, the memory location in the CPU may have to be changed to conform to these modifications. The selection of specific Sensor Numbers for some Sensor Types may require Central Station programming. See Central Station Programming section.

SENSOR TYPE

Six options may be selected in addition to the House Code and sensor number. The SENSOR TYPE key is used to set these options. The options may be turned on or off by pressing the individual option keys with the LEDs. If the LED is 'ON' the option is selected. Press the key once to turn it OFF, once again to turn it back on. A detailed description of the six programmable transmitter options is listed below.

1. SUPERVISED

- If this LED is on, the sensor will transmit a Supervisory signal every 69 minutes.

2. NORMALLY OPEN

- When a transmitter is connected to contacts, such as a reed switch or a push button, this LED should be on only if the contacts are normally separated, and close for an alarm condition.
- If the Transmitter is connected to an electronic output from a sensing device, (PIR, SMOKE etc) this LED should be lit if the output voltage is normally high and goes low for Alarm. If the output voltage is normally low and goes high for alarm, this LED should be OFF. Thus you can interface most equipment that provides a change in a voltage condition to trip an SX-V transmitter.

3. RESTORE

- If this LED is ON, the transmitter sends a Restoral signal when the sensor returns from the violated (alarm) to the normal (restored) condition.

4. LOCKOUT TIMER

- If this LED is on, one alarm transmission is allowed, then further transmissions are prevented until the sensor returns to its restored condition and stays undisturbed for at least 148 to 169 seconds. If the sensor detects motion before this "rest" time is up, the lock out timer is started over again.

5. FIRE/PANIC PRIORITY

- If this LED is on, alarm transmissions are sent more than the usual number of times when an alarm occurs. It is very important to fully understand THE EMERGENCY PRIORITY OPTION FUNCTION before changing the sensor type from the preset condition.
- FCC regulations require that THE EMERGENCY PRIORITY OPTION MUST BE USED ONLY FOR EMERGENCY 24 HOUR SENSORS SUCH AS SMOKE DETECTORS OR PANIC BUTTONS.
- ANY OTHER USE OF THIS OPTION CAN INHIBIT THE PROPER OPERATION OF THE SYSTEM.

6. SMOKE DELAY

- If this LED is on, alarm transmissions will be delayed for about 10 seconds after an alarm occurs. In the case of smoke detectors, this can help prevent false alarms caused by short "CHIRPS" the detectors make when their batteries become low.

PROGRAMMING OPTIONS

ADDING A SENSOR

There are two methods which can be used to add a sensor into the CPU memory.

The simplest method of adding sensors into the CPU memory is to have all the transmitters pre-programmed (House Code, Number, Type) using the SX-V Hand Held Programmer, and simply initialize them into the CPU by activating or tripping the transmitters.

When the CPU is in the program mode and hears a sensor with the proper House Code transmit, it automatically adds the sensor number into the CPU memory.

The second method uses the Wireless Touchpad. Make sure that the CPU program switch is ON.

Press the STATUS button on the Wireless Touchpad. This will momentarily clear the Sensor Number display. Before the display starts to cycle through again, press the TWO DIGITS (i.e.: 05 not 5) on the Wireless Touchpad which make up the sensor number you wish to add. No wait is required before entering the next sensor number, but you must press the STATUS key before each sensor number. (i.e. STATUS + 35; STATUS + 36).

After adding all desired sensors, check the Sensor Number Window to verify all are there.

NOTE: If the Sensor is connected to the CPU using the Special Programming cable at the time you add the sensor using this method, the CPU will program the sensor number into the transmitter as well as its memory. Confirmation is signified by the “bouncing balls”.

DELETING A SENSOR OR PRE-PROGRAMMED SENSOR

- 1 Be sure the program switch is ON.
- 2 Press BYPASS and the two digit sensor number to be deleted. The “bouncing balls” will confirm your actions.

If you delete several sensors, you must push the BYPASS button each time. No wait is required. The “bouncing balls” will display after you stop deleting sensor numbers for about 5 seconds.

- 3 After deleting any sensors, check the Sensor Number Window to be sure they are gone.

NOTE: Entering the wrong number of digits or a number out of the proper range prevents the change from taking effect.

PROGRAMMING CPU OPTIONS

These instructions describe how to program the following information into the memory of the CPU. For many installations only a few of these items will need to be programmed. All of these parameters can be programmed or changed from a Central Station as well.

SENSOR NUMBER of every transmitter

ENTRY DELAY TIME

EXIT DELAY TIME

ACCESS CODE

DURESS CODE

Any OPTIONAL SENSOR NUMBERS 00,77,84,85,87,90,92 or 93.

Any OPTIONAL FEATURE NUMBERS F00 thru F07, F10 thru F17.

CPU ACCOUNT NUMBER

CENTRAL STATION PHONE NUMBER

CPU REAL TIME CLOCK

TO BEGIN PROGRAMMING YOU MUST:

- Be sure the CPU is in Protection Level 0.
- Be sure to use a Wireless Touchpad set to the proper House Code.
- Turn the Program Switch "ON" (up) to select program mode.

The protection level window should show "P". The sensor number window will scroll all preprogrammed numbers and any regular sensor numbers that you programmed previously.

FAST FORWARD PROGRAM VIEWING

If you wish to look at a specific entry in the program while in the program mode, press the fast forward button on the CPU board to quickly advance the program list.

CHANGING ACCESS CODE (preset to 1234)

- 1 Be sure the program switch is ON.
- 2 Press the two AUXILIARY buttons and then the desired four digit access code.
- 3 Wait for the "bouncing balls" to appear in the Sensor Number Window and for an audible beep from the interior sirens. This indicates the data was accepted.
- 4 If the bouncing balls don't appear, try again.

ENTERING DURESS CODE (preset OFF)

- 1 Be sure the program switch is ON.
- 2 Press both POLICE buttons and the desired last two digits of the duress code, and wait for the "bouncing balls". The first two digits are the same as the Access Code set above.

WARNING: Make the last two digits of the Duress Code totally different from ALL DIGITS of the Access Codes.

CHANGING ENTRY DELAY TIME (preset at 32 seconds)

- 1 Be sure the program switch is ON.
- 2 Press both POLICE buttons, then STATUS, and then the two digit entry time in seconds (from 0 to 60) and wait for the “bouncing balls”. The number entered is rounded down to a multiple of four seconds.

For U.L. listed systems, the entry delay shall not exceed 45 seconds.

CHANGING EXIT DELAY TIME (preset at 32 seconds)

- 1 Be sure the program switch is ON.
- 2 Press both POLICE buttons, then BYPASS, and then the two digit exit time in seconds (from 0 to 60) and wait for the “bouncing balls”. The number entered is rounded down to a multiple of four seconds.

CHANGING THE CPU ACCOUNT NUMBER USING A TOUCHPAD (preset to 00-000)

This is the Account Number which reports to the Central Station.

- 1 Be sure the program switch is ON.
- 2 Press both FIRE buttons on the Touchpad and the display should clear. Immediately press the STATUS button, the display should show “CF”. Enter the five-digit Account Number
 - For example, to enter the account number 55-109, you would enter: FIRE + STATUS + 55109.
- 3 The “bouncing balls” and audible indication from connected interior sirens confirm CPU acceptance of your programming. If they do not appear repeat sequence.

PROGRAM THE CENTRAL STATION PHONE NUMBER

This is the Phone Number the CPU will call to report to the Central Station.

- 1 Be sure the program switch is ON.
- 2 Press both FIRE buttons on the Touchpad, immediately followed by the BYPASS key (Display shows “CE”), then up to an eleven digit phone number.
 - For example, to enter the phone number 1-612-555-1212, you would enter: FIRE + BYPASS + 16125551212
- 3 The “bouncing balls” and audible indication confirm CPU acceptance of your programming. If they do not appear, repeat sequence.

PROGRAM THE CPU REAL TIME CLOCK

The CPU clock will be updated automatically for some commands issued from the CS-4000.

- 1 Be sure the program switch is ON.
- 2 Press both AUXILIARY buttons and hold. Listen for 6 beeps (at touchpad), then press the BYPASS key (display shows "C").
- 3 Enter the current time of day, hours then minutes, using "military time" (ie: using a 24 hour clock. Example: 1:00 pm = 1300, 1:00 am = 0100)
 - For example, to enter 6:30 pm, you would enter: AUXILIARY + BYPASS + 1830.
- 4 The "bouncing balls" and audible indication confirm CPU acceptance of your programming. If they do not appear repeat sequence.

SETTING TEMPORARY ACCESS CODE

Your customer can set a Temporary Access Code (for use by baby-sitter, etc.)

- 1 The program switch in the CPU must be in the OFF (down) position.
- 2 Enter the primary access code.
- 3 Press STATUS and immediately enter the desired four-digit Temporary Access Code.
- 4 Wait for the "bouncing balls" to appear in the Sensor number window of the Central Processing Unit and listen for the protection level sound that accompanies the bouncing balls.

NOTE: When not used, program the Temporary Access Code to be the same as the primary access code.

CAUTION!! Do not make the Secondary Access Code similar to the Duress Code!

NOTE: The Secondary Access Code cannot be used to direct bypass sensors.

OPTIONAL SENSOR NUMBERS

The following are OPTIONAL SENSOR NUMBERS. These sensor numbers need to be programmed into the CPU memory if you want their respective features to work. They can also be deleted if a customer decides to have a feature removed from the system.

	SENSOR NUMBER	ACTIVE LEVELS DESCRIPTION
00	0-8	<p>ALARM! BUDDY SYSTEM! If the CPU cannot report a VIOLATION for sensor numbers 02-82, 86 or 92 to the Central Station because it detects a FAIL to COMMUNICATE (preprogrammed sensor #96) or because of NO PHONE LINE (sensor #97), it has a hardwire output that can activate a transmitter programmed to sensor #00. This transmission can be heard by another SX-V CPU which is within receiving range. The CPU which hears the transmission will silently call the Central Station and report "00 ALARM! BUDDY SYSTEM!" and identify itself with the account number of the CPU which experienced the alarm condition. Each SX-V CPU can be programmed to monitor up to 4 other SX-V CPUs within range. This programming can only be done by the Central Station. Non-Alarm reports such as Trouble or Supervisory conditions will not activate this sensor number.</p>
84	0-8	<p>OPENING REPORT USER N. If 84 is initialized, the CPU will report "84 OPENING REPORT" if an arming level is changed and the level being left was a closed level (3,4,5,6 or 7). 84 will clear from the CPU display after successfully reporting to the Central Station. You MUST initialize 85 and you MUST NOT initialize F06 for this feature to work properly.</p> <p>The SX-V CPU can be programmed from the Central Station to understand up to 10 different access codes from 10 different users - when OPENING REPORTS and CLOSING REPORTS are sent to the Central Station the ID Number of the User whose access code armed or disarmed the system will also be reported.</p>
85	0-8	<p>CLOSING REPORT USER N. If 85 is initialized, the CPU will report "85 CLOSING REPORT" if an arming level is changed and the level being entered is a closed level (3,4,5,6 or 7). 85 will clear from the CPU display after successfully reporting to the Central Station. You MUST also initialize 84 and you MUST NOT initialize F06 for this feature to work properly.</p>

SENSOR NUMBER	ACTIVE LEVELS	DESCRIPTION
87	0-8	<p>The SX-V CPU can be programmed from the Central Station to understand up to 10 different access codes from 10 different users - when OPENING REPORTS and CLOSING REPORTS are sent to the Central Station the ID Number of the User whose access code armed or disarmed the system will also be reported.</p> <p>AUTO FORCE ARMED. If 87 is initialized, the CPU will report "87 AUTO FORCE ARMED" whenever the BYPASS button is used to bypass a sensor or gain access to a protection level. The sensor number that was bypassed will also report. 87 will clear from the CPU display after successfully reporting to the Central Station. 87 must be initialized for U.L. installations.</p> <p>The SX-V CPU will automatically force arm whether or not 87 is initialized if the user fails to respond to the "PROTEST" beeps by restoring the open sensor and rearming or by deliberately bypassing the open sensor. If the user leaves the CPU protesting, it will automatically force arm after a pre-determined amount of time. (The length of time is the same as the siren timeout). The CPU will arm to the protection level the user attempted to select and bypass any sensors which were not restored. It will report "87 AUTO FORCE ARMED" to the Central Station.</p>
90	0-8	<p>AC POWER FAILURE. If 90 is initialized, the CPU will report "90 A/C POWER FAILURE" when the AC power to the CPU has been off for 15 minutes. The "Trouble" beeps will annunciate locally. Use this feature only when there is a special need. Remember, if there was a city wide power failure, all systems set to report a 90 A/C POWER FAILURE will report at once. 90 must be initialized for all U.L. installations.</p>
92	4-7	<p>ALARM! TAMPER LOOP. The CPU is shipped with provisions for its door to be connected to a N/C hardwire tamper input. This hardwire tamper input can also have other devices such as the exterior siren tamper or RJ-31X (CA 38A) phone cord tamper connected to it. The tamper loop is N/C. See Optional Feature F01 if you wish to change it to N/O .</p>

SENSOR NUMBER	ACTIVE LEVELS	DESCRIPTION
93	0-8	AUTOMATIC PHONE TEST. If 93 is initialized the CPU will report "93 AUTO PHONE TEST" to the Central Station once every 7 days. The Central Station has the ability to change this time period to report from daily up to once every 255 days. No audible indication is given at the subscribers to indicate this test was sent.

ADDING AN OPTIONAL SENSOR NUMBER

You add an OPTIONAL SENSOR NUMBER just like you would add a regular sensor number:

- 1 First, be sure the program switch is ON.
- 2 Press the STATUS button, then immediately press the optional sensor number desired (00,77,84,85,87,90,92,93).

NOTE: If you add several optional sensors, you must push the STATUS button each time.

- 3 The "bouncing balls" will confirm the CPU's acceptance.

DELETING AN OPTIONAL SENSOR NUMBER

You delete an OPTIONAL SENSOR NUMBER just like you would delete any other sensor number:

- 1 First, be sure the program switch is ON.
- 2 Press the BYPASS button, then immediately press the optional sensor number to be deleted.
- 3 The "bouncing balls" will acknowledge the change.

NOTE: If you delete several optional sensors, you must push the BYPASS button each time.

PRE-PROGRAMMED SENSORS

The following sensors are pre-programmed in the CPU's memory and do not need to be programmed at installation time. You can, however, delete or reinitialize a pre-programmed sensor according to your customer's specific installation requirements.

SENSOR NUMBER	ACTIVE LEVELS	DESCRIPTION
01	0 - 8	BAD SENSOR NUMBER If the CPU hears a transmitter with the correct House Code, but an invalid sensor number for its system program, (i.e., a number not stored in its memory) it silently reports 01 bad sensor number and the number of the invalid sensor to the Central Station. The CPU displays 01 alarm locally. This would determine whether or not the house code you have selected for the installation is available or if an alternative should be chosen.
77	0-8	TOUCHPAD TAMPER If 77 is initialized and the CPU hears 40 Touchpad signals that do not equal the proper access code, plus a protection level, then the sirens will go into audible alarm (Police Siren) (silent in Level 5), and report "77 TOUCHPAD TAMPER" to the Central Station.
80	0 - 8	ALARM FIRE PANIC from a Touchpad. Audible.
81	0 - 8	ALARM POLICE PANIC from a Touchpad. Audible.*
82	0 - 8	ALARM AUXILIARY PANIC from a Touchpad. Audible.* * Sensor numbers 81 and 82 shall not be programmed in U.L. listed systems when the 60-101 touchpad is used.
83	8	PHONE TEST initiated by customer. After a successful test, all sirens sound briefly at the customers home or the Central Station operator should call. In addition, the 83 will clear from the CPU display and the CPU will return to Level 0.
86	0 - 9	ALARM! SILENT DURESS. A specially programmed access code that will send a 24 -hour POLICE EMERGENCY CALL silently to the Central Station. The Duress Code must be followed by any protection level number to activate. This sensor number will not display on the CPU, it will just report. Even though sensor number 86 is pre-programmed, it will not report unless the installer has entered a duress code into the CPU memory.
91	0 - 9	LOW CPU BATTERY After this report is sent to the Central Station (typically 2 to 3 days after AC failure), the CPU is about to shut down until the AC POWER is restored. This shut down prevents deep battery discharge and loss of CPU memory. The memory will be OK for several weeks without AC, however, the battery may need to be replaced. When the AC power is restored, the CPU will re-arm itself to the same protection level that it was in when it powered down. The CPU will report 95 A/C POWER RESTORED when the power comes back on. Up to two back up batteries can be installed in the SX-V CPU. Using two batteries will approximately double the standby time. The CPU could report 91 as

SENSOR NUMBER	ACTIVE LEVELS	DESCRIPTION
		a POWER SUPPLY FAILURE. This condition is usually due to a blown DC Input Fuse, a back-up battery that won't take a charge, or if the power supply has failed.
94	0 - 8	RECEIVER TROUBLE The CPU will report "94 RECEIVER TROUBLE" if it <u>does not hear from any</u> transmitter for 2 hours.
95	0 - 8	CPU BACK IN SERVICE This signal is sent after the CPU has gone into its battery saver shut down routine, which is designed to prevent deep battery discharge and CPU memory loss. The 95 signal is sent when the AC power has been restored and the CPU is BACK IN SERVICE. The CPU will come back on armed to the same protection level it was in when it shut down.
96	0 - 8	FAIL TO COMMUNICATE The CPU makes 3 attempts to contact the Central Station. If the CPU can't get through (after 3 attempts) a 96 will be displayed at the CPU and a trouble tone will sound every 60 seconds. The tone can be silenced by entering the ACCESS CODE + 0. If the CPU is armed to level 5 (silent) and it was trying to report an alarm, then it will sound the police siren. If the customer has elected not to connect to the Central Station then 96 will not exist, as it is only added to the program by the Central Station operator when the hookup is first made. This alarm gives a local indication only. The control unit will continue to make a total of 8 attempts to reach the central station in any of the PMODES programmed.
97	0 - 8	NO PHONE LINE. If 97 is initialized the CPU will check the phone line before attempting any communication with the Central Station. If the phone line is not operational a 97 alarm is initialized, and will be displayed at the CPU. A Trouble tone will sound. The tone can be silenced by entering the ACCESS CODE + 0. If the CPU is armed to Level 5 (silent) and the CPU was trying to report an alarm signal then it will sound the police siren immediately. This is a local indication only.

OPTIONAL FEATURE NUMBERS

The following OPTIONAL FEATURES can also be programmed into the CPU memory. They can also be added from the model CS-4000 Central Station as the other sensors can. All optional features power up "OFF" and must be programmed into the CPU to be "ON".

FEATURE	DESCRIPTION
F00 - EXIT DELAY SOUNDS	OFF - Exit delay beeps will sound only once at the beginning of the exit delay. ON - Exit delay beeps will sound continuously throughout the exit delay time. RECOMMENDATION - Set to OFF under normal circumstances.

FEATURE	DESCRIPTION
F01 - TAMPER POLARITY	<p>OFF - The Tamper input to the CPU is Normally Closed and opens on alarm.</p> <p>ON - The Tamper input to the CPU is Normally Open.</p> <p>RECOMMENDATION - Off under normal circumstances as most tamper inputs will be N/C. Set on if you are connecting a N/O Hardwire input to these terminals.</p>
F02 - EXTERIOR SIREN DELAY	<p>OFF - Exterior Sirens will activate at the same time as Interior Sirens.</p> <p>ON - Exterior Sirens will be delayed for 15 seconds before sounding.</p> <p>RECOMMENDATIONS - By turning this feature on, exterior sirens will be delayed and neighbors will not be aware of some accidental alarms. For highest security, leave it off.</p>
F03 - LOCAL ALARM	<p>OFF - System WILL dial the Central Station.</p> <p>ON - System will NOT report to the Central Station. The CPU should NOT be wired to the phone lines if F03 is set.</p> <p>RECOMMENDATION - Set ON if system is to be local non-reporting system. In U.L. applications, the dialer must be installed.</p>
F04 - LOW BATTERY REPORT	<p>OFF - Low batteries will report when detected LOW and then weekly until replaced.</p> <p>ON - Low batteries will report to the Central Station ONLY upon first detection and never again.</p> <p>RECOMMENDATION - We recommend that this feature be set off so low batteries will report weekly.</p>
F05 - SUPERVISORY REPORT	<p>OFF - Supervisories will report DAILY until repaired.</p> <p>ON - Supervisories will report WEEKLY until repaired.</p> <p>RECOMMENDATION - We recommend that this feature be set off so supervisories will re-report daily.</p>
F06 - DIALER ABORT	<p>OFF - System will report ALARM! and CANCEL even if a customer cancels an alarm within the first 15-20 seconds.</p> <p>ON - System will automatically abort the call to the central station if the customer disarms within 15-20 seconds of accidentally tripping the system. (Except for Smoke and Panic Alarms)</p>

FEATURE	DESCRIPTION
F07 - OPEN SENSOR DISPLAY	<p>RECOMMENDATION - To reduce unnecessary Central Station traffic we recommend this feature ALWAYS BE ON, unless Openings and Closings (84 + 85) have been selected then this feature MUST NOT be set.</p> <p>OFF - Open sensors are not displayed at the CPU when it is armed to protection level 0,1 or 2.</p> <p>ON - Sensors not armed in protection levels 0,1 or 2, which are open will display on the CPU. No condition LED's will be lit.</p>
F10 - DEALER SENSOR TEST	<p>OFF - The standard Level 9 Sensor Test is performed.</p> <p>ON - The CPU will cause Interior Sirens to beep up to 16 times as each data round is received. This feature must be turned on every time you want to hear the data rounds as it turns off as the arming level is changed.</p> <p>RECOMMENDATION - See the section of this manual called TESTING YOUR WORK, DEALER SENSOR TEST for details.</p>
F11 - INTERIOR SIREN SOUND	<p>OFF - The Hardwire Interior sirens will sound Status and Alarm sounds.</p> <p>ON - The Hardwire Interior Sirens will Sound Alarm Sounds only - not Status sounds.</p> <p>RECOMMENDATION - The location of the Hardwire Interior Siren will determine whether or not to turn this feature on. A siren located in a sleeping area, for example, typically would sound alarm sounds but not status to minimize disturbances.</p> <p>NOTE: If used in a system where the 60-193 touchpad has its siren switch in the "off" position, then F11 shall be programmed to off.</p>
F12 - RESTORAL REPORTING	<p>OFF - Violation signals will not be followed up with a Restored report when the sensor is returned to a non-alarm condition.</p> <p>ON - Violation signals set to the Central Station will be followed by a Restored report when the sensor is returned to the non-alarm state. The report will indicate the time, sensor number, and RESTORED condition.</p> <p>RECOMMENDATION - Leave off for most installations unless the additional information of restoral time is desirable.</p>

FEATURE	DESCRIPTION
F13 -	Not Used.
F14 - HOURLY PHONE TEST	<p>OFF - The CPU will not test the telephone line it is connected to once every hour to see if there is DC current in the line.</p> <p>ON - The CPU will test the telephone line once every hour to see if there is DC current in the line. If the CPU detects a problem with the line it will sound the "trouble" beeps (a single beep every 60 seconds from the Interior Sirens) and display a 97 Alarm on the CPU panel. The trouble beeps can be silenced by changing the arming level. If the phone line is not restored in six hours the trouble beeps will begin again.</p>
<p>NOTICE -When the CPU checks the phone line, it seizes the line for 1/2 second to sample it. If the user is on the phone at the time, a brief "click" will be heard but the line will not be cut off. However, if the line the CPU is connected to is ringing and the CPU checks the line while it is ringing the CPU will answer the call then hang up on it.</p>	
<p>RECOMMENDATION - Typically off unless this is a high security application requiring frequent phone line checks. In most installations adding optional sensor number 93 AUTOMATIC PHONE TEST to test once a day provides adequate security.</p>	
F15 - SENSOR TAMPER	<p>OFF - The CPU will go into alarm and report to the Central Station when it hears a "TAMPER" signal from a sensor - provided the CPU is armed to a protection level in which that sensor number is active. If the CPU is armed to a level that the sensor number is not active, the CPU will remember the "Tamper" signal and "PROTEST" as if sensor is open when the system is armed to a level in which the sensor is active. The report to the Central Station identifies the alarm as a "TAMPER".</p> <p>ON - The CPU will go into alarm and report to the central station as soon as it hears a "TAMPER" signal from a sensor regardless of the protection level the CPU is set to. The only exception is if the CPU is armed to protection level 9 - sensor test or if the sensor is bypassed. The report to the Central Station identifies the alarm as a "TAMPER".</p>
<p>RECOMMENDATION - Set to off except in very high security applications to prevent nuisance alarms.</p>	
F16 - TROUBLE BEEPS	<p>OFF - The system will sound 6 quick trouble beeps once each minute to indicate a trouble condition. These beeps will sound for a supervisory 10 hours after detection, a</p>

FEATURE	DESCRIPTION
F17 - DIRECT BYPASS	<p>low sensor battery 7 days after detection, a low CPU battery, if the CPU is unable to communicate, or if the CPU is left in the program mode.</p> <p>ON - The system will protest only if a sensor is open. It will not protest if there is a trouble condition with the exception of fire sensors. Smoke and heat sensors will operate as if the feature were not set.</p> <p>RECOMMENDATION - Typically set this feature on unless it is a high security application. Setting F16 may avoid customer confusion with the protest beeps.</p> <p>OFF - Sensors which have been "Bypassed" can only be "unbypassed" by changing the CPU arming TOGGLE level.</p> <p>ON - Sensors which are presently "bypassed" can be un-bypassed by entering the access code + bypass + the sensor number. See the section on the Wireless Touchpad and Bypassing for more details.</p> <p>RECOMMENDATION - Leave off for U.L. listed installations.</p>

ADDING OR DELETING AN OPTIONAL FEATURE NUMBER

(All optional feature numbers power up OFF)

- 1 Put the CPU in the program mode.
- 2 Press both AUXILIARY buttons on the Touchpad for one second, then immediately press the STATUS button.
- 3 The letter "F" will appear in the sensor number display.
- 4 Press the desired feature number (from 00 - 17). Wait for the "bouncing balls" to confirm your entry.
- 5 Watch the CPU display to confirm that the feature number has been added to memory.

NOTE: THESE OPTIONAL FEATURES TOGGLE ON AND OFF BY USING THE SAME PROGRAMMING METHOD. REPEAT STEPS 1 THROUGH 5.

CONNECTING THE CPU TO THE CENTRAL STATION

PRELIMINARY STEPS

Due to the variety of Central Station Companies who program and receive the ITI equipment, it is impossible to provide you with specific instructions for connecting to your particular Central Station. Contact the Central Station who monitors your accounts for details. There are, however, certain steps and checks which apply regardless of which monitoring company you choose.

- Use an RJ-31X (CA 38A) analyzer to confirm that the jack is properly wired.
- Verify that the CPU is plugged into the RJ-31X (CA 38A) jack.
- Do not use a headset to attempt to listen to the programming while it is in progress. If you do, the CPU will not program properly.
- Remember DO NOT hang up the telephone until AFTER you put the CPU on line by entering the Access Code and Level 8 (PHONE TEST).
- If your Central Monitoring Station uses the automatic TEST feature, the Central Station Receiver will cause the CPU to activate all of its sirens' tones for a few seconds when the CPU first reaches the Central Station and then again when the operator releases the line during a Phone Test (level 8).
- Under most circumstances programming the account number and telephone numbers takes only a couple of minutes to complete and verify. If you do not receive an acknowledgment call from the Central Station operator within 10 minutes, then either the Central Station missed the call or the call was terminated abnormally. This might tie up your customers phone line indefinitely, so you need to check to be sure the phone line is not still seized. If the line is seized then:
 - 1 Unplug the RJ-31X (CA 38A) phone cord to free the line.
 - 2 Shut off the CPU power switch.
 - 3 Call the Central Station for further instructions.

CENTRAL STATION CONNECTION

The following steps are an example of those you will do to connect to your Central Monitoring Station. As mentioned earlier, there will be slight variations depending upon who does your monitoring.

- 1 Most Central Stations will require that the ITI Central Station Data Card or, its equivalent, be in their possession before final programming.
- 2 Call your Central Monitoring Station, identify yourself and tell the operator you wish to connect a new system.
- 3 Provide the operator with the telephone number that the CPU's RJ-31X (CA 38A) jack is connected to.

- 4 Tell the operator about any unusual requirements to access the telephone network. For example, sometimes you must:
 - Dial “1” or “120” then the number.
 - Dial “8” or “9” to get an outside line.
 - Any pauses needed.
- 5 Inform the operator of any special programming requirements.
- 6 Hang up so the operator can call back on the same line as the CPU and RJ-31X (CA 38A) jack.
- 7 Make sure that the CPU is in the normal operating mode, *NOT* program mode.
- 8 The operator will call you back and have you run a PHONE TEST by arming the system to protection Level 8.
- 9 When you arm to Level 8, the phone will go dead. You should hang up. The Operator will program the CPU for you. The phone line will be reconnected to the house phones when the programming is completed.

The following will be programmed:

- The customer’s central station account number.
 - The central station number(s) the CPU will dial.
 - Any special programming requirements you arranged for with the operator.
- 10 The operator will have assigned an account number, usually 5 digits in length. Write the account number on your copy of the Central Station Data Card and the Customer Data Card.
 - 11 To be sure that the account number and phone number(s) have been correctly programmed, initialize a PHONE TEST (Level 8). You should get acknowledgement of a successful test within 2 - 3 minutes.

CENTRAL STATION RECEIVER PROGRAMMING

Although you can program most of the CPU’s functions using a Wireless Touchpad, the following features and functions are typically programmed or changed from the Central Station.

- 1 **CUSTOMER ACCOUNT NUMBER.**
- 2 **CENTRAL STATION RECEIVER PHONE NUMBER (s)** - one or two numbers can be dialed by an SX-V.
- 3 **PMODE:** There are five phone number PMODES or options to choose from. These can be **programmed or changed only from the Central Station Receiver**, using the PMODE Command.

PMODE 0: In PMODE 0 Only 1 phone number is dialed, the second phone number is not used. The CPU powers up in PMODE 0 and no programming need be done if only 1 phone number is to be dialed.

PMODE 1: In PMODE 1 the second phone number is called only if the CPU fails to get through to the first number. The CPU will make 3 attempts to reach the first number before dialing the second number.

PMODE 2: In PMODE 2 the CPU dials the first number to report all alarms and cancels. The CPU dials the second number to report TROUBLE and SUPERVISORY signals only.

This PMODE would be selected by a company that wants alarm calls to go to their Central Station operators, and trouble & supervisory calls to go to a different receiver in the service department.

PMODE 3: In PMODE 3 the CPU dials the first number to report all alarms and openings and closings. The CPU dials the second number to report everything.

This PMODE would be used by a company who has an ITI receiver and is monitored by someone else. The monitoring service would receive only alarm calls, but the alarm company would receive both a record of alarm calls and all trouble reports and supervisory reports.

PMODE 4: In PMODE 4 the CPU dials the first number to report all alarms. The CPU dials the second number to report everything.

This PMODE would be used by a company who has an ITI receiver and is monitored by someone else. The monitoring service would receive only alarm calls, but the alarm company would receive both a record of alarm calls all troubles, supervisories, and all opening/closing reports.

- 4 **EXPANDING GROUPS** can only be done from the Central Station. For example, the CPU powers up with 16 zones reserved for instant exterior zones. If your job calls for more than 16, the Central Station Operator can use the GROUP command to provide additional exterior instant zones.
- 5 **REPORT TIME** - The time of day that unrepaired trouble or supervisory conditions are reported to the Central Station can be changed from the Central Station. This time is preset to 4 hours upon first powering up the CPU. For example, if you first connected the battery to the CPU at 12 noon, the CPU would report any trouble and supervisories at 12 midnight. The Central Station operator will use the STIME command to change the time.
- 6 **SIREN TIMEOUT** - This is preset to 5 minutes but can be set to anywhere from 1 to 15 minutes by the Central Station Operator using the TIMEOUT Command. U.L. installations require a minimum 4 minute TIMEOUT for burglary, 5 minutes for medical.

7 PROTECTION LEVEL CONTROL - The Central Station operator can control each protection level to determine whether it is:

- Active or disabled entirely.
- Accessible using Hi level Access Codes only.
- Accessible using Hi or Low level Access Codes.

For example, in a commercial installation you may want to disable or restrict all arming levels except 0,4, 8 & 9. That way the system can only be completely disarmed (Level 0), armed for maximum protection (Level 4) or tested (levels 8 & 9). The Central Station LEVEL Command is used.

8 MULTIPLE ACCESS CODES - The Central Station operator can program up to 10 Access Codes, in addition to the primary Access Code, into the CPU. Each of these Access Codes can be defined as Hi or Low privileged using the MACCESS command. If a code is Low privileged, only certain protection levels will be accessible. (See Protection Level Control).

CODE	DESCRIPTION	PROGRAM FROM	PRIVILEGE STATUS
0	Primary Access Code	CS, or WT	Always Hi
2	Alternate Primary Access Code	CS only, using MACCESS command	Always Hi
1	Temporary Access Code	CS , using MACCESS command or Touchpad	Always Low
3-10	Multi User Access Codes	CS only, using MACCESS command or Low	Can be defined Hi
11-33	Multi User Access Codes	CS only using XACCESS command	Always Low

9 ALARM! BUDDY SYSTEM! - (Buddy System Programming) The Central Station operator can program the CPU with the Account Number and House Code of up to 4 other CPU's within its receiver range. If one of the other CPU's can't communicate with the Central Station because of an ALARM! BUDDY SYSTEM!, it can trip a transmitter programmed to Sensor Number 00. The "BUDDY" CPU will hear the transmission and relate the House Code to one stored in its memory. It will then report an ALARM! BUDDY SYSTEM! using the account number of the CPU which couldn't communicate.

10 CPU TIME and DATE - The Central Station Operator can program the time of day and day of the year into the CPU. This is to keep track of events as they occur in the CPU event buffer.

11 EVENT BUFFER - The CPU keeps a record of all arming & disarming, alarm, trouble, cancel, and supervisory signals in an event buffer. The last 64 events are stored. The Central Station Operator can review this data using the EVENT COMMAND and can also clear the buffer from the CS.

- 12** AUTOMATIC PHONE TEST - From the Central Station, the operator can program how often the CPU will perform an Automatic Phone Test (optional sensor number 93). This is programmable from once daily to once every 255 days using the PTFREQ Command.
- 13** HOUSE CODE BUFFER - The Central Station operator can review a House Code buffer in the SX-V CPU. This buffer will store any House Code which the CPU has heard other than its own. This is useful in determining the House Code of other systems in range of the CPU. This information can be helpful in determining the House Code of any other systems within range.
- 14** In addition the Central Station operator can change the DURESS CODE, turn options ON or OFF, change ENTRY & EXIT DELAYS etc.

BUDDY TRANSMITTER INTERFACE MODULE

ITI PART #80-064

The Buddy Transmitter Interface Module ensures proper operation of the transmitter by compensating for environmental and installation variables. The Interface Module assures that the Buddy Transmitter will operate under all conditions.

The module contains a circuit which provides a *negative* trip to a Normally Closed Door/Window Sensor input. The circuit is covered with heat shrink for protection and is easy to install.

ATTENTION! All transmitters used for Buddy applications must include this module to assure reliable operation. There are no exceptions. If you need more modules for previously installed Buddy transmitters, contact ITI Tech Services.

Remember when installing Buddy Transmitters:

- SX-Vs can monitor other SX-Vs or RF COMMANDERS.
- RF COMMANDERS *cannot* monitor other SX-Vs or RF COMMANDERS.

INSTALLATION

- 1 Connect RED and BLACK wires to control panel first.
- 2 Secure module to control panel with double sided tape.
- 3 Add necessary wire length to WHITE and BLACK wires so they reach the Buddy Transmitter location.
- 4 Program the transmitter as follows:
 - HOUSE CODE**
 - SX-V:** Same as SX-V panel transmitter is connected to.
 - RF COMMANDER:** Must be different from RF COMMANDER and “listening” SX-V House Codes.
 - SENSOR NUMBER 00**
 - SENSOR TYPE 1**
 - FIRE/PANIC PRIORITY “ON”**
- 5 Press ENTER. Programmer should read. If programmer reads, check programmer cable polarity and try again.
- 6 Initialize sensor number 00 into the “listening” SX-V.
- 7 Set the “listening” SX-V to Level 8 (Phone Test) so the Central Station operator can program it with the Account Number and House Code of the panel the Buddy Transmitter is connected to.

CAUTION! This module is polarity sensitive. Connect as shown or the Buddy Transmitter *will not* function.

RED: Connect to screw terminal #9 on SX-V.

BLACK: Connect to screw terminal #6 on SX-V.

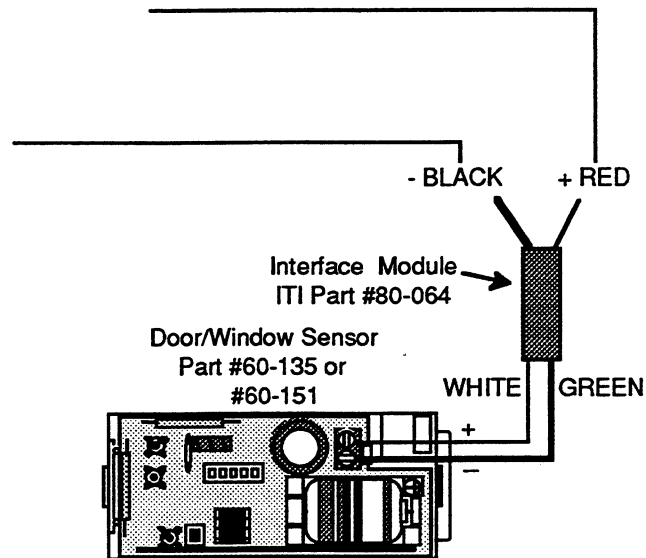

TESTING

- 1 Testing the Buddy Transmitter for transmission range generally takes two people, one at each control panel location.
- 2 Program feature F-10 into the "listening" SX-V.
- 3 Place this SX-V into Sensor Test (Level 9).
- 4 Each time the Buddy Transmitter is activated, the SX-V should respond with a minimum of 12 rounds or beeps. Trip the transmitter several times from one location to verify signal consistency.
- 5 Change the location of the transmitter if the SX-V responds with less than 12 rounds.
- 6 For final test, disconnect the DB-8 cord from the RJ-31X jack at the Buddy Transmitter location. Create an alarm condition at the Buddy sight to trigger the transmitter.
- 7 Contact your Central Station operator to confirm that the "listening" SX-V reported the Buddy alarm.

TESTING

TESTING YOUR WORK CHECKLIST

After all devices are installed and programming is complete, the system should be thoroughly tested.

- Test for proper arming to all protection levels
- Test secondary Access Code
- Test Duress Code
- Test Standby Power
- Test AC Power/Transformer
- Test Bypass Feature
 - Direct
 - Indirect
 - Automatic
- Test Open Sensor Protest
- Test Alarm Memory
- Test Phone connections to CS
- Test any other features you have added.
- Test all Sensors using Sensor Test.
- Test all Sensors using Level 9 Sensor Test.

TESTING YOUR WORK

After all the components of the system are in place, and the CPU has been programmed, the entire system should be checked out using the procedures outlined in this section.

PROTECTION LEVEL TEST / STATUS TEST

- 1 Disconnect the RJ-31X (CA 38A) jack if connected.
- 2 Place each Wireless Touchpad on its mounting bracket. **THIS IS IMPORTANT!**
- 3 Arm to each protection level, 1 to 7. Listen for proper STATUS beeps.
- 4 Push the STATUS button at each level.
- 5 Activate various sensors about the house. Be sure the sensors that are supposed to work at each protection level do work, and the ones that are supposed to be disarmed at each level are disarmed.
- 6 Disarm to Level 0 between each arming, or go directly from one arming level to another.
- 7 Repeat above from every Wireless Touchpad location.
- 8 Select protection Level 0 to end test.
- 9 Reconnect the RJ-31X (CA 38A) plug when test is complete.

TESTING TEMPORARY ACCESS CODE

Following the procedure in the programming section, enter a secondary access code from one of the Touchpads. Try the Temporary access code by arming the CPU to a new protection level to be sure it works properly.

Now, delete the Temporary access code by making it the same as the primary access code. To do this enter the primary access code, push STATUS, then enter the primary access code again.

SENSOR TEST

Sensor Test (Protection Level 9) is used to verify a secure and reliable communications link between the CPU and each of the sensors at the installation site. It also allows testing of the communications between each Wireless Touchpad and the CPU. Additionally, the CPU standby battery is checked since the CPU automatically switches to battery power when Level 9 is selected.

NOTES ABOUT SENSOR TEST

- When the system is set to protection Level 9 it cannot call the Central Station and affords no protection except DURESS calls. Thus, the CPU will automatically go to protection Level 0 fifteen minutes after entering Level 9. This restores basic (fire, panic, etc.) protection.
- Reentering Level 9 (without going to any other level) will reset the 15 minute timer, without changing the display, to give you more test time.
- If Optional Feature F10 is programmed into the CPU, the interior sirens will beep up to 16 times as each data round is received. This feature must be turned on every time you want to hear the data rounds as it turns off when the arming level is changed.

SENSOR TESTING

ACTION	CORRECT RESPONSE
1 Select protection Level 9. (optionally set F10)	All the sensors you programmed, plus pre-programmed sensors 80, 81, & 82 should scroll through the sensor number display. Be sure everything is OK.
2 Activate each door/window sensor	You should hear a loud “beep” (or series of 2-3 beeps for each data round) from all interior sirens as each sensor tests and its sensor number will be removed from the scroll. The sensor number being tested will momentarily display when activated, then it will disappear.
3 Test each Passive Infrared (PIR) at various distances within its pattern.	Listen for the loud “beep” (or series of beeps) as you test each sensor. Remember the PIR needs 3 motion free minutes before each test.
4 Test each Smoke Sensor 2-3 Smoke times.	Press and hold the test button on the Sensor for 20 to 30 seconds until the internal horn sounds and the sensor number is removed from the display.
5 Test each Portable Panic Button from several places.	Point out to your customer any poor reception areas (if any) within the installation.
6 Activate all other sensors in same manner	Listen for the loud “beep” (or series of beeps) as you test each sensor.
7 Activate all the emergency (POLICE) buttons from every touchpad.	Sensor Number 80 (ALARM FIRE PANIC), 81 (ALARM POLICE PANIC), & 82 (ALARM AUXILIARY PANIC) should be removed from the display.
8 Check to see if any numbers still appear on the display	If so, retest these sensors.

DURESS CODE TEST

NOTE: The policy at most Central Stations is to NEVER cancel a Duress Code. Thus, the police will be dispatched whenever a duress code is reported, even if a cancelled report is sent with it. Therefore, be sure to call the Central Station before beginning a Duress Code test.

The DURESS Code will have the same first two digits as the customer's Access Code, the last two digits will be different. The DURESS Code can be entered at any time, in any protection level. Example: Enter code followed by the arming level change.

ACTION

CORRECT RESPONSE

- | ACTION | CORRECT RESPONSE |
|---|---|
| 1 Call Central Station and inform them of the Duress authorize the Duress Code test, Code test by identifying yourself and giving the correct customer account number. Ask the Central Station Operator to call you back when the test comes through. Give the operator the correct phone number. | • Central Station Personnel and repeat correct account number being tested and the phone number of the installation site. |
| 2 Select any protection level by entering the Duress Code rather than the Access Code. | • The interior sirens will sound the appropriate number of beeps for the protection level selected. |
| 3 Enter the customer's ACCESS CODE + 0 from a Touchpad. | • CPU should disarm. |
| 4 Wait for Central Station Operator to call and confirm the receipt of an "86" alarm. | • They should call within two minutes to confirm successful Duress Code test. |

STANDBY POWER TEST

Follow the actions below and verify the correct indications and response to check the standby power.

**ACTION
RESPONSE****CORRECT INDICATIONS /**

- | ACTION
RESPONSE | CORRECT INDICATIONS / |
|--|---|
| 1 Unplug the CPU's transformer. | <ul style="list-style-type: none"> • The CPU display should remain lit. • After a few seconds the power LED will blink. (It glows steady when the CPU has AC power). <p>If the display goes blank immediately then either the CPU battery is dead or disconnected; or the BATTERY FUSE has blown and must be replaced. <u>All memory may be lost.</u></p> |
| 2 Verify that the system using only standby power by selecting 2 or 3 different protection levels. | <ul style="list-style-type: none"> • System responds just as it would if operates operating on AC power. |
| 3 Plug the transformer into outlet and resecure the screw. | <ul style="list-style-type: none"> • After a few seconds the power LED the AC will glow steady again. |

NOTE: The CPU has a power conservation procedure which will shut off the CPU visual displays, except for the power LED, after approximately 15 minutes of drawing from the standby battery. Pressing the Status button will light the display momentarily. An alarm will light the display for approximately 5 minutes.

AC POWER / TRANSFORMER TEST**ACTION****RESPONSE**

- | ACTION | RESPONSE |
|---|---|
| 1 Carefully disconnect the <u>positive</u> battery lead from terminal #5. | <ul style="list-style-type: none"> • Everything should remain the same |
| 2 Verify that the system is working properly. | <ul style="list-style-type: none"> • System responds just as it would if battery were connected. |
| 3 Reconnect the battery lead. | |

INDIRECT BYPASSING TEST**ACTION****CORRECT INDICATIONS / RESPONSE**

- | ACTION | CORRECT INDICATIONS / RESPONSE |
|---|--|
| 1 Select protection Level 0. | <ul style="list-style-type: none"> • CPU protection level display shows "0". |
| 2 Deliberately open any exterior sensor (sensor numbers 34 - 47 , 50 - 57) and note its number. | <ul style="list-style-type: none"> • The sensor is open and remains open. |
| 3 Select protection Level 3. | <ul style="list-style-type: none"> • CPU will not change protection levels (protection level display = "0"). • Interior sirens will produce the "protest" beeping sound. • The number of the open sensor will be displayed.
(NOTE: If more than 1 sensor is violated, the sensor numbers of all violated sensors will be displayed). • All four sensor condition LED's will blink simultaneously. (ALARM, SUPERVISORY, TROUBLE and BYPASS). |
| 4 Select protection Level 0. | <ul style="list-style-type: none"> • "Protest" beeping ceases. |
| 5 Select protection Level 3, then press the BYPASS key.

(ACCESS CODE + 3 + BYPASS) | <ul style="list-style-type: none"> • Interior sirens will indicate the protection level. • The CPU protection level LED reads "3". • The numbers of any sensors which were BYPASSED are displayed and the BYPASS LED lights. |
| 6 Close and open the bypassed or sensors a couple of opened. | <ul style="list-style-type: none"> • The bypassed sensor or sensors do not cause an alarm when closed then times. |

NOTE: With indirect bypassing, you can only bypass sensors such as those on doors or windows which can be left in the alarm condition while attempting to arm the system.

DIRECT BYPASSING TEST

ACTION	CORRECT INDICATIONS / RESPONSE
1 Select protection Level 0.	<ul style="list-style-type: none"> • CPU protection level display shows "0".
2 Select protection Level 3.	<ul style="list-style-type: none"> • CPU will arm to Level 3. The CPU display shows "3" and the sirens sound a group of 3 beeps.
3 Reenter the Access Code + BYPASS + the sensor number you want to bypass. (Choose number which would be active in protection Level 3.)	<ul style="list-style-type: none"> • The CPU display will remain at Level 3. The number of the sensor you bypassed will display and the BYPASS LED will a light.
4 Activate the bypassed sensor a couple of times.	<ul style="list-style-type: none"> • The bypassed sensor does not cause an alarm when tripped.

NOTE: Using direct bypassing you can bypass any sensor number, except smoke detectors.

OPEN SENSOR PROTEST TEST

ACTION	CORRECT INDICATIONS / RESPONSE
1 Select protection Level 0.	<ul style="list-style-type: none"> • CPU protection level display shows "0".
2 Deliberately open one or more exterior sensors. (Sensor numbers 34-47 , 50-57)	<ul style="list-style-type: none"> • The sensor is open and remains open.
3 Select protection Level 3.	<ul style="list-style-type: none"> • CPU does not change protection levels. (Protection level display = 0. • Interior sirens produce the "protest" beeping sound. • The number of the open sensor(s) will be displayed on the CPU. • All four condition LEDs blink simultaneously.
4 While the CPU is protesting close the open sensors.	<ul style="list-style-type: none"> • When all open sensors are closed the protest beeping will stop. • The sensor(s) numbers will clear from the display.
5 Select protection Level 3.	<ul style="list-style-type: none"> • The CPU protection level changes to 3. • The system properly arms to Level 3.

ALARM MEMORY TEST
**ACTION
RESPONSE**
CORRECT INDICATIONS/

-
- | | |
|---|--|
| 1 Select protection Level 3.
(ACCESS CODE + 3) | <ul style="list-style-type: none"> • The CPU protection level display shows “3”. |
| 2 Activate a sensor which is armed in Level 3. Remember this sensor numbers. | <ul style="list-style-type: none"> • Activating the sensor causes the CPU to go into its appropriate alarm sound. • The number of the tripped sensor appears on the CPU display and the Alarm LED lights. |
| 3 Select protection Level 0 to silence the sirens. | <ul style="list-style-type: none"> • The CPU protection level display shows “0”. • The sirens stop. • Be sure to disarm quickly so the Central Station operator will not dispatch the authorities. |
| 4 While watching the CPU display “STATUS” button on a Touchpad. | <ul style="list-style-type: none"> • Interior sirens will sound one long press the beep indicating protection Level 0. • The sensor which was activated will momentarily be displayed when the Alarm LED is lit. |

NOTE: The alarm memory will clear automatically six hours after the protection level is changed. To clear it immediately, arm the system to Level 9.

PHONE TEST

The PHONE TEST verifies a secure and reliable telephone communications link between the customer's CPU and the ITI Central Station Receiver.

ACTION	CORRECT RESPONSE
1 Verify that the phone cord is plugged into the RJ-31X (CA 38A) jack.	• If not, connect it now.
2 Notify the Central Station of your tests.	• Be sure they have a copy of the SX-V CENTRAL STATION DATA CARD.
3 Select protection Level 8. response.	• Listen for correct audible status
4 Observe CPU display.	• Should show protection Level 8. Also, the Sensor Number window should display "83" and the Alarm LED will be lit.
5 Wait 2 minutes for these three indications of a successful communications test.	<p>(a) 83 will clear from the display and the protection level will change to Level 0 when the test is successfully received by the central station receiver.</p> <p>(b) If the test feature is kept on at your Central Station, it will automatically activate the customer's sirens causing them to sound each of their alarm sounds for two seconds each.</p> <p>(c) Central Station will phone you and confirm receipt of test.</p>

CENTRAL STATION DATA CARD

The following describes how each section of the Central Station Data Card should be filled out. It should be completed BEFORE going to the job site. Much of the information that must be put onto the data sheet is self explanatory.

- 1 - ACCOUNT NUMBER - The account number consists of five letters or numbers. The account number is in the form XX-XXX. Many Central Stations use the first 2 characters as the dealer ID and the last 3 as the customer number.
- 2 - CUSTOMER NAME - Put the subscriber's name or the business name here.
- 3 - SPECIAL INSTRUCTION NUMBER - In these spaces, you put the number of any special instructions that appear on the back of the form.
- 4 - CUSTOMER'S PHONE NUMBERS - For residential accounts, enter the home phone, husband's work phone and wife's work phone in these spaces. For commercial accounts you need only enter the business' phone number under "WORK PH#".
- 5 - ACTUAL CITY or LOCATION - In this space, put the actual city, township or parish in which the account is located. This is usually, but not necessarily, the same as the Mailing City.

EXAMPLE 1 - The home is in the town of Cooper, but Cooper has a mailing address of St. Paul. You would enter COOPER, not St. Paul.

EXAMPLE 2 - The home is located in Alamo Township, however the mailing address is Minneapolis. You would enter ALAMO TOWNSHIP.
- 6 - MAILING CITY - Here is where you put the city name the post office wants.
- 7 - POLICE, FIRE, MEDICAL - Enter the exact name of the responding agency and their phone number. Be sure to include the area code for all phone numbers. "911" is not acceptable for emergency phone numbers.
- 8 - KEY? - Circle Y or N depending on whether this person has a key to your subscriber's premise.
- 9 - CONTACTS - Put the name and relationship of the subscriber's contact persons. For Example: Bob Smith (brother-in-law) or Jim Miller (neighbor).
- 10 - NUMBER - Enter the Sensor Number in this column.
- 11 - NOTIFY - Enter who should be notified if this SENSOR NUMBER reports an alarm to the Central Station. Choose only from these words:

POLICE
FIRE
MEDICS

- if Police are to be dispatched
- if Fire Department is to be dispatched
- if Paramedics or Ambulance is to be dispatched
- if Contact Persons ONLY are to be notified. Usually this is for ENVIRONMENTAL zones (furnace failure, water in basement, etc.)

CONTACTS

NOTE: Sometimes you don't want an ambulance or the paramedics dispatched for a medical condition. For example, you simply may want neighbors or relatives called. In this case you could note this with SPECIAL INSTRUCTIONS or you could do this:

CONTACTS Medical Emergency - Call contacts only.

12 - EXACT LOCATION/DESCRIPTION - It is important that you take care and fill out this column in detail. Try to limit yourself to these words to specify the floor level: BASEMENT, 1st FLOOR, MIDDLE FLOOR (for tri-level home), 2nd FLOOR, 3rd FLOOR, ATTIC. Use as few abbreviations as possible. For compass directions use: NORTH, NE, EAST, SE, SOUTH, SW, WEST, NW.

If you are describing a POLICE or FIRE emergency you should indicate the (1) floor level, (2) compass direction and (3) room name, if all are needed to give the exact location. Review the following good and bad examples:

BAD - Master bedroom - painted blue.
GOOD - 2nd Floor, N.E. Corner Bedroom.
COMMENT - A fire department may not be able to tell which bedroom is the master bedroom and customers repaint bedrooms different colors.

BAD - In the Den.
GOOD - 1st Floor, Den, South end of house.
COMMENT - Words like den, library, & family room are too general.

BAD - Smoke Upstairs.
GOOD - Floor 2, Smoke at top of stairway.
COMMENT - Simply stating "smoke upstairs" may not be enough detail. Always indicate the floor level & the specific location on that level.

BAD - Intruder breaking into silver drawer in Buffet.
GOOD - Middle Floor, Dining Room, Buffet silver drawer.
COMMENT - Middle floor is a good term to use if it is the middle floor of a split level or tri-level home. Don't use it otherwise.

IN SPECIFYING DOORS THAT ARE PROTECTED FOLLOW THESE EXAMPLES:

BAD - Front Door.
GOOD - 1st Floor, Front Door, faces Elm Street.
COMMENT - If there were two doors on the front of the house then you would have to be even more specific (1st Floor, Front Door, East Side).

BAD - Garage Door.
GOOD - Door between house and adjoining garage.
COMMENT - "Garage Door" itself might not mean the door from the garage to the house, but instead may mean the service door that leads from the garage to the yard or the overhead door.

If one of the ENVIRONMENTAL zones trips, you usually don't need to specifically locate where the detector is located, you simply note the nature of the problem. For example, the following are all good examples: FURNACE FAILURE, WATER IN BASEMENT, POWER FAILURE TO SUMP PUMP.

13 - SPECIAL INSTRUCTION NUMBER - Enter the numbers of any Special Instructions in these spaces.

14 - SPECIAL INSTRUCTIONS - Enter any special instructions here. See the sample Central Station Data Card that follows for several examples of when and why you might want to specify some special instructions.

15 - SERVICE DATA - Fill out this service information completely.

16 - LOCATIONS - Enter the locations of these devices as well as any HARDWIRE INTERIOR SIRENS and any OUTSIDE SIRENS.

17 -DATA CARD UPDATES - To be completed by Central Station personnel.

CENTRAL STATION DATA CARD

SX-V CENTRAL STATION DATA CARD

Account # _____

NAME: _____
ADDRESS: _____
ACTUAL CITY OR LOCATION: _____
MAILING CITY: _____ ST: _____ ZIP: _____
POLICE: _____
FIRE: _____
MEDICAL: _____
CONTACT 1: _____ Key? Y N
CONTACT 2: _____ Key? Y N
CONTACT 3: _____ Key? Y N
DEALER: _____ Key? Y N

Home Ph # () _____ ()
Work Ph # () _____ ()
Work Ph # () _____ ()
Ph # () _____ ()
Ph # () _____ ()
Ph # () _____ ()
Ph # () _____ ()
Ph # () _____ ()
Ph # () _____ ()
Ph # () _____ ()

Notify dealer: () At time of alarm, or () With Activity Report

NUMBER NOTIFY EXACT LOCATION / DESCRIPTION

Table with 4 columns: NUMBER, NOTIFY, EXACT, LOCATION / DESCRIPTION. Contains 20 rows of empty lines for data entry.

CENTRAL STATION DATA CARD

ACCOUNT # _____

NUMBER	NOTIFY	EXACT	LOCATION / DESCRIPTION
01	-----		CPU TOO CLOSE - System conflict, notify service department..... ()
77	-----		TOUCHPAD TAMPER ()
80	FIRE		MANUAL FIRE EMERGENCY CALL from Customer.....()
81	POLICE		Manual POLICE EMERGENCY CALL from Customer.....()
82	MEDICAL		Manual MEDICAL EMERGENCY CALL from Customer.....()
83	-----		CUSTOMER PHONE TEST..... ()
84	-----		OPENING REPORT.....()
85	-----		CLOSING REPORT.....()
86	POLICE		Silent "UNDER DURESS" CALL FOR POLICE from Customer..... ()
87	-----		FORCED ARMED REPORT (System Armed With Sensor Bypassed) ()
90	-----		A / C POWER FAILURE.....()
91	-----		LOW CPU BATTERY.....()
92	-----		CPU TAMPER ()
93	-----		AUTOMATIC PHONE TEST..... ()
94	-----		RADIO RECEIVER JAMMED OR FAILURE..... ()
95	-----		A / C POWER RESTORED.....()

SPECIAL INSTRUCTIONS FROM FRONT SIDE AND ABOVE

- () _____
- () _____
- () _____
- () _____
- () _____

INSTALLATION DATA:

Freq: _____ Mhz; _____ House Code: _____

CIRCLE OPTIONAL SENSOR NUMBERS SELECTED:

00 77 84 85 86 87 90 93

CIRCLE "F" FEATURES SELECTED:

F00 F01 F02 F03 F04 F05
F06 F09 F10 F11 F12 F13
F14 F15 F16 F17

CROSS OUT ARMING LEVELS DISABLED:

1 2 3 4 5 6 7

CIRCLE PMODE SELECTED:

0 1 2 3 4

LOCATION OF:

- Central Processing Unit _____
- Hardwire Display / Siren _____
- Wireless Touchpad #1 _____
- Wireless Touchpad #2 _____
- Wireless Interior Siren _____
- Wireless Interior Siren _____

GROUP CHANGES:

- | | |
|-------------|-------------|
| GROUP _____ | GROUP _____ |
| GROUP _____ | GROUP _____ |
| GROUP _____ | GROUP _____ |
| GROUP _____ | GROUP _____ |
| GROUP _____ | GROUP _____ |
| GROUP _____ | GROUP _____ |

SENSOR PROGRAM CHANGES:

- Sensor # _____ Type # _____ Changes
- Sensor # _____ Type # _____ Changes
- Sensor # _____ Type # _____ Changes
- Sensor # _____ Type # _____ Changes
- Sensor # _____ Type # _____ Changes
- Sensor # _____ Type # _____ Changes

CUSTOMER DATA CARD

SX-V QUICK REFERENCE GUIDE**HOW TO DISARM**

All burglary protection off.

CODE + 0

HOW TO ARM ONLY THE SPECIAL INTRUSION SENSORS

Protect only special items, cabinets, safes, etc

CODE + 1

CODE + 2

HOW TO ARM YOUR SYSTEM WHILE STAYING INSIDE

Perimeter sensors on, interior sensors off.

CODE + 3

HOW TO ARM YOUR SYSTEM WHEN GOING AWAY

Perimeter and interior sensors on. Full Security.

CODE + 4

HOW TO ARM YOUR SYSTEM AT NIGHT

Perimeter sensors on, select interior sensors on, other interior sensors off.

CODE + 6 (WITH DELAYS)

CODE + 7 (INSTANT)

HOW TO CANCEL AN ACCIDENTAL ALARM

Stop sirens and cancel call to central station

CODE + 0

TEST YOUR SYSTEM OFTEN

It is recommended that you test your system at least once each week. Refer to your SX-V Owners Manual

PROTEST BEEPING SOUND

If you hear protest beeps (beep-beep, beep-beep...) when you attempt to arm your system, either a door or window is open or there is a trouble condition. Check the alarm display. If the sensor is open, close it and rearm. If a trouble condition is shown, fix it and rearm; or, push a trouble condition is shown, fix it and rearm; or, push BYPASS when the protest beeps start sounding

BYPASSING AN OPEN SENSOR

If you wish to arm your system with an open sensor (or if a trouble condition exists), attempt to arm the system, then push the BYPASS button when the protest beeping sound starts.

BYPASSING A PARTICULAR SENSOR NUMBER

First, arm your system, then enter:

CODE + BYPASS + ##

where ## is the sensor number you want to bypass.

STATUS CHECK

To determine the current protection level, push the STATUS button on any touchpad and count the number of beeps from the interior sirens.

ALARM MEMORY

Press STATUS. Any alarms in memory will momentarily scroll through the alarm display.

EMERGENCY ALARM BUTTONS

In an emergency press both POLICE, AUXILIARY or FIRE buttons on any touchpad to sound sirens and notify the proper authorities.

TEMPORARY ACCESS CODE

To enter a second temporary code, enter:

CODE + STATUS + T E M P

where STATUS is the status button and TEMP is the four digit temporary code

SX-V SERVICE RECORD

The SX-V Service Record is on the back side of the SX-V Installation Record Card. The purpose of this form is two fold. First of all it is used to keep a record of the battery change out dates. In addition, the servicing technician has spaces to detail any service performed on the system after the initial installation date.

•• SX-V SERVICE CALL RECORD ••

ALL ALKALINE BATTERIES CHANGED AND SYSTEM COMPLETELY TESTED ON THESE DATES:

(1) ___/___ BY: _____ (5) ___/___ BY: _____ (9) ___/___ BY: _____
 (2) ___/___ BY: _____ (6) ___/___ BY: _____ (10) ___/___ BY: _____
 (3) ___/___ BY: _____ (7) ___/___ BY: _____ (11) ___/___ BY: _____
 (4) ___/___ BY: _____ (8) ___/___ BY: _____ (12) ___/___ BY: _____

SERVICE PERFORMED: Detail below reason for Service Call and corrective action taken.

DATE: ___/___ BY: _____ REASON•ACTION (BE SPECIFIC): _____

 DATE: ___/___ BY: _____ REASON•ACTION (BE SPECIFIC): _____

 DATE: ___/___ BY: _____ REASON•ACTION (BE SPECIFIC): _____

 DATE: ___/___ BY: _____ REASON•ACTION (BE SPECIFIC): _____

 DATE: ___/___ BY: _____ REASON•ACTION (BE SPECIFIC): _____

 DATE: ___/___ BY: _____ REASON•ACTION (BE SPECIFIC): _____

 DATE: ___/___ BY: _____ REASON•ACTION (BE SPECIFIC): _____

 DATE: ___/___ BY: _____ REASON•ACTION (BE SPECIFIC): _____

 DATE: ___/___ BY: _____ REASON•ACTION (BE SPECIFIC): _____

PROTECTION PROVIDED CARD

The small "Protection Provided" card shown here is a completed sample of a card sent with every walnut Wireless Touchpad.

The SX-V has the capability to be armed to eight different levels of protection (0-7). Most homeowners only use three or four of these levels. The purpose of the card is to outline the use of the levels that your customer is going to use, in words that he will understand.

For the first few days, as your customer gets used to the system, he can refer to this card to help him select the proper arming level when he leaves home, when he goes to bed at night, etc.

The card is cut to a very precise size so that it will slip in the back of the walnut Touchpad against the circuit board. This way, whenever your customer has to refer to the card he can simply lift the Touchpad from the mounting bracket, turn it around, and read the information on the "Protection Provided" card.

PLEVEL

PROTECTION PROVIDED

CODE + 0

All burglary protection off.
Fire, Panic, & Auxiliary ON.

CODE + _____

CODE + _____

CODE + _____

CODE + _____

CODE + _____

CODE + _____

Put this card behind Walnut Touchpad

ITI 46-014 (11/91)

2 YEAR LIMITED WARRANTY

SX-V and future equipment manufactured by Interactive Technologies Inc. (ITI) is warranted to be free from defects in material and workmanship for a two (2) year period. The warranty expiration date is indicated by the month and year and/or serial number on the product and should be equal to or greater than two (2) years from the date of purchase. ITI's obligation under this warranty is limited to the repair or replacement of any defective equipment, including parts or components, which become evident, if the product claimed to be defective is returned to ITI at the buyer's expense within the warranty period, along with a written notice explaining the claimed defect in reasonable detail. This Limited Warranty does not cover batteries of any type or parts requiring replacement as a result of normal wear and tear, catastrophe, fault or negligence of user or the wholesale buyer, improper use of the equipment or other causes external to the equipment.

This Limited Warranty extends only to wholesale customers who buy directly from ITI. ITI does not warrant its products to consumers. Consumers or end users should inquire from their selling dealer as to the nature and extent of the dealer's warranty, if any.

Defective units, returned by the buyer at his own expense during the warranty period, will be repaired or replaced at the option of the manufacturer with an equivalent piece of remanufactured and tested equipment. The repaired or replaced equipment is then warranted under the terms of this Limited Warranty for the balance of the term of this Limited Warranty or for ninety (90) days, whichever is longer.

Correction of such defects by repair or replacement of such parts or components shall constitute the fulfillment of all warranty obligations of ITI. ITI shall not be liable for any loss, damages or expenses directly or indirectly arising out of, or in connection with, the use or performance of these products or other indirect damages with respect to loss of property, revenue, or profit, or cost of removal, installation and reinstallation.

THE FOREGOING LIMITED WARRANTY IS IN LIEU OF ALL OTHER WARRANTIES, EXPRESS OR IMPLIED, INCLUDING, BUT NOT LIMITED TO, ANY IMPLIED WARRANTIES OF MERCHANTABILITY OR FITNESS FOR A PARTICULAR PURPOSE. NO PERSON (INCLUDING ANY AGENT, DEALER OR REPRESENTATIVE OF MANUFACTURER) IS AUTHORIZED TO MAKE ANY REPRESENTATION OR WARRANTY CONCERNING THE MANUFACTURER'S PRODUCTS EXCEPT TO REFER PURCHASERS TO THIS LIMITED WARRANTY. FURTHER, ANY IMPLIED WARRANTIES (INCLUDING, WITHOUT LIMITATION, ANY IMPLIED WARRANTIES OF MERCHANTABILITY OR FITNESS FOR A PARTICULAR PURPOSE) ARE LIMITED TO THE DURATION OF THIS LIMITED WARRANTY. SOME STATES DO NOT ALLOW LIMITATIONS ON HOW LONG AN IMPLIED WARRANTY LASTS, SO THIS LIMITATION MAY NOT APPLY TO YOU.

THE PURCHASER'S EXCLUSIVE REMEDY WITH RESPECT TO ANY AND ALL LOSSES OR DAMAGES RESULTING FROM ANY CAUSE WHATSOEVER, SHALL BE REPAIR OR REPLACEMENT, AS SPECIFIED ABOVE. MANUFACTURER SHALL IN NO EVENT, BE LIABLE FOR ANY CONSEQUENTIAL OR INCIDENTAL DAMAGES, HOWEVER OCCASIONED, WHETHER BY NEGLIGENCE OR OTHERWISE. NO SUIT OR ACTION SHALL BE BROUGHT AGAINST MANUFACTURER MORE THAN ONE (1) YEAR AFTER ACCRUAL OF THE CAUSE OF ACTION THEREFOR. SOME STATES DO NOT ALLOW THE EXCLUSION OR LIMITATION OF INCIDENTAL OR CONSEQUENTIAL DAMAGES, SO THIS LIMITATION OR EXCLUSION MAY NOT APPLY TO YOU.



Interactive Technologies Inc., 2266 North Second Street, North St. Paul, MN 55109

MAINTENANCE AND INSPECTIONS

Regularly scheduled maintenance and inspections (at least yearly) are necessary to keep alarm systems in proper working order. Offer a regular maintenance schedule to the system owner and user in addition to advising the user in the system's operation and limitations. Recommendations would include but not be limited to specific guidelines for weekly testing of the system.

The user may not under any circumstances try to service or repair the system; repairs must be done by the factory or an authorized ITI dealer.

ALARM SYSTEM LIMITATIONS

Not even the most advanced alarm system can guarantee protection against burglary or fire. All alarm systems are subject to compromise or failure-to-warn for a variety of reasons:

- If sirens or alarms are not placed within hearing range of persons sleeping or in remote parts of the house. Warning devices may not be heard if they are placed behind doors or other obstacles, or on levels distant from space frequently occupied by residents.
- If intruders gain access through unprotected points of entry, or areas where sensors have been bypassed
- If intruders have the technical means of bypassing, jamming or disconnecting all or part of the system.
- If power to detectors is discontinued or inadequate. Devices will not work if the AC power supply is off and backup batteries are either missing, dead, or improperly installed.
- If smoke does not reach the detector. Smoke detectors cannot detect smoke in chimneys, in walls or roofs, or smoke blocked by a closed door. They may not detect smoke or fire on a level of the building different from the one on which they are located. Sensors may not be able to warn in time about fires started by smoking in bed, explosions, improper storage of flammables, overloaded electrical circuits, or other types of hazardous conditions.
- If transmission lines are out of service. Transmissions from the CPU to a Central Monitoring Station cannot be made over lines that are out of service. Telephone lines are also vulnerable to compromise by any of several means.

Inadequate maintenance is the most common cause of alarm failure. Therefore, the system should be tested at least once per week to be sure sensors, sirens, the communicator, etc. are all working properly.

Although having an alarm system may make the owner eligible for reduced insurance premiums, the system is no substitute for insurance. Warning devices cannot compensate for loss of life or property.

FCC Part 68 Notice

This equipment complies with Part 68 of the FCC rules. On the FCC label affixed to this equipment is the FCC Registration Number and the Ringer Equivalence Number (REN) for this equipment. You must, upon request, provide this information to your telephone company.

The REN is useful to determine the quantity of devices you may connect to your telephone line and still have all those devices ring when the number is called. In most, but not all areas, the sum of the REN's of all the devices connected to the line should not exceed five (5.0). To be certain of the number of devices you may connect to your line, as determined by the REN, you should contact your local telephone company to determine the maximum REN for your calling area.

If your telephone equipment causes harm to the telephone network, the Telephone Company may disconnect your service temporarily. If possible, they will notify you in advance. If the advanced notice is not practical, you will be notified as soon as possible. You will be informed of your rights to file a complaint with the FCC.

Your telephone company may make changes in its facilities, equipment, operations or procedures that could affect the proper operation of your equipment. If they do, you will be notified in advance to give you an opportunity to maintain uninterrupted telephone service.

If you experience trouble with this telephone equipment, please contact:

Interactive Technologies, Inc. 2266 North 2nd Street North St. Paul, MN 55109

(612) 777-2690 for information on obtaining service or repair. The telephone company may ask that you disconnect this equipment from the network until the problem has been corrected or until you are sure that the equipment is not malfunctioning.

This equipment may not be used on coin service provided by the telephone company. Connection to party lines is subject to state tariffs.

IMPORTANT NOTICE FOR CANADIAN INSTALLATIONS

NOTICE: The Canadian Department of Communications label identifies certificated equipment. This certification means that the equipment meets certain telecommunications network protective, operational and safety requirements. The Department does not guarantee the equipment will operate to the user's satisfaction.

Before installing this equipment, users should ensure that it is permissible to be connected to the facilities of the local telecommunications company. The equipment must also be installed using an acceptable method of connection. In some cases, the company's inside wiring associated with a single line individual service may be extended by means of a certified connector assembly (telephone extension cord). The customer should be aware that compliance with the above conditions may not prevent degradation of service in some situations.

Repairs to certified equipment should be made by an authorized Canadian maintenance facility designated by the supplier. Any repairs or alterations made by the user to this equipment; or equipment malfunctions, may give the telecommunications company cause to request the user to disconnect the equipment.

Users should ensure for their own protection that the electrical ground connections of the power utility, telephone lines and internal metallic water pipe system, if present, are connected together. This precaution may be particularly important in rural areas.

Caution: Users should not attempt to make such connections themselves, but should contact the appropriate electrical inspection authority, or electrician, as appropriate.

TELEPHONE PROBLEMS

Should problems develop with the telephone system, unplug the CPU from the RJ-31X (CA 38A) jack. If a problem still exists after disconnecting the CPU, notify the telephone company. If the regular phone works after the CPU has been disconnected from the phone lines, this indicates a problem with the CPU, RJ-31X (CA 38A) jack or your wiring.

If this condition exists;

- Thoroughly check the RJ-31X (CA 38A) wiring.
- With the power switch OFF check terminals 15 and 16 as well as 17 and 18 for continuity with an ohmmeter. These contacts should be SHORTED since the CPU is in a non-dialing condition.

Upon installation of the system, demonstrate disconnection of the phones to your customer.

Disconnecting the phone connection inside the CPU will result in loss of power from the phone lines.

FCC Information

Radio and Television Interference

This equipment has been tested to FCC requirements and has been found acceptable for use. The FCC requires the following statement for your information:

This equipment generates and uses radio frequency energy and if not installed and used properly, that is, in strict accordance with the manufacturer's instructions may cause interference to radio and television reception. It has been type tested and found to comply with the limits for a Class B computing device in accordance with the specifications in Subpart J of Part 15 of FCC Rules, which are designed to provide reasonable protection against such interference in a residential installation. However, there is no guarantee that interference will not occur in a particular installation. If this equipment cause interference to radio or television reception, which can be determined by turning the unit OFF and ON, the user is encouraged to try to correct the interference by one or more of the following measures:

If using an indoor antenna, have a quality outdoor antenna installed.

Reorient the receiving antenna until interference is reduced or eliminated.

Move the receiver away from the control/communicator.

Move the antenna leads away from any wire runs to the control/communicator.

Plug the control/communicator into a different outlet so that it and the receiver are on different branch circuits.

If necessary, the user should consult the dealer or an experienced radio/television technician for additional suggestions. The user might find the following booklet, prepared by the Federal Communications Commission, helpful.

“How to Identify and Resolve Radio-TV Interference Problems”

This booklet is available from the U.S. Government Printing Office, Washington, D.C. 20402. Stock No. 004-000-00345-4.

This device complies with FCC Rules Part 15. Operation is subject to the following two conditions:

1. this device may not cause harmful interference.
 2. This device must accept any interference that may be received, including interference that may cause undesired operation.
- Changes or modifications not expressly approved by Interactive Technologies, Inc. can void the user's authority to operate the equipment.

Telephone Operational Problems

In the event of **telephone operational problems**, disconnect the control/communicator by removing the plug from the RJ-31X (CA 38A) jack. We recommend your certified installer demonstrate disconnecting the phones on installation of the system. Do not disconnect the telephone connection inside the control/communicator. Doing so will result in the loss of your telephone lines. If your regular telephone works correctly after the control/communicator has been disconnected from the telephone lines, the control/communicator has a problem and should be returned for repair.

If, upon disconnection of the control/communicator, there is still a problem on your line, notify the Telephone Company that they have a problem and request prompt repair service. The user may not, in any circumstances (in or out of warranty) attempt any service or repairs on the system. It must be returned to the factory or an authorized service agency for all repairs.

Smoke Detector

ITI Part #60-521 (Canada #60-521-319.5-CN)

OVERVIEW

The System Sensor™ smoke detector is a photoelectronic type detector that contains its own alarm horn and low-battery annunciator. It has an output that trips a special transmitter already built into the detector. An indicator light flashes continuously about 4 times a minute on a normally functioning smoke detector. Two 9-volt alkaline batteries power the smoke detector; both batteries are monitored. The alarm horn in this smoke detector meets or exceeds current audibility requirements of Underwriters Laboratories (UL); however, the horn may not wake up a sound sleeper if a closed door is between the detector and sleeper.

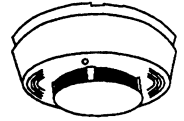

Additional information on Household Fire Warning is available at nominal cost from: The National Fire Protection Association, Batterymarch Park, Quincy, MA 02269. Request NFBA Standard 74.

The System Sensor SX-V Smoke Detector:

- is UL recognized as a system component, listing with the ITI transmitter is pending.
- contains an RF transmitter capable of transmitting at least 1000 feet in open air.
- emits a pulsing tone and its indicator light flashes rapidly during an alarm.
- is powered by two 9-volt alkaline batteries, which last at least 12 months. The approved batteries are Eveready #522 or Duracell #MN1604.
- has its own low-battery annunciator that emits a short "beep" sound every minute if batteries are low.
- monitors smoke detectors and emits a short "beep" every minute if a failure is detected.
- sends a low-battery report (trouble) to the CPU.
- sends a supervisory signal to the CPU every 69 minutes.
- has an operating temperature range of 40° to 100° F.

It is not possible to be specific about Smoke Sensor location since each residence has different design requirements. This smoke detector should be installed in accordance with the National Fire Protection Association, Standard 74 (National Fire Protection Association, Batterymarch Park, Quincy, MA 02269).

INSTALLATION GUIDELINES

DO

- try to keep all smoke detectors within 100 feet of the CPU. The 100-foot distance recommendation is given as a starting guide line. The smoke detector has an open air range of at least 1000 feet, but the installation environment will influence this range.
- determine the best locations for each smoke detector to optimize early detection and maintain accessible escape routes out of the building.
- place a smoke detector at the bottom of the basement stairwells. For stairwells on other levels, place smoke detectors at top of the stairwell.
- mount smoke detectors on ceilings whenever possible and make sure that the smoke detector is no closer than 4" to any wall.
- place the smoke detector no more than 6" from ceiling for wall mounting.
- locate the smoke detector in any hallway servicing bedrooms. For maximum protection, place a smoke detector inside each bedroom, especially smokers' bedrooms or rooms where electric blankets or other electrical devices are used.

DO NOT

- mount smoke detectors in rooms with sloped, peaked, or gabled ceilings whenever possible. If unavoidable, mount detectors 3 feet (0.9 meter) measured horizontally from the highest point of the ceiling. Refer to figure 1.
- mount smoke detector in or near damp or very humid areas such as bathrooms with showers.
- install in areas with excessive metallic surfaces or electrical wiring as these may inhibit the smoke detector's signals from reaching the CPU.
- install near fluorescent light fixtures. Noise from electrical lights may cause nuisance alarms.
- place sensors in location where the temperature exceeds the smoke detector's operating limits of 40° to 100° F.
- mount in very dusty or dirty areas.
- mount near fresh air inlets or returns or excessively drafty areas.
- mount in areas where many insects are present.

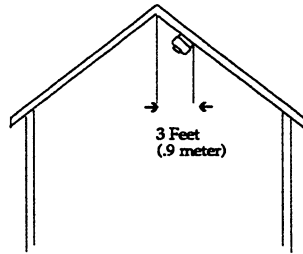

Figure 1. Slope mounting requirements

REMOVING AND REPLACING COVER

To remove the smoke sensor cover to program or service:

1. Remove the smoke detector from the mounting bracket.
2. As you gently unclip the four cover clips with a small screw driver or pen continually push the base away from cover as shown in figure 2.

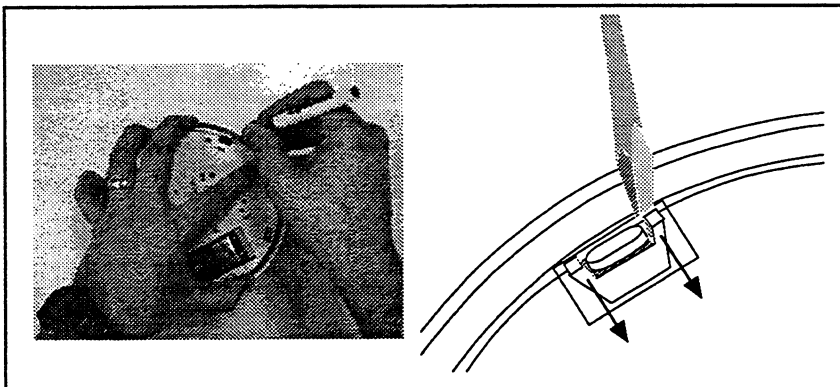

Figure 2. Clip removal

To replace the cover :

1. Line up the test button hole on the cover with the test button on the detector as shown in figure 3.
2. Gently rock the cover back and forth till the light port clears the smoke chamber and the cover seats properly over the detector.
3. Press down on cover until all four cover clips lock into place.

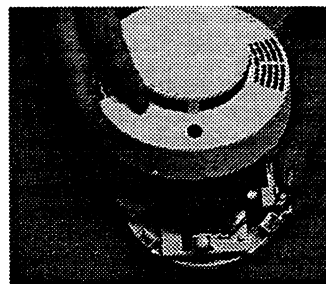

Figure 3. Cover alignment for replacing

PROGRAMMING

The programming cable for this smoke detector must be plugged in with the open face of programming cable facing away from the custom ITI chip, refer to figure 4. With the handheld programmer, program the smoke detector as SENSOR TYPE 8.

SX-V Programming

Typically the sensor numbers for an SX-V system are 20-27. refer to Sensor Programming on page 82.

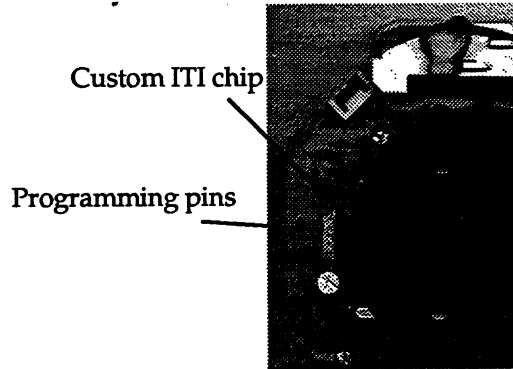

Figure 4. Programming pins and chip location

INSTALLATION

1. Remove the sensor's mounting bracket to screw bracket onto mounting surface.
2. Mount bracket directly onto wood surfaces using No. 8, 1-1/2" wood screws, refer to figure 5. If mounting onto plaster or dry wall, use appropriate anchors.
3. Insert batteries and observe proper polarity.
4. Align the arrows on mounting bracket and smoke detector, and turn smoke detector clockwise till it locks in place, refer to figure 6. Refer to CPU installation manual to program the device into installed CPU.

NOTE: Refer to the appropriate CPU Installation Manual for specific instructions on programming this sensor.

TESTING

We recommend that the smoke detectors be tested on a regular basis, for example, once a week, once a month, etc. Test each sensor to verify that its siren and signal integrity is adequate for continued proper operation of sensor.

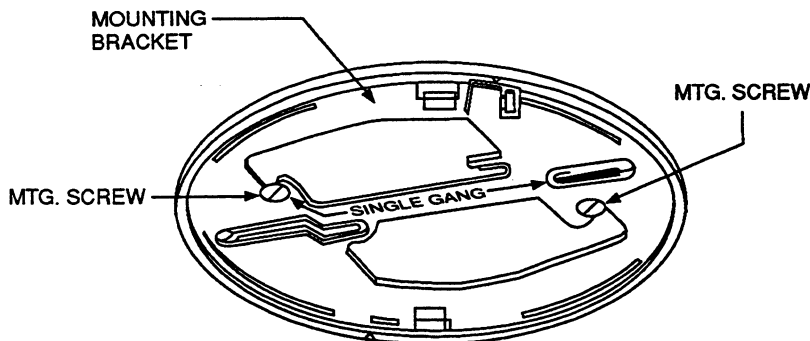

Figure 5. Mounting bracket screw placement

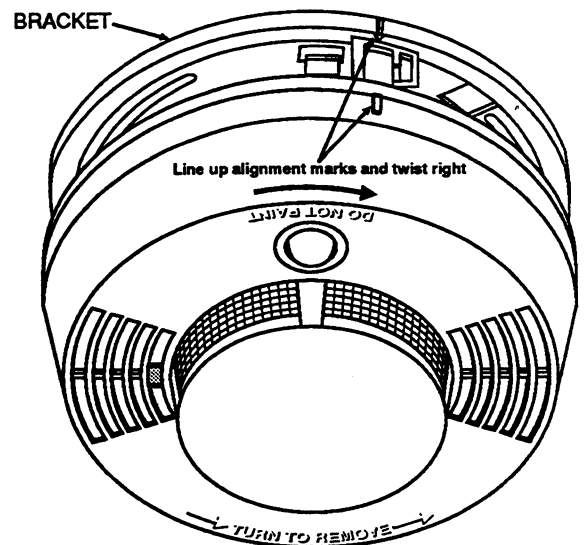
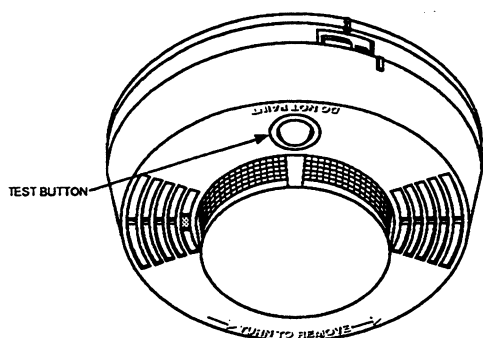

Figure 6. Arrow alignment

1. Initialize sensor test mode on CPU, refer to specific installation manual to initialize sensor test mode.
2. Press and hold the test button on the smoke detector for 20 seconds, then the smoke detector's alarm horn will start and the detector's indicator light flashes rapidly. The device then transmits an alarm signal to the CPU. Refer to figure 7 for test button location.



NOTE: Refer to the appropriate CPU Installation Manual for procedures on performing a dealer sensor test on the entire system.

IMPORTANT! Make sure CPU is in sensor test mode before testing the sensor to avoid a Fire Department dispatch from the central station.

Figure 7. Test button location

OPTIONAL SYSTEM TEST

We suggest testing the smoke detector as part of the security system:

1. Notifying the central station that you will be initiating a fire alarm.
2. Disarm the security system.
3. Trip the alarm by pressing and holding the test button on the smoke detector.
4. Verify that the smoke detector caused the system to go into alarm.
5. Verify with the central station that the alarm signal was received.

CARE AND MAINTENANCE

IMPORTANT! Before cleaning smoke detector the CPU must be placed in sensor test mode.

- Replace batteries one at a time to prevent memory loss.
- Replace batteries once a year, or when the detector emits a low-battery "beep" signal. Use only Eveready #522 or Duracell #MN1604 batteries.
- Carefully vacuum the dust from black meshed area on top of smoke detector at least once a year.

REPLACEMENT PARTS

- Mounting Bracket ITI part number 13-307
- Smoke Detector Cover ITI part number 13-308

SX-V DS-924 (PIR)

ITI Part #60-512

OVERVIEW

A Passive Infrared (PIR) Sensor is designed to detect movement in the interior of a structure. The PIR Sensor detects infrared temperature changes such as that which is emitted from the human body. The coverage area of a PIR sensor is divided into several zones and the PIR senses infrared temperature change in these zones. Any sudden thermal movement across these zones will cause the PIR to send an alarm signal to the CPU.

The DS-924 Motion Detector (PIR)...

- contains an RF transmitter capable of transmitting at least 1000 feet open air.
- is powered by a 3.5 VDC Lithium battery which will last 3 to 4 years.
- sends a supervisory signal to the CPU every 69 minutes.
- has a masking kit to mask portions of the coverage.
- can use different lenses to fit installation requirements.
- has a motion lockout feature. Once the transmitter transmits the lockout feature will not allow the transmitter to transmit again for 3 minutes. The lockout feature is designed to prolong the lithium battery life.
- has a built in walk test feature.
- has an operating temperature of 10° to 120° F.

NOTE: It is important to read the Detection Systems instruction (also included) for proper set up and testing of the PIR.

The following are some guidelines for installation:

DO...

- try to keep all sensors within 100 feet of the CPU. The 100 foot distance recommendation is given as a starting guideline. The DS-924 has an open air range of at least 1000 feet, but the installation environment will influence this range.
- mount the PIR so there is a reference point (such as a wall) at the end of its detection pattern.
- mount the sensor so that an intruder will most likely walk across the detection pattern. Refer to Fig. 1.
- mount the sensor 5 to 8 feet above the floor.
- mount on an outside wall facing in.
- mount on a surface which is rigid and free from vibration.

DON'T...

- mount in direct sunlight. See Figure 2.
- aim at air conditioners, heat vents, wood stoves, fireplaces, intermittent heat source, etc., see Figure 2.
- aim at solar heated walls or non-insulated metal walls.
- aim at moving objects (ceiling fan, pets, etc.), see Figure 2.
- mount the sensor where it can be exposed to moisture.
- place in locations where the temperature will exceed the sensor's operating limits of 10° to 120° F.
- mount in areas with excessive metallic surfaces or electrical wiring as these areas may inhibit the sensor's RF signals from reaching the CPU.
- mount in an area where the coverage may be blocked by any temporary items such as boxes or freight.

Figure 1

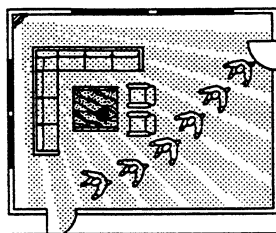

Hot or cold air directed onto sensor



Figure 2

Intermittent heat sources

Direct or reflected sunlight

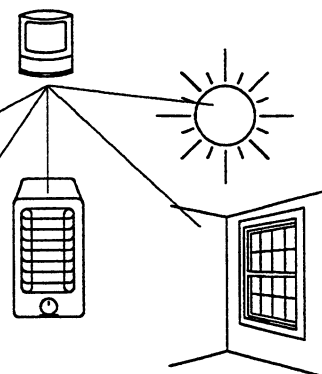

INSTALLATION

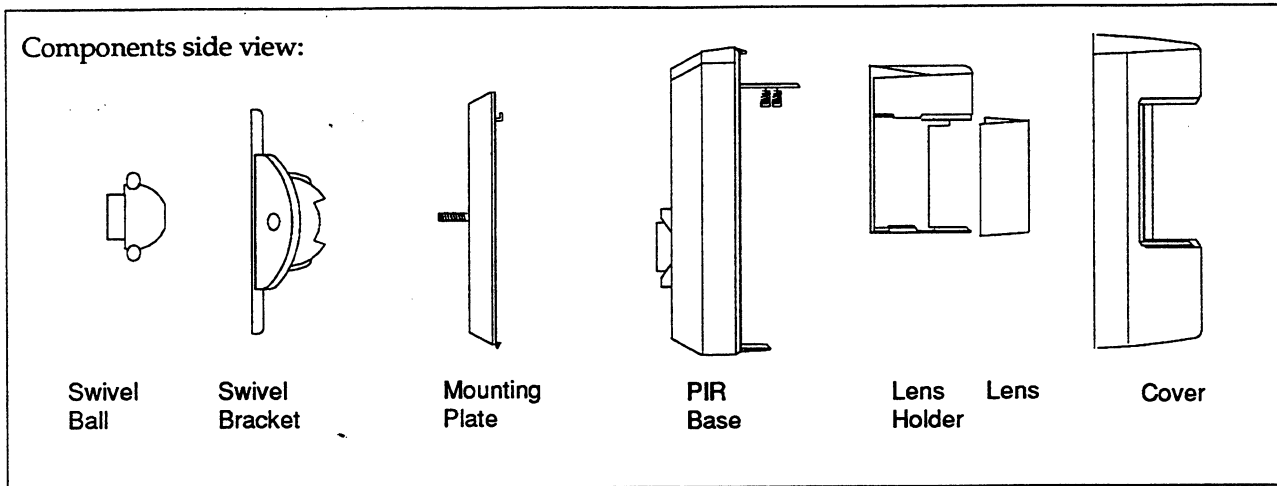

MOUNTING WITHOUT SWIVEL BRACKET

1. Remove Mounting Plate by gently pushing in with your thumb and prying it away from the PIR base (Fig 7), then remove PIR cover as shown in Figure 3.

NOTE: If mounting on dry wall or plaster, we recommend drilling a 1/8 " pilot hole first. This will help determine what material is inside the wall then you can determine if a dry wall anchor or if just the #6 x 1" wood screw should be used.

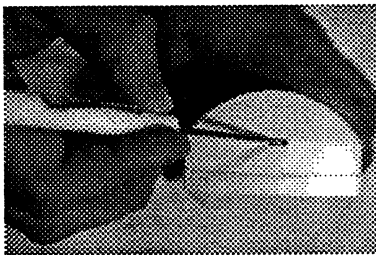

2. Secure the Mounting Plate using either corner mount knock outs or surface mount knock outs according to the installation needs. Refer to figure 4. Use the # 6 x 1" wood screws provided with the PIR.
3. Replace PIR body into Mounting Plate, and secure it to the mounting plate with the Mounting plate screw. Refer to Fig. 8 for screw location.
4. Replace Cover.

Figure 3

Figure 4

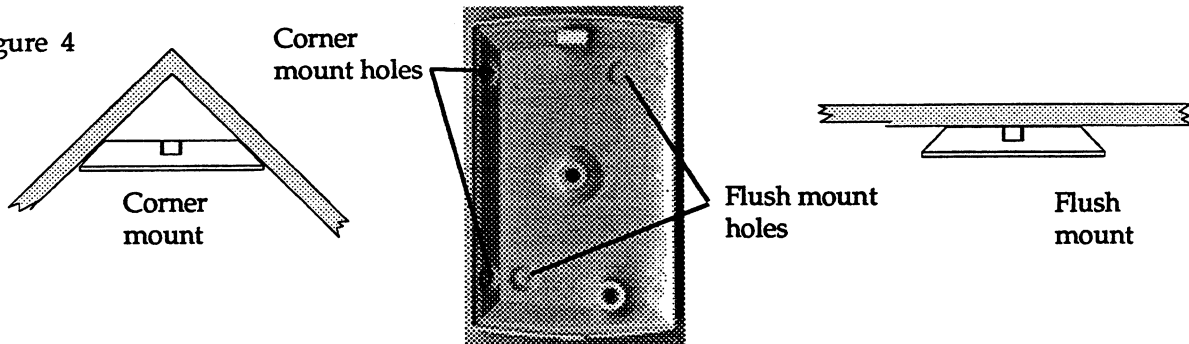

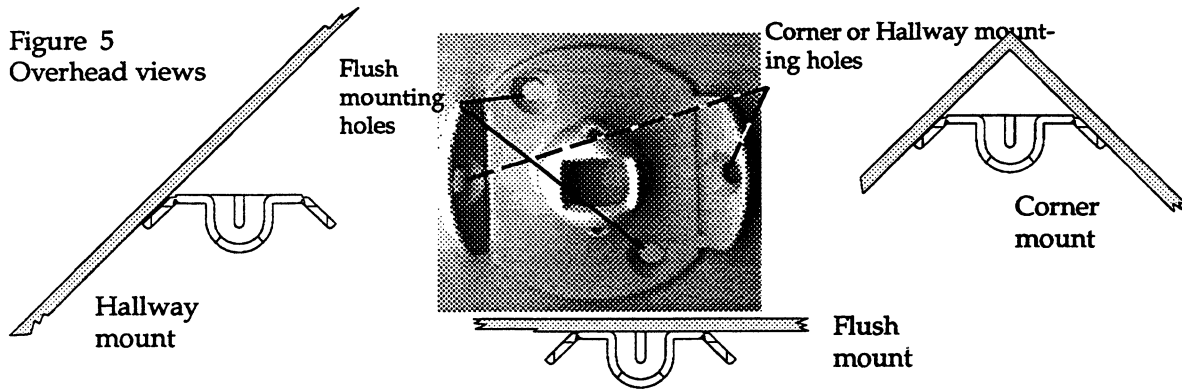

MOUNTING WITH SWIVEL BRACKET

1. Remove Mounting Plate by gently pushing in with your thumb and prying it away from the PIR base.

NOTE: If mounting on dry wall or plaster, we recommend drilling a 1/8 " pilot hole first. This will help determine what material is inside the wall then you can determine if a dry wall anchor or if just the #6 x 1" wood screw should be used.

2. Mount Swivel Bracket with # 6 x 1" wood screw for corner mount, flat surface or flat surface with a hallway orientation. Refer to Fig 5.

Figure 6

Figure 7

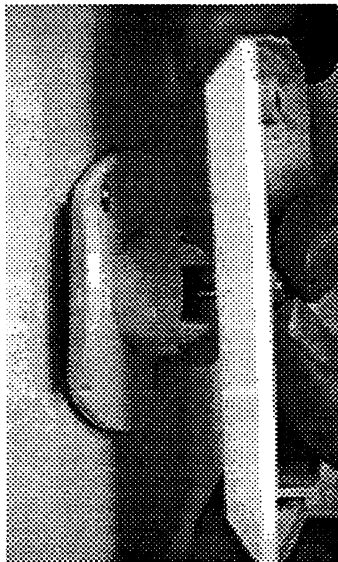

Securing the mounting plate to swivel bracket

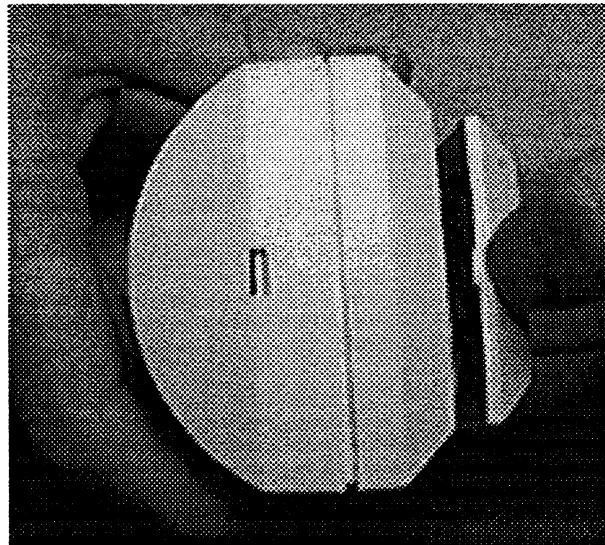

Mounting plate removal

3. Using # 6 x 5/8" metal screw mount Mounting Plate to Swivel Bracket. Tighten until snug Do Not fully tighten screw at this time. Refer to Fig 6.

4. Replace PIR base into Mounting Plate. Check the PIR for correct alignment (refer to Detection Systems instruction for walk test procedure) and when done gently remove PIR base from Mounting Plate and fully tighten metal screw in the Swivel Bracket.

5. Replace PIR base into Mounting Plate, and secure it to the Mounting plate screw. Refer to Figure 8 for screw location.

6. Replace cover.

LENS REPLACEMENT

See the DS924 instructions for details on the different lens coverage and lens replacement. Many lens options are available for the DS924 PIR. If you require a different detection pattern for your application, select the appropriate lens from the DS924 installation instructions. A list of ITI part numbers and associated lens patterns is provided below.

ITI Part No.	Lens Pattern
13-286	Long range Lens
13-287	Pet Alley Lens
13-288	Wide Angle Lens

PROGRAMMING

The programming cable for this PIR must be plugged in backwards (in relation to other ITI sensors) to program correctly.

The open end of the programming cable must face away from the black chip. With the Handheld Programmer, program the PIR as a Motion Sensor, Type 2.

NOTE: The lockout option should not be used on a DS-924 PIR.

SX-V Programming

Typically the sensor number for an SX-V system will be numbers 60-67. Refer to Sensor Programming page 82

WALK TESTING

NOTE: Refer to the Detection Systems installation instructions for specific walk testing procedures.

Figure 8

NOTE: Refer to the CPU installation manual for specific testing procedures.

RF TESTING

General guidelines for performing a Dealer Sensor Test are:

1. Open the cover on the PIR and press the Walk Test switch for approximately 3 seconds. Refer to Figure 8 for switch location.
2. Replace the PIR's cover.
3. Using the appropriate touchpad for the CPU, enter the applicable Dealer Sensor Test code for that CPU.
4. Move across the detection pattern until Walk Test LED turns ON, stop your motion.
5. Note the number of beeps (from the CPU) indicating how much of the RF signal (rounds) from the PIR the CPU heard.

NOTE: On Walk Test you must allow 10 seconds between trips. Walk Test will end automatically once the PIR sees no motion for 90 seconds.



Internal view

GLOSSARY

ACCESS CODES:	2 Primary Access Codes (can select all protection levels), 8 Secondary Access Codes (can select all levels or can be restricted to certain levels), 22 Secondary Access Codes (restricted to certain levels only), 1 Temporary Access Code, and 1 Duress Code. Temporary Access Code, Duress Code and 1 Primary Access Code are field programmable. All codes are Central Station (CS) programmable. Multiple codes identify openings/closing by user.
ACCOUNT NUMBER:	5 digits, can be alpha-numeric; Numeric can be programmed using Touchpad, CS programmable.
AC POWER FAILURE:	Optional feature, Sensor 90, CPU reports AC failure to CS if no AC for 15 minutes, CPU display shuts off after 15 minutes of no AC.
ALARM! BUDDY SYSTEM!	Optional feature, Sensor 00, which allows a nearby CPU to report alarms for a CPU whose phone connection is unusable. Each CPU can "buddy" with up to 4 other CPU's.
ALARM MEMORY:	Alarms which occurred during previous arming period can be reviewed locally; press STATUS, watch CPU display. Memory clears by selecting level 9 or automatically after 6 hours.
ALARM REPORTING:	Sensors report individually to CS. Multiple sensor alarms report in the order they were tripped. Cancel report sent if protection level changed.
APPROVALS:	Equipment manufactured by Interactive Technologies, Inc. has been tested and is in compliance with FCC Rules, Part 15, Subpart J and E and Part 68 where applicable. Each device carries a label giving the specifics and conditions of compliance. This equipment also tested for certain U.L., ULC, DOC, and CSA requirements.
BAD SENSOR NUMBER	If the SX-V hears a transmitter with a matching House Code, but it's a number not in its memory, it display
BATTERY LIFE:	Lithium batteries, 5-8 years; 9 volt Alkaline batteries 12-18 months.
BATTERY TYPE:	CPU - 3.2 amp hour, 6 volt DC Lead Acid, two maximum per CPU. Door/Window Sensors (DWS), Touchpads, 3.6 volt DC lithium. PIR, Smoke, (2) 9 volt alkaline, WIS 9 volt alkaline or rechargeable 9 volt NiCad.
BATTERY MONITORING:	Lithium batteries - not monitored; 9 volt batteries monitored, tested every 69 minutes; CPU battery - monitored, tested weekly.
BATTERY SAVER ROUTINE (CPU):	CPU displays turn off 15 minutes after AC loss. CPU shuts itself off after 2-3 days to save battery & CPU memory. Battery holds CPU memory for days. Powers up in same level as when shut down.

BYPASS SENSORS:	Sensors can be bypassed directly or indirectly using a Touchpad. They are bypassed automatically if the system is "armed" with sensors left open. (Force Armed Auto).
BYPASS TOGGLE:	Optional feature, F17, allows bypassed sensors to be unbypassed by repeating the commands used to direct bypass.
CALL BACK AUTOMATIC	Central feature command that instructs CPU to call back one time after a designated time. (10-2560 minutes one time after a designated time. (10-2560 minutes
CARRIER CURRENT SIGNALING:	Used by CPU to signal WIS (through CPU power transformer terminal 3) over AC power lines. FSK format.
CLOCK, REAL TIME:	CPU real time clock used to assign times for event buffer. Set by CS or installer.
COMMUNICATOR:	Built-in to CPU, Bell 103 format, uses RJ-31X (CA 38A), reports special ITI format. By zone: Alarm, Alarm Cancelled, Supervisory, Trouble Sensor Bypassed, Restorals, Trouble conditions. Pulse dials up to 14 digits, CS programmable. Up to an 11 digit number is Touchpad programmable.
COMMUNICATOR MODES:	<p>Programmed from CS only.</p> <p>PMODE 0 = Dial 1 phone number only - default PMODE</p> <p>PMODE 1 = Dial second phone number only after 3 unsuccessful tries to first phone number.</p> <p>PMODE 2 = Dial first phone number for all alarms and cancels only. Dial second phone number for trouble and supervisory only.</p> <p>PMODE 3 = Dial first phone number for all alarms and cancels only. Dial second phone number for everything.</p> <p>PMODE 4 = Dial first phone number for all alarms except opening/closing. Dial second phone number for everything.</p>
COMPATIBILITY:	SX-V equipment is compatible only with other SX-V equipment. Software 11-30-87 or later is required to operate the Hardwire Buss or the self-programming WIS.
CONTENTION:	Several sensors can transmit to the CPU simultaneously and still be received due to a sophisticated patent pending reporting format.
CRYSTAL CONTROL:	All transmitters and the CPU receiver are crystal controlled to achieve a very narrow bandwidth (25 KHz). This results in a supersensitive receiver.
DELAY TIMES:	Entry/Exit delay times programmable independently from 04 to 60 seconds from Touchpad or CS. Preset to 32 seconds.
DIALER ABORT:	Optional feature, F06, which aborts call to CS if user cancels alarm before dialing to CS is complete. Does not function for FIRE or DURESS calls.

DISPLAY (CPU):	CPU display shows: current protection level, sensor status, CPU power status. Used to review alarm memory. Viewed during programming to check data. Power LED: flashes, when CPU on battery power; steady when CPU on AC; out, when no power to CPU.
DISPLAY DURING FAILURE:	Display shuts off after 15 minutes on standby battery except power LED which flashes. Pressing STATUS momentarily reveals display. Display lights for 5 minutes on alarm.
DISPLAY OPEN SENSOR OPTION:	Optional feature, F07, which causes CPU to display the number of any open sensors in protection levels 0,1,2. No condition LED is lit for open sensors.
DURESS CODE	Programmable by CS or Touchpad. Code used to silently signal the CS of Duress situation. First two digits are the same as Access Code. Duress Code can be entered at any level to activate.
EVENT BUFFER:	64 event history buffer stores date, time, user ID for each event. Stores alarms, trouble, supervisories, bypassing, arming and disarming, and if used open and closing reports. Viewed from CS.
EXTERIOR SIREN:	Exterior siren sounds for police and fire alarms only.
EXTERIOR SIREN DELAY:	Optional feature, F02, which causes a 15 second delay before activating exterior sirens hardwired to the CPU. Exterior sirens hardwired to the WIS can be delayed by setting a dip switch.
EXTERIOR SIREN TIME OUT:	See Siren Time Out.
FAIL TO COMMUNICATE:	Activates if CPU cannot report information to CS. Sounds trouble beeps every 60 seconds locally if CPU is unsuccessful after 3 attempts. Sounds police siren if armed to level 5 and CPU was trying to report an alarm.
FAST FORWARD/ PROGRAM:	Button on CPU which speeds up CPU display in program mode for easier program review.
FORCE ARM:	User can force arm the system with a sensor unrestored using the BYPASS button. Optionally the force arming can be reported to CS.
FORCE ARM AUTO:	CPU will automatically force arm to the level user attempted to select if user attempted to arm with sensor(s) unrestored. Force arming occurs after the programmed time interval for siren time-out. Unrestored sensor(s) will be bypassed. Force Armed Auto is reported to CS.
FREQUENCY:	Crystal controlled for all RF transmitters and matched to CPU Receiver, factory set, not field tunable.
HARDWIRE INPUT/ OUTPUT:	CPU has Hardwire I/O terminals for: Pinpoint Multiplex Module, Hardwire Input Module, Hardwire Touchpad Display, Hardwire Interior Siren, Hardwire Exterior Siren, N/O or N/C tamper circuit.

HARDWIRE BUSS:	A hardwire reporting format or protocol which allows for up to 8 hardwired units to be interfaced to the CPU. Each device is assigned a unit number and is supervised similarly to an RF sensor.
HOUSE CODES:	A programmable electronic password that, combined with the frequency, allows the SX-V and all of its components to communicate. The SX-V has the ability to recognize 255 unique House Codes.
HOUSE CODE BUFFER:	CPU stores all House Codes other than its own. Can be viewed by CS-4000.
MICROPROCESSOR:	The SX-V is microprocessor based.
OPENING/CLOSING	Available as optional sensor numbers 84 and 85, identifies particular user by ID number. (0 - 33)
OPTIONAL FEATURE NUMBERS:	14 Optional features can be programmed to customize the installation
OPTIONAL SENSOR NUMBERS:	7 Optional sensor numbers used to described various trouble, test and convenience options.
PHONE LINE TESTING:	The SX-V can optionally be programmed to test the phone line hourly, F14, and/or before communicating, Sensor 97. It can also be programmed to call the CS at a programmable interval (from daily to 256 days). This feature, Sensor 93, defaults to every 7 days.
PHONE NUMBER CAPABILITY:	Two numbers up to 14 digits long. CS can program pauses between digits. Pauses count as digits. One number up to 11 digits long is Touchpad programmable. See Communicator Modes.
PINPOINT MODULE:	A hardwire buss expansion interface allowing 61 zones of expansion through Identipoint contacts and Dual Point Annunciators (two zones). For more information see PinPoint section.
PROGRAMMER: HAND HELD	The Hand Held Programmer is used to program sensors and Touchpads. It selects sensor type, characteristics and options for each sensor. It can be used to put transmitters to "sleep" and to "read" transmitters.
PROTECTION LEVELS:	8 Arming levels, 2 test levels. Secondary Access Codes can be restricted from certain levels.
RAM TEST:	The SX-V completely tests its RAM memory on power-up. This takes 2 1/2 - 4 minutes. If there is a problem it displays "bad".
RECEIVER:	The CPU contains a crystal controlled superhetrodyne receiver with dual antenna spatial diversity.

RECEIVER FAILURE:	If the CPU hears no signals for 2 hours, it reports 94 RECEIVER TROUBLE to the CS.
SENSORS:	Devices designed to detect a variety of conditions such as open/close status, fire, smoke, freeze, motion etc. and activate a transmitter which will report to the CPU.
SENSOR NUMBERS:	61 installer definable Sensor Numbers (zones) report individually to the CS. 11 pre-programmed sensor numbers describe trouble, test or emergency conditions. 7 Optional sensor numbers describe additional trouble, test and convenience conditions.
SENSOR PROGRAMMING:	A unique number is assigned to each sensor using a Hand Held Programmer. The sensor's number describes its type, (ie Fire, Burglary, Panic) for processing by the CPU.
SENSOR TAMPER:	Switch, integral to the DWS, which causes a tamper signal to transmit when the cover is removed. CPU responds accordingly.
SENSOR TEST:	Protection level 9, allows testing of all sensors with the CPU. CPU will visually and audibly acknowledge successful test.
SILENT ALARM:	Protection level 5 is silent alarm on burglar and auxiliary, becomes audible if cannot report to CS, Fire remains audible.
SIREN DELAY:	Optional feature, F02, which allows 15 second delay before activating exterior sirens directly hardwired to the CPU.
SIREN TIMEOUT:	CS programmable from 1 to 15 minutes, preset to 5 minutes.
SIREN SOUNDS:	Burglary, Fire, Auxiliary, Status, Protest, Trouble, Entry pre-alarm, Exit delay, Chime, Sensor Test indications.
SIREN SOUNDS (HIS):	An Optional CPU feature, F11, controls whether Hardwire Interior Sirens will sound alarms only, or alarm and status sounds.
SIREN SOUNDS	A switch in the WIS controls whether the WIS will produce (WIS): alarm sounds only or alarm and status sounds.
SUPERVISED:	Supervised Sensors report to the CPU every 69 minutes. The CPU looks every 4 hours for sensor reports. If no reports have been received from a sensor the CPU reports the condition immediately to the CS. Trouble beeps will sound locally after 10 hours if the problem is not corrected.
SUPERVISORY PROTESTS:	If a sensor has a Trouble (usually a low battery) or Supervisory condition, the CPU will protest (as if a sensor has been left open) when an attempt is made to arm the system to a protection level in which the sensor is active. You can, however, arm to level 0 without getting the protests. The CPU display will show the problem sensor number and light the appropriate condition LED. If all the LED's are flashing, it means the sensor is open or the tamper switch has been activated. The customer must acknowledge the Supervisory or Trouble condition by arming using the Bypass key. This will not bypass the sensor unless it is open.

- SUPERVISORY PROGRAMMING:** The CPU can be programmed for what time of day to re-report unrepaired supervisories (STIME).
- TAMPER (TOUCHPAD):** Sensor number is programmed which will report to CS if the CPU hears 40 Touchpad keystrokes (8 attempts) which do not equal the access code + a protection level.
- TAMPER (CPU):** The SX-V CPU door can be tampered. The switch is wired N.C. but can be reconfigured for N.O. Other devices could be wired into the same circuit.
- TRANSMITTERS:** Connect to switches or sensors and send RF signals to the CPU.
- TROUBLE:** The SX-V activates Trouble Beeps (6 quick beeps, once each minute) 10 hours after it has detected a Supervisory or 7 days after a Low Battery condition. The Trouble Beeps will also sound when the system has been left in the program mode. The beeps will stop by leaving the program mode, however the Trouble Beeps caused by Supervisories or Low Batteries will re-activate every 10 hours if they have not been corrected. Changing the arming level resets the 10 hour timer.
- UNIT NUMBER:** A unique number to designate the devices connected to the hardwire buss. Supervisories will be reported to CS by unit number.



Interactive Technologies, Inc.
2266 North Second Street
North St. Paul, MN 55109

© 1990 Interactive Technologies, Inc.

46-074

