



A Product of Sentrol, Inc.

INSTRUCTION MANUAL

Part number 10118, REV A

609 SERIES



California State
Fire Marshal
Approved

New York City
Board of Standards
and Appeals
Approved

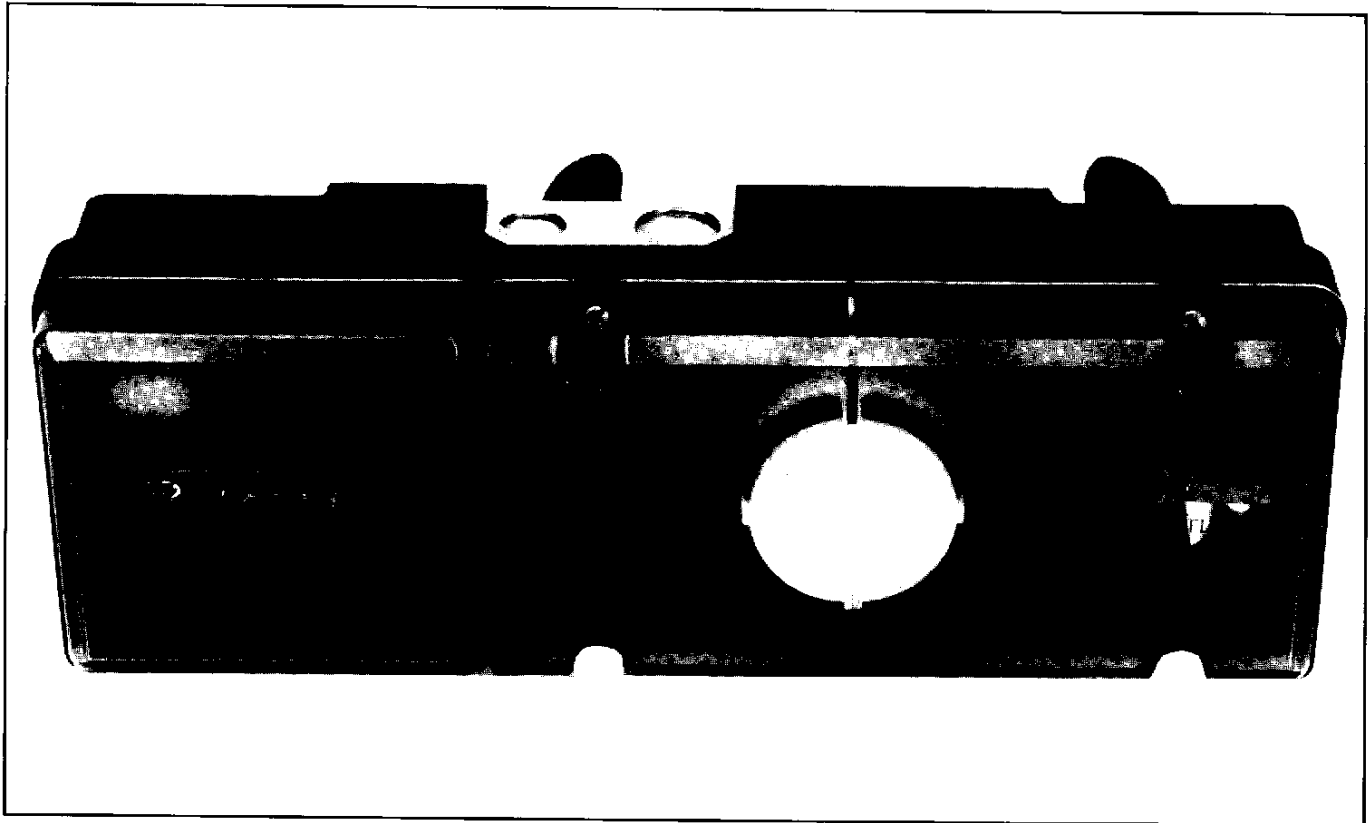

AIR DUCT TYPE SMOKE DETECTORS INSTALLATION AND OPERATING MANUAL

SENTROL, INC.

10831 SW Cascade Blvd. • Portland, OR 97223

Telephone: Sales 1-800-547-2556 • Technical Support 1-800-648-7424

FAX: 503-684-9230

Patent#4.758.827

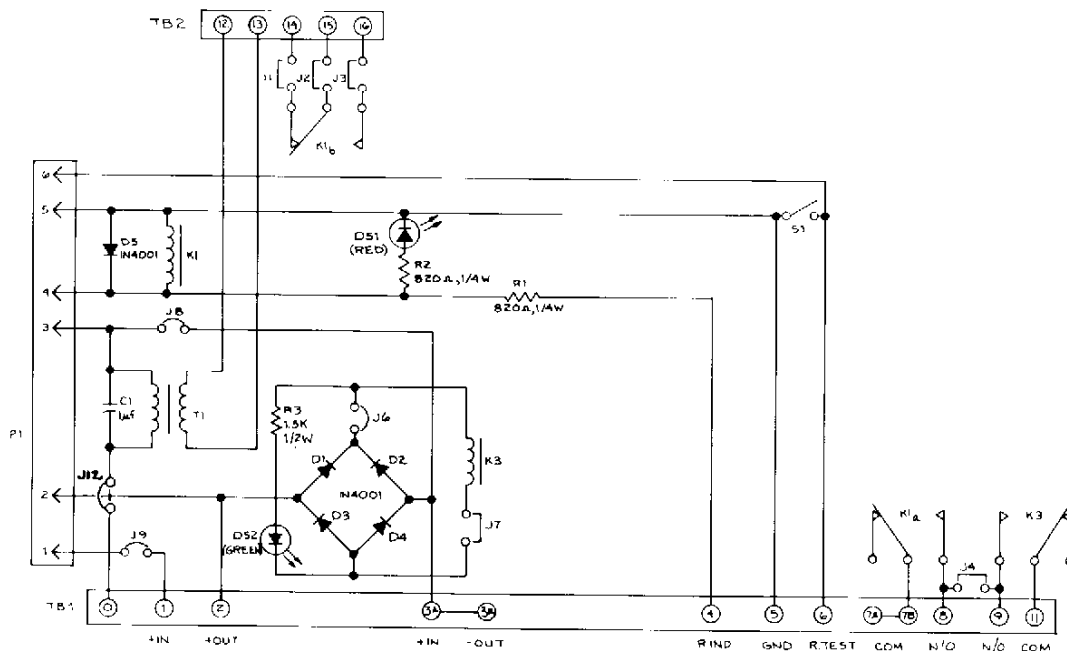

609U23

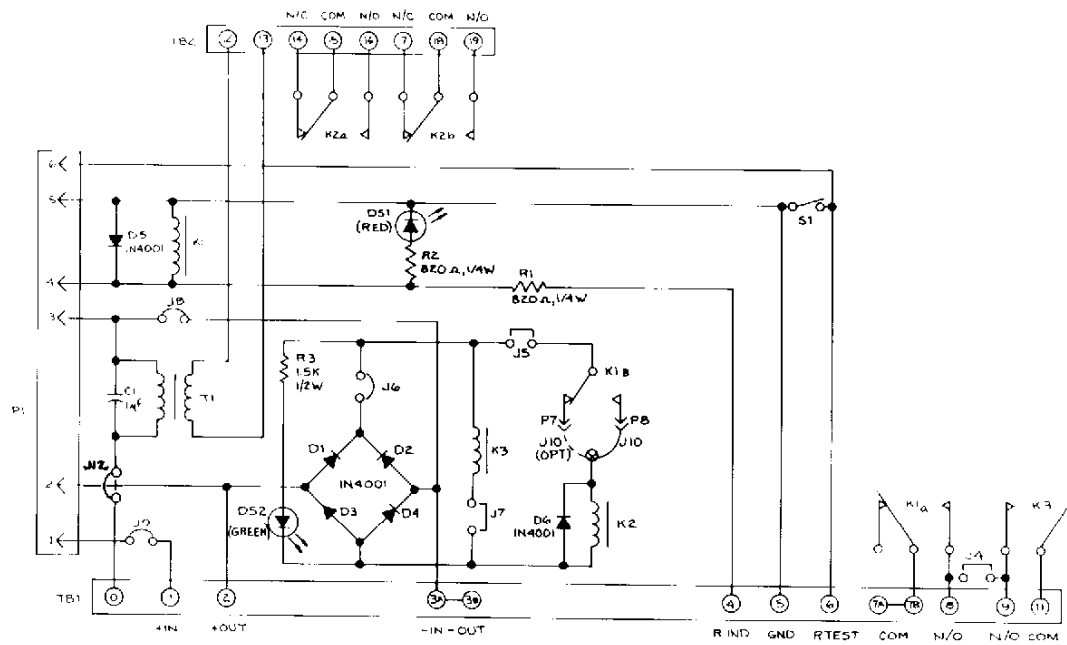

609U24

3.0 APPLICATION

ESL 600 Series fire detectors are suited for commercial, industrial, institutional, and residential fire alarm systems. They are also suitable for stand alone HVAC control. The model 609U00 air duct detector enclosure is an integral part of the 600 Series family of fire detectors and accessories. The interchangeable sensing head configuration allows great flexibility in product application.

The air duct detector is designed for use in air-handling systems with duct air velocities up to 4000 feet per minute. In operation, air is drawn from the duct and passed through the sampling chamber at lower velocity, by means of the integral air sampling tubes. The sample passes through the installed ESL 611UD photoelectronic or 612UD ionization sensing head and is returned back into the duct through the exhaust tube.

3.1 Fire Alarm System Application

Electronic function cards provide for two-wire and four-wire operation for alarm initiation and/or releasing service applications. Two-wire detectors must be connected only to listed compatible initiating circuits. Four-wire function cards for low voltage DC operation, may also be operated from nominal 24 VAC power, commonly available in many HVAC applications.

NOTE: When using two-wire function cards with auxiliary relays, caution must be used when engineering the system to insure

that sufficient power is available from the control panel to operate all detectors on the zone. Otherwise the activation of an auxiliary relay cannot be insured.

3.2 Stand Alone Duct Detector Application

NFPA 90A 198—edition Paragraph 4-5.3 requires audible or visible indication in a normally occupied area to identify air duct trouble condition. Since the intent of this requirement is to provide an alerting signal when the air handling system is operable and cannot be disabled because of detector trouble, control circuit configurations that disable the air handling equipment either upon detector alarm or detector trouble satisfy this requirement.

The detector trouble conditions that require supervision include the installation wiring and the installation wiring connections, the removal of a detector head when separable heads and bases are used, and the availability of power.

The simplest configuration to meet these requirements comprise a normally on pilot light that goes out on the occurrence of loss of power, an open in the installation wiring or the installation wiring connections of the detector, or removal of the detector head from its base. Upon detection of smoke, an audible alarm must sound as long as there is power. The trouble pilot light can either remain on or go out.

4.0 EQUIPMENT

An ESL 600 Series air duct type smoke detector consists of three primary elements: a) the sensing head, b) the selected function card, and c) a housing for the detector and function card. Inlet sampling tube extensions and remote test, remote reset, and alarm indicator equipment may be specified where required.

4.1 Housing for the Detector and Function Card

The base section of the housing that mounts to the duct wall includes: a) integral inlet and exhaust sampling tubes, b) a sensing head mounting base with an automatic-opening continuity switch, c) a conduit connection plate with ground screw, d) the detector cover/manifold assembly with filter and air flow monitor, and e) the function card compartment cover.

The 609U00 is an air duct detector enclosure that accepts a 611UD photoelectronic or 612UD ionization smoke sensing head.

CAUTION: The ESL air duct detector assemblies have been designed for use with ESL Models 611UD and 612UD sensing heads. **DO NOT USE ANY OTHER SENSING HEAD. These are the only sensing heads authorized.**

4.2 Electrical Function Cards

One function card is required for the field wiring connections and is purchased separately and installed in the wiring compartment by a qualified person. Fourteen function cards are Listed by Underwriters Laboratories, Inc.:

VOLTAGE		
LOW WITHOUT POWER-ON	LOW WITH POWER-ON	LINE WITH POWER-ON
609U10	—	—
609U11	609U31	609U21
609U12	609U32	609U22
609U13	609U33	609U23
609U14	609U34	609U24
		609U25

Any of the function cards may be used with the model 609U00 duct detector housing and 611UD or 612UD smoke sensing head. All function cards include a local alarm (red) indicator, local test capability, and provision for remote test and remote alarm indicator connections. All models except 609U10 include a remote detector reset capability. All models with auxiliary alarm contacts are listed as suitable for releasing service applications (see Section 17.0: *Specifications*, page 21).

4.2.1 Two Wire Applications

Three function cards are currently available for two-wire alarm initiating use. Electrical specifications are also given in Section 17.2, Table 1.

All of the cards provide for remote alarm indicator and/or remote test capability, when used in conjunction with the ESL 600 Series accessories: model 606U1 Remote Alarm Indicator or model 606U2 Remote Test and Alarm Indicator. If you require more information call Sentrol, Inc.

The three two-wire function cards are listed below:

- a) The **609U10** function card provides for two-wire alarm initiating capability. The standby voltage range of this card, when

installed in the 609U00 air duct detector housing, is determined by the operating voltage range of the sensing head chosen for the application. The operating voltage range of the 611UD or 612UD sensing head is 8.5 to 44 VDC. Minimum detector alarm current for local alarm indicator operation is 5 milliamperes. The minimum alarm current required for remote indicator operation is 10 milliamperes. Alarm current at 24 VDC is 50 milliamperes ($\pm 10\%$), limited by the detector sensing head. Compatibility identifier is S00.

- b) The **609U11** function card provides for *two-wire* alarm initiating capability with one Form A (NO) and one Form C (SPDT) auxiliary alarm contact set. Form A contacts are rated 2 Amperes @ 30 VDC/120 VAC, Resistive. Form C contacts are rated 2 Amperes @ 30 VDC/120 VAC, Resistive.

The operating voltage range of this card, when installed in a 609U00 air duct detector housing, is determined by the operating voltage range of the sensing head chosen for the application. The minimum alarm current required for alarm indicator and relay operation is 20 milliamperes. Alarm current @ 24 VDC is 50 milliamperes ($\pm 10\%$), limited by the detector sensing head. The compatibility identifier for two-wire operation is S02.

- c) The **609U12** function card provides for *two-wire* alarm initiating capability with one Form A (NO) alarm contact rated 2 Amperes @ 30 VDC/120 VAC, Resistive, and two Form C (DPDT) auxiliary alarm contacts rated 10 Amperes @ 30 VDC/120 VAC, Resistive (5 Amperes @ 220 VAC, Resistive).

The operating voltage range of the 609U12 function card is determined by the sensing head chosen. The minimum alarm voltage required for local alarm indicator and slave relay operation, with or without a remote indicator, is 17 volts. The compatibility identifier for two-wire operation is S36.

When the 609U12 function card is used in a two-wire initiating circuit application, the 10 ampere relay must NOT be programmed for normally operated releasing service. If the relay were programmed in this way, the normal operating current would be increased from 50 microamperes to 10 milliamperes.

4.2.2 Low Voltage, Four Wire Applications

Eight function cards are UL Listed for four-wire alarm initiating and releasing service use, or stand-alone releasing service applications.

All of these cards provide for remote alarm indicator and/or remote test capability when used in conjunction with the ESL 600 Series accessories: model 606U1 Remote Alarm Indicator or model 606U2 Remote Test and Alarm Indicator. All four-wire function cards include an extra terminal to facilitate connection of a remote detector alarm reset switch for use with the ESL Model 609URS Reset Switch or Model 606U3 Remote Alarm Indicator with Remote Test and Reset.

All of these function cards may be powered from a nominal 24 VAC source, available in many HVAC applications. For electrical specifications refer to Section 17.2.

The four function cards are listed below:

- a) The **609U11** function card provides for *four-wire* operation with one Form A (NO) alarm initiating contact, and one Form C (SPDT) auxiliary alarm contact set. Form A contacts are rated 2 Amperes @ 30 VDC/120 VAC, Resistive. Form C contacts are rated 2 Amperes @ 30 VDC/120 VAC, Resistive, and 1 Ampere @ 220 VAC, Resistive.

- b) The **609U12** function card provides for *four-wire* operation with one Form A (NO) initiating alarm contact rated 2 Amperes @ 30 VDC/120 VAC, Resistive, and two Form C (DPDT) auxiliary alarm contacts rated 10 Amperes @ 30 VDC/120 VAC, Resistive (5 Amperes @ 220 VAC, Resistive). (See Section 4.2.6)

- c) The **609U13** function card provides for *four-wire* operation with one Form A(NO) alarm initiating contact and one Form C (SPDT) auxiliary alarm contact set. Form A contacts are rated 2 Amperes @ 30 VDC/120 VAC, Resistive. Form C contacts are rated 2 Amperes @ 30 VDC/120 VAC, Resistive, and 1 Ampere @ 220 VAC, Resistive. A power supervisory (trouble) contact [Form A (NO)] rated 1 Ampere @ 30 VDC/120 VAC, is also provided. Consult the factory for availability of this card. It is only available on a special order basis.

- d) The **609U14** function card provides for *four-wire* operation with one Form A (NO) contact rated 2 Amperes @ 30 VDC/120 VAC, Resistive, and two Form C (DPDT) auxiliary alarm contacts rated 10 Amperes @ 30 VDC/120 VAC (5 Amperes @ 220 VAC, Resistive). A power supervisory (trouble) contact [Form A (NO)], normally closed when the detector sensing head is present and powered, is also provided. This contact is rated 1 Ampere @ 30 VDC/120 VAC. (See Section 4.2.6)

- e) The **609U31** is identical to the 609U11 with the addition of a green Power-On LED indicator.

- f) The **609U32** is identical to the 609U12 with the addition of a green Power-On LED indicator. (See Section 4.2.6)

- g) The **609U33** is identical to the 609U13 with the addition of a green Power-On LED indicator.

- h) The **609U34** is identical to the 609U14 with the addition of a green Power-On LED indicator. (See Section 4.2.6)

4.2.3 Line Voltage, Four Wire Applications

In addition to the standard features discussed in Section 2.0: *Description*, page 3 of this manual, the line-voltage, commercial power function cards include a green Power-On LED indicator that will be lit when the sensing head is in place and powered. All 120 VAC function cards (Models 609U21, 22, 23, 24 and 25) can be field modified by **cutting Jumper J12 for low voltage AC or DC operation.**

All of these cards provide for remote alarm indicator and/or remote test capability when used in conjunction with the ESL 600 Series accessories: model 606U1 Remote Alarm Indicator or model 606U2 Remote Test and Alarm Indicator. All four-wire function cards include an extra terminal to facilitate connection of a remote detector alarm reset switch for use with the ESL Model 609URS Reset Switch or Model 606U3 Remote Alarm Indicator with Remote Test and Reset.

4.2.4 120 VAC Function Cards

The operating voltage of function cards 609U21, 609U22, 609U23 and 609U24 is a nominal 120 VAC (actual min.–max. is 102 to 132 VAC). Standby current is 15 milliamperes. Alarm current is 20 milliamperes.

- a) The **609U21** function card provides for *four-wire* operation with one Form A (NO) alarm initiating contact, and one Form C (SPDT) auxiliary alarm contact set. Form A contacts are rated 2 Amperes @ 30 VDC/120 VAC, Resistive. Form C contacts are rated 2 Amperes @ 30 VDC/120 VAC (1 Ampere @ 220 VAC, Resistive).

- b) The **609U22** function card provides for *four-wire* operation with one Form A (NO) alarm initiating contact set rated 2 Amperes @ 30 VDC/120 VAC, Resistive, and two Form C (DPDT) auxiliary alarm contact sets rated 10 Amperes @ 30 VDC/120 VAC, Resistive (5 Amperes @ 220 VAC, Resistive). Consult the factory for availability of this card. (See Section 4.2.6)
- c) The **609U23** function card provides for *four-wire* operation with one Form A (NO) alarm initiating contact set and one Form C (SPDT) auxiliary alarm contact set. Form A contacts are rated 2 Amperes @ 30 VDC/120 VAC, Resistive. Form C contacts are rated 2 Amperes @ 30 VDC/120 VAC, Resistive (1 Ampere @ 220 VAC, Resistive). A power supervisory (trouble) contact [Form A (NO)] rated 1 Ampere @ 30 VDC/120 VAC, is also provided. Consult the factory for availability of this card. It is only available on a special order basis.
- d) The **609U24** function card provides for *four-wire* alarm operation with one Form A (NO) alarm initiating contact set rated 2 Amperes @ 30 VDC/120 VAC, Resistive, and two Form C (DPDT) auxiliary alarm contact sets rated 10 Amperes @ 30 VDC/120 VAC (5 Amperes @ 220 VAC, Resistive). A power supervisory (trouble) contact [Form A (NO)], normally closed when the detector sensing head is present and powered, is also provided. The contact is rated 1 Ampere @ 30 VDC/120 VAC. (See Section 4.2.6)

4.2.5 220/240 VAC Function Card

The **609U25** function card provides for *four-wire* operation with one Form A (NO) alarm contact set rated 2 Amperes @ 30 VDC/120 VAC, Resistive, and two Form C (DPDT) auxiliary alarm contact sets rated 10 Amperes @ 30 VDC/120 VAC (5 Amperes @ 220 VAC, Resistive).

The operating voltage of function card 609U25 is a nominal 220/240 VAC. Standby current is 5 milliamperes. Alarm current is 10 milliamperes. (See Section 4.2.6)

4.2.6 Field Programming of the 10 Ampere Contacts for Releasing Service

As supplied, the two, 10 Ampere rated, Form C auxiliary contacts provided with function cards 609U12, 609U14, 609U22, 609U24, 609U25, 609U32, and 609U34 transfer on alarm only. The relay that controls these contacts may be field programmed, by moving Jumper J10 from pin P8 to pin P7, to be energized in the normal standby condition, so that the contacts transfer on removal of the sensing head, loss of power to the air duct detector assembly, or alarm of the sensing head. This may be desirable in many releasing service applications.

The Form A alarm contact remains available for signaling an alarm of the smoke sensor. The Form A trouble contact on models 609U14 and 609U24, remains available for signaling a trouble condition.

4.3 Sensing Heads

The 609 Series duct detectors use model 611UD photoelectronic or model 612UD ionization smoke detector heads.

4.4 Sampling Tubes

Each duct detector housing is equipped with 5.25 inch inlet and exhaust sampling tubes. The ends of these tubes are cut at a 45° angle. The inlet tube faces upstream and the exhaust tube faces downstream to ensure airflow through the housing. The tubes provide the means for obtaining a sample of air from the duct. A pressure differential pulls air in through the inlet sampling tube and into the sampling chamber, then sends it back out into the duct through the outlet sampling tube.

When required by the authority having jurisdiction, *optional* inlet sampling tube extensions are available in several lengths. They are fully slotted to maximize air sampling capability. End caps are provided on both ends of the extension tubes for protection during shipment. One is left in place to close the far end of the tube; the other (on the detector housing end) is removed and discarded. The inlet sampling tube extension length is determined by the width of the air duct being protected (see Figure A, page 3).

After mounting the housing to the duct, the tubes are installed by sliding them inside the integral inlet tube, and securing them from the front using the retaining screw in the hardware package.

On ducts over 4 feet wide, it is recommended that the sampling tube extension, *if used*, be extended through, and supported at, the opposite wall of the duct. Use the tube extension whose length is nearest to, but greater than, the duct width. This tube is then trimmed during installation.

This product is approved for use with no extension tubes.

NOTE: In some applications the addition of an optional extension sampling tube, may cause the air flow monitor to stop rotating. This is a result of the lesser air volume sampled by the optional extension tube, mostly attributable to its smaller inside diameter.

4.5 Accessories

Model Number	Description
606U1	Remote indicator
606U2	Remote indicator with keyed remote test
606U3	Remote indicator with keyed remote test and reset
205A	Inlet sampling tube extension—2 ft. (61 cm)
205B	Inlet sampling tube extension—4 ft. (122 cm)
205C	Inlet sampling tube extension—8 ft. (244 cm)
605A3	Test tool
204A	Power supervision unit for 12 VDC systems
910-4	Power supervision unit for 220 VAC systems
609URS	Reset switch, normally closed with 9" leads

4.6 Replacement Parts

Model Number	Description
62001022B	Foam filter
66809084A	Relay — 10 Amp

5.0 APPROVALS

The ESL 609 Series air duct type smoke detectors are for use in commercial fire protective signaling systems (NFPA 71, 72A, 72B, 72C, or 72D), and in commercial air conditioning and ventilating systems (NFPA 90A). Listed by Underwriters Laboratories, Inc.; California State Fire Marshal approved (Listing #3240-447: 120); Factory Mutual approved (J.I.OQ7A1-AY); New York City, Board of Standards and Appeals approved (Calendar No. 122-73-SA); State of Maryland approved (Permit #1905); City of Cleveland approved (Docket S-5-88).

6.0 INSTALLATION

The basic installation procedure is as follows:

1. The 609U00 detector housing is mounted to the exterior of a duct with the provided hardware.
2. Conduit connections are made.
3. Field wiring is dressed into the wiring compartment.
4. The function card is installed and connections completed.
5. The sensing head, air filter, manifold, and covers are installed.

6.1 Installing the Air Duct Smoke Detector Housing (609U00)

6.1.1 Location on the Duct System

1. Locate the air duct type detector in the main supply duct, downstream of the filters. Position it so that it will operate reliably in case of smoke in any part of the air stream. In instances where filters are capable of removing smoke, install a detector both upstream and downstream of the filters.

NOTE: The air duct detectors use sampling tubes which monitor the width of an air duct. Since stratification can occur in the airstream, it is desirable to locate the detector after bends or inlets which create turbulence—and hence, a more homogeneous mixture of air. The detector should, when possible, be located a minimum of six duct widths downstream from the source of the turbulence (see Figure B, page 8). A 12 inch by 12 inch access hole may be cut in the duct adjacent to the detector to permit checking and cleaning of the optional extension sampling tubes, if necessary.

The air duct type detector should be located in the air handling system, as in Figure C, page 8. It should be installed in conformance with NFPA Standard 90A, "Installation of Air Conditioning and Ventilating Systems," and NFPA Standard 72E, "Automatic Fire Detectors." Additional guidance may be obtained by reading the "Guide for Proper Use of Smoke Detectors in Duct Applications" (NEMA).

2. A detector on the return air side of the blower should be located at a point PRIOR to exhausting air from the building or diluting return air with outside air.

NOTE: Remember that detectors will only alarm when combustion particles constitute a specified percentage of the air being sampled. Outside air, if it mixes with circulated air, can dilute combustion particle concentration and prevent a detector from operating properly. To avoid dilution, detectors should be located before fresh air intakes and before the exhaust air output. The detector on the supply side of the blower should be located downstream of the blower.

3. The detectors can be wired into the system so that they automatically shutdown the blowers and operate dampers as required.

4. The following should also be considered:

- a) **Excess Humidity:** As with normal open area detectors, high levels of humidity or condensation within the duct can cause false alarm problems. Duct detectors should be located at least ten feet downstream from humidifiers.
- b) **Air Filters:** Air filters within ducts tend to collect paper, lint, and trash—all flammable materials. For this reason, duct type detectors should be located on the downstream side of filters.
- c) **Air Velocity:** Duct type smoke detectors are usually designed to be used in air handling systems having a certain range of air velocities. Be sure to check engineering specifications to make sure duct air velocity falls within these parameters.

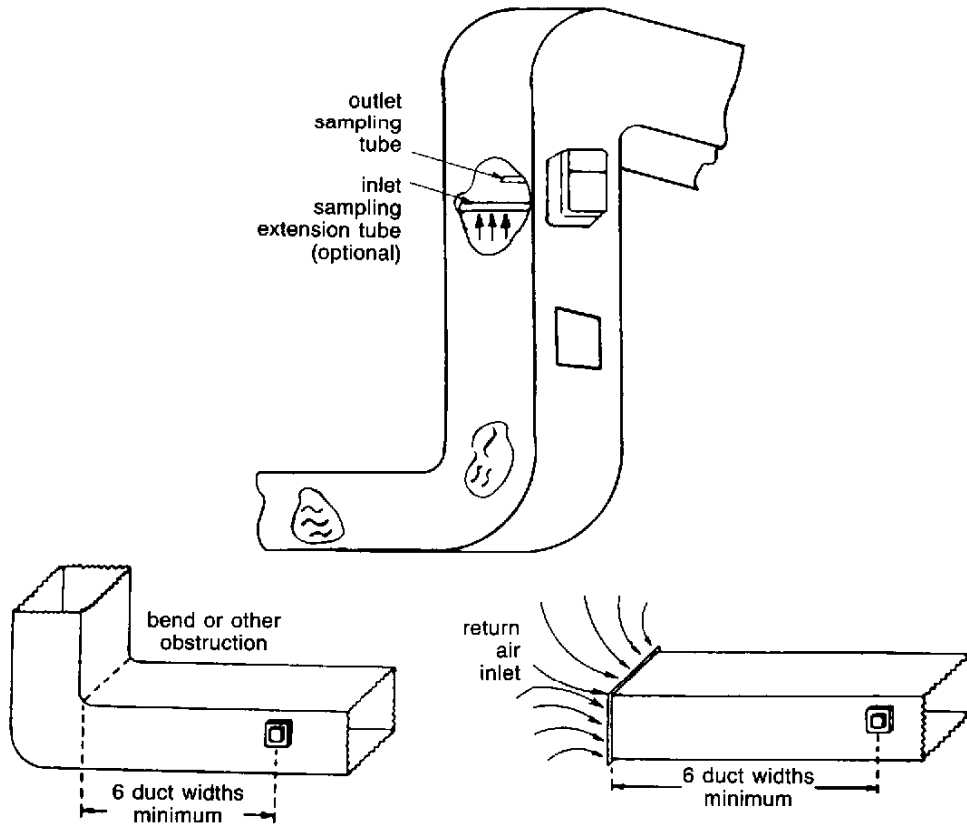

Figure B: Typical Duct Detector Placement

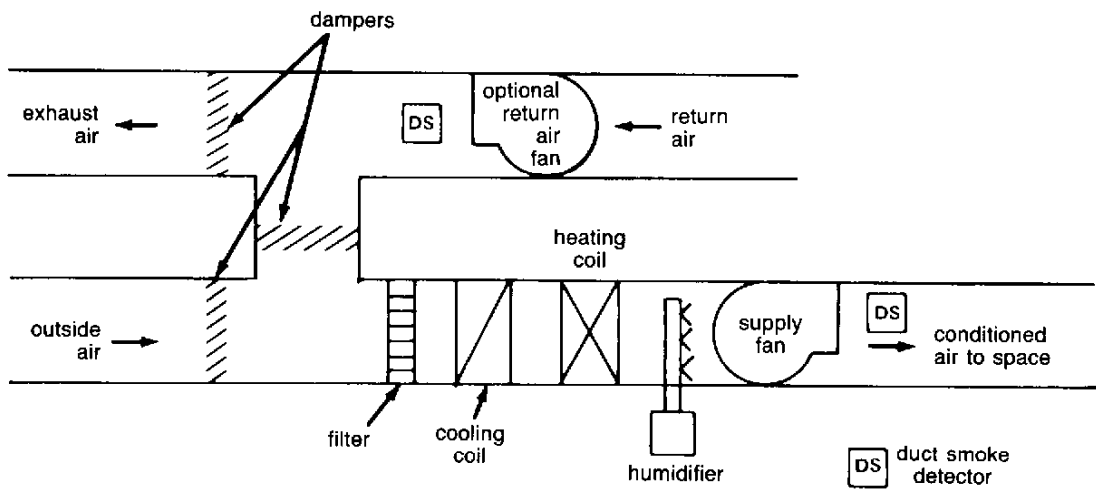

Figure C: Typical Single Zone System

6.1.2 Mounting the Air Duct Housing (see Figure D, page 9)

- a. Disassemble the housing by removing the detector cover, the integral wiring compartment cover, the manifold assembly, filter, and the sensing head.

The 600 Series sensing head is removed by turning it counterclockwise 15° and then pulling it out. Set these items aside while mounting the housing base.

- b. Position the detector to use the maximum length inlet sampling tube extension when required.
- c. Affix the adhesive-backed template to the side of the ductwork. DO NOT position the template with edges angled with respect to air flow direction.
- d. Punch or drill (No. 35 drill bit) four 0.110 inch diameter pilot holes for No. 10 sheet metal screws.
- e. Cut or punch-out two, 1¾ inch diameter holes as indicated on the template.
- f. Attach the housing to the air duct using the four No. 10, 1 inch screws.

6.2 Selection and Installation of Optional Inlet Sampling Tube Extension

6.2.1 Selection of the *Optional* Inlet Sampling Tube Extension

Optional inlet sampling tube extensions are available in three lengths for use when required by code or specification. This product is approved for use with no extension tubes.

To select the appropriate length extension tube, determine the outside width of the duct. If the width is less than 12 inches, no extension tube is needed. If the width is greater than 12 inches, but less than 48 inches, select an extension tube length that will traverse a minimum of ¾ of the distance across the duct. It is not necessary to extend the sampling tube through the other side of the duct if the duct is less than 48 inches wide. The housing will provide ample support for the extension tube.

If the duct width is greater than 48 inches, and extension of the inlet sampling tube is required, use sampling tube model 205C. Trim the inlet sampling tube at the job site as described in 6.2.2.

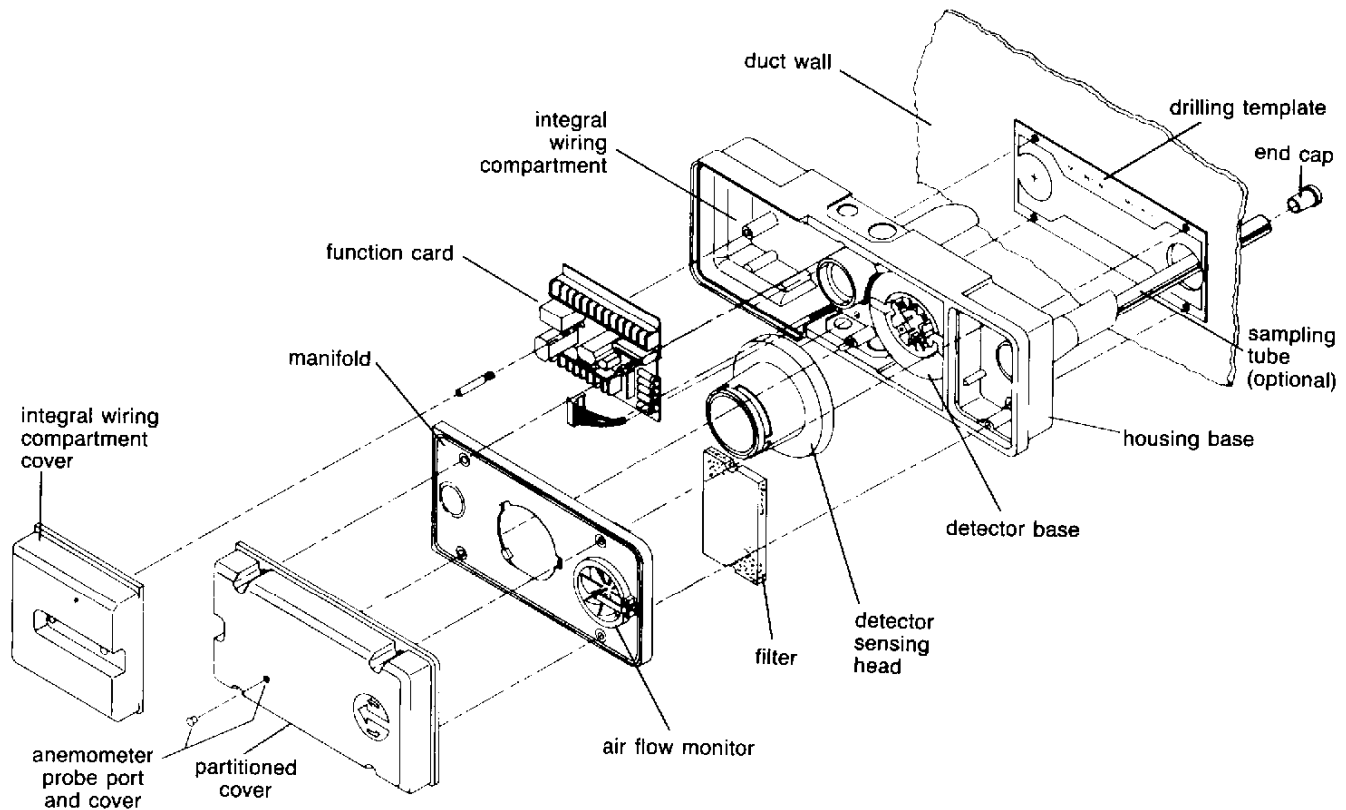

Figure D: Exploded View

Table 1. Selection of Optional Inlet Sampling Tube Extension

Outside Duct Width	Sampling Tube Model No.	Standard Tube Length
12 inches or less	None	—
12 inches to 24 inches	205A	24 inches
24 inches to 48 inches	205B	48 inches
48 inches to 93.75 inches	205C	96 inches
greater than 93.75 inches	Consult factory	—

6.2.2 Trimming the Inlet Sampling Tube Extension

- Measure the outside width of the duct.
- If the duct width is less than 48 inches, cut the selected tube to the same length as the duct width (minimum 3/4 of duct width). If the duct width is greater than 48 inches, add 2.25 inches to the duct width and cut Model 205C extension tube to this calculated length. This will allow the tube to extend 1 inch beyond the opposite duct wall for support.

Example: Outside width of duct 72.00 inches
 Add 2.25 inches + 2.25 inches
 Length of sampling tube 74.25 inches

- Remove all burrs. Leave the CAPLUG on the trimmed extension tube and discard the tube waste. the second CAPLUG on the piece of tube to be discarded is not needed and is only provided for protection of the tube end during shipping.

6.2.3 Installation of the Inlet Sampling Tube Extension

- Before installing the inlet sampling tube extension on ducts of widths greater than 48 inches, cut a 3/4 inch hole in the duct wall that is directly opposite the integral inlet sampling tube of the duct detector housing. This will allow the inlet tube to protrude through the opposite duct wall.
- Slide the retaining assembly 1/2 inch onto the end of the sampling tube without the CAPLUG and tighten the SEMS nut (see Figure E).
- To install the inlet tube, insert it through the air sampling chamber, rotate it and seat it (the retaining assembly is “keyed”). Secure it with the machine screw (#8-32 x 3/8”) and #8 flat washer provided (see Figure E).
- In installations where the extension tube protrudes through the opposite wall of the duct, make sure the CAPLUG is in place and completely seal the area where the tube meets the wall. Use a material such as DUXSEAL or an equivalent.

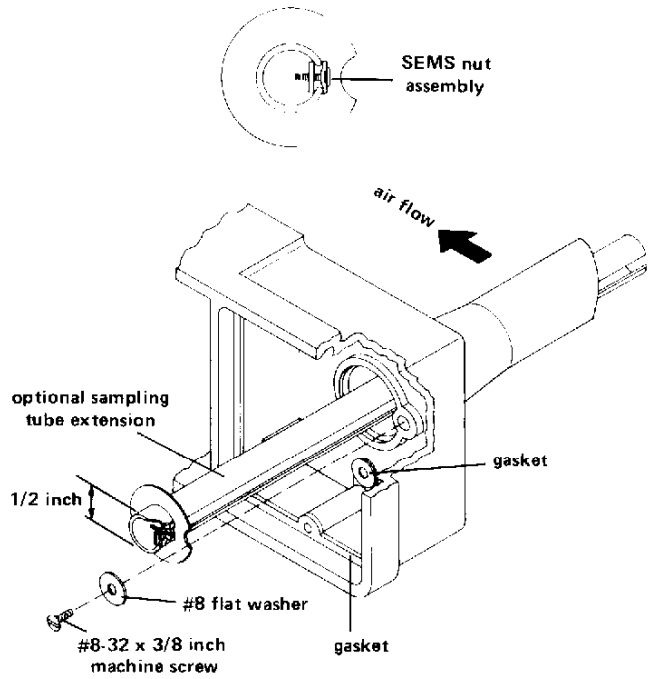

Figure E: Installation of Inlet Sampling Tube Extension

7.0 CONTINUATION OF EARTH GROUNDED CIRCUIT

WARNING: Failure to provide the proper earth grounding and continuation of conduit ground could result in fatal electrical shock.

Conduit Continuation

The 609U00 housing is provided with an internal metal plate in the base. Continuity of the input conduit and output conduit must be provided when a voltage in excess of 30 VAC or 42.4 VDC is carried through the conduit, to provide for earth ground continuation. This is accomplished by means of appropriate conduit fittings and locknuts which are screwed to the conduit and securely tightened to ensure the proper connection between conduit and internal plate.

This earth ground conduit continuation must be completed when one of the line voltage function cards is used, or when relay contacts are used with potentials of greater than 30 VAC or 42.4 VDC. A green stud and nut (marked “GND”) that can be used for direct ground termination, is provided on the metal plate.

9.2.1 Two-Wire Initiating Circuit Applications

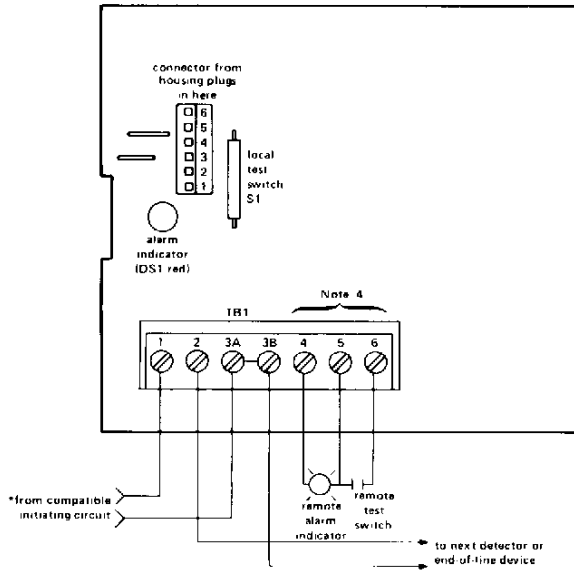

Figure WD1: Model 609U10
Compatibility identifier S00

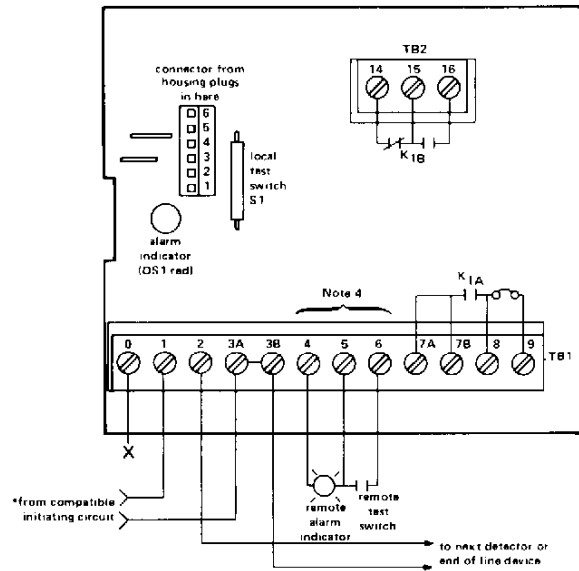

Figure WD2: Model 609U11
Compatibility identifier S02

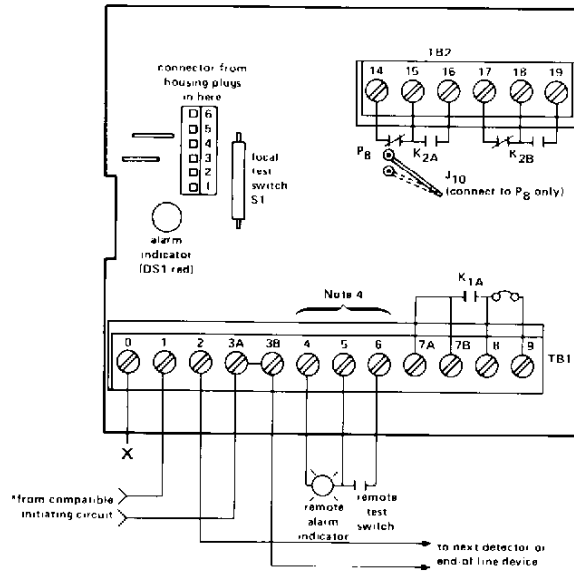

Figure WD3: Model 609U12
Compatibility identifier S36

Emergency Operation [Style D (Class A)]: Return initiating circuit wiring to appropriate control unit terminals and connect the end-of-line devices per the control unit instructions.

CAUTION: DO NOT use looped wire under screw terminals. These terminals are designed to prevent looping of an unbroken wire around or under a terminal screw in a manner that would permit the looped wire to remain unbroken during installation. This would preclude supervision if the wire were to dislodge from the terminal.

NOTES:

1. Relay contacts are shown with power applied and the system in the normal, supervisory (no alarm or trouble) condition. Refer to "Specifications" (Section 17.0, page 21) for contact rating of relay(s) and other electrical specifications.
4. For remote alarm indication, use ESL Model 606U1 and wire as shown in Figure RWD1.
For remote test and alarm indication, use ESL Model 606U2 and wire as shown in Figure RWD2.

9.2.2 Four-Wire Initiating Circuit Applications—Low Voltage Function Cards

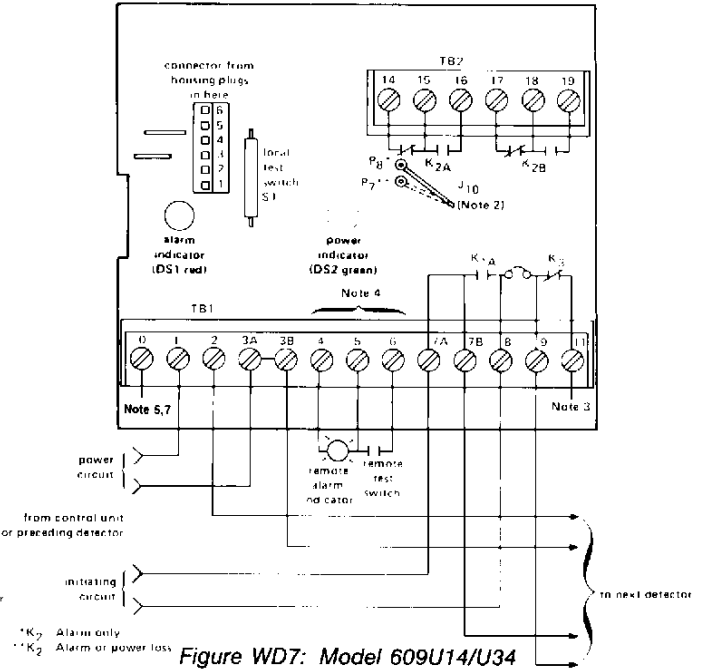
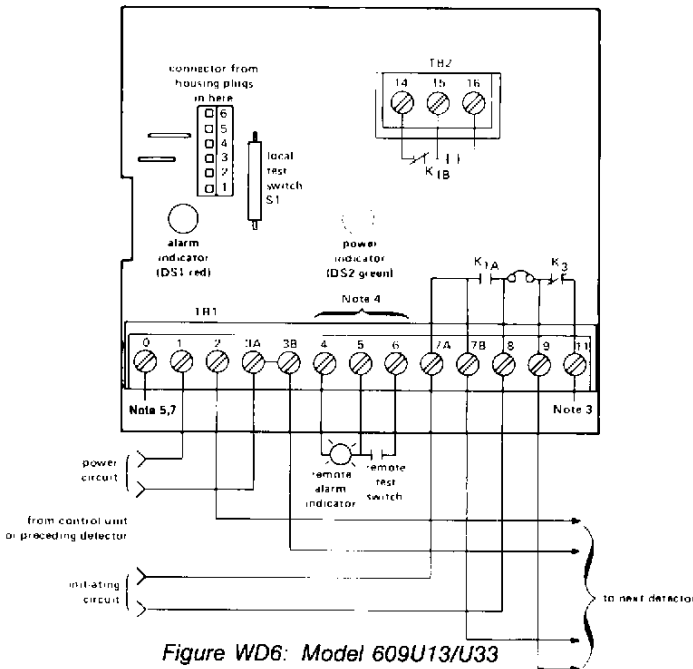
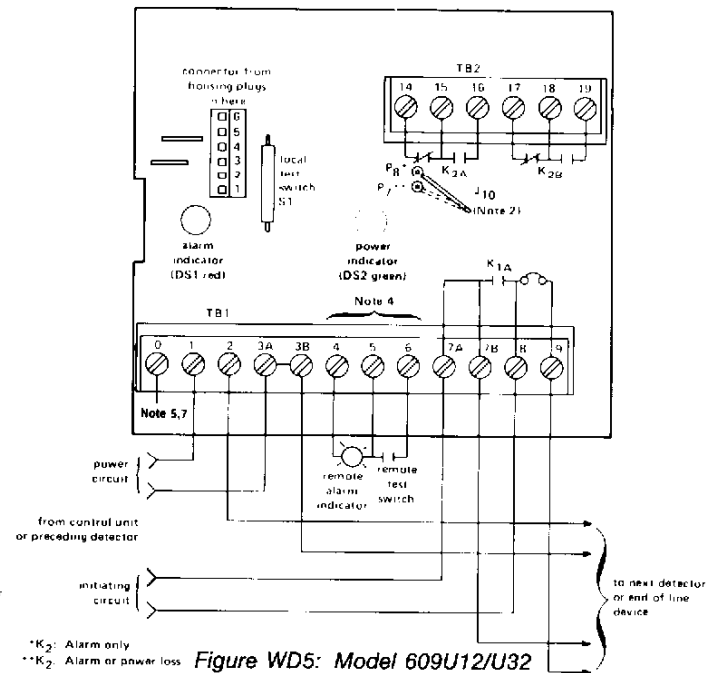
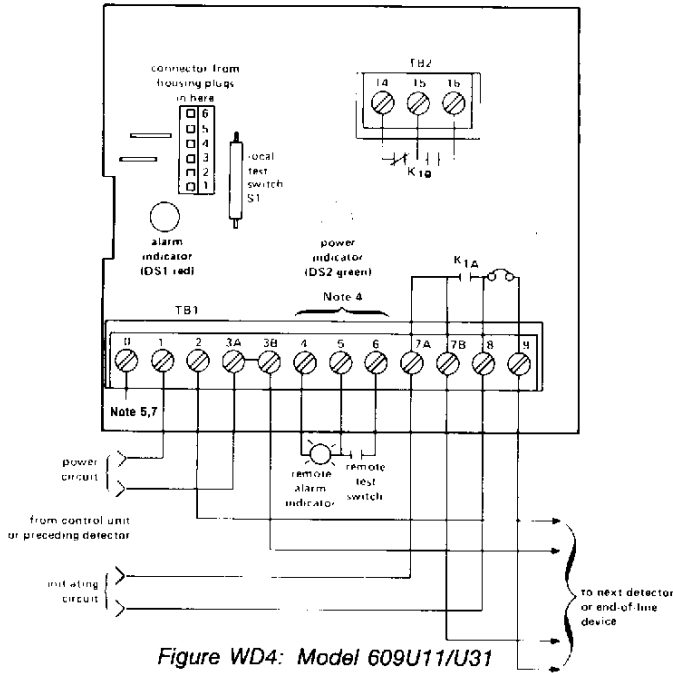

Emergency Operation [Style D (Class A)]: Return initiating circuit wiring to appropriate control unit terminals and connect the end-of-line devices per the control unit instructions.

CAUTION: DO NOT use looped wire under screw terminals. These terminals are designed to prevent looping of an unbroken wire around or under a terminal screw in a manner that would permit the looped wire to remain unbroken during installation. This would preclude supervision if the wire were to dislodge from the terminal.

NOTES:

- Relay contacts are shown with power applied and the system in the normal, supervisory (no alarm or trouble) condition. Refer to "Specifications" (Section 17.0, page 21) for contact rating of relay(s) and other electrical specifications.
- As supplied, K₂ contacts transfer on alarm only. To make K₂ normally operated providing transfer on alarm, power loss, or sensing head removal, remove J₁₀ from P₈ and reconnect to P₇ (see Section 17.2, Note 2, page 22).
- When the relay contacts of K_{1A} are connected to a supervised fire alarm system initiating circuit, the supervisory (trouble) contacts of K₃ must be wired electrically beyond the last initiating device, so as not to prevent an alarm being received at the control unit. When used in this manner, see Figures AWD1 and AWD2 for wiring connections.
- For remote alarm indication, use ESL Model 606U1 and wire as shown in Figure RWD1.
For remote test and alarm indication, use ESL Model 606U2 and wire as shown in Figure RWD2.
- For remote reset with remote test and remote alarm indication, use ESL Model 606U3.
With function cards 609U11, 609U12, 609U13, and 609U14; wire as shown in Figure RWD3.
- Green LED "Power-On" indicator on Models U31, U32, U33, and U34 only.
- For local reset use ESL Model 609URS, remove J₁₁ and wire across terminals 0 and 1.

9.2.3 Stand-Alone Releasing Service Applications—Low Voltage Function Cards

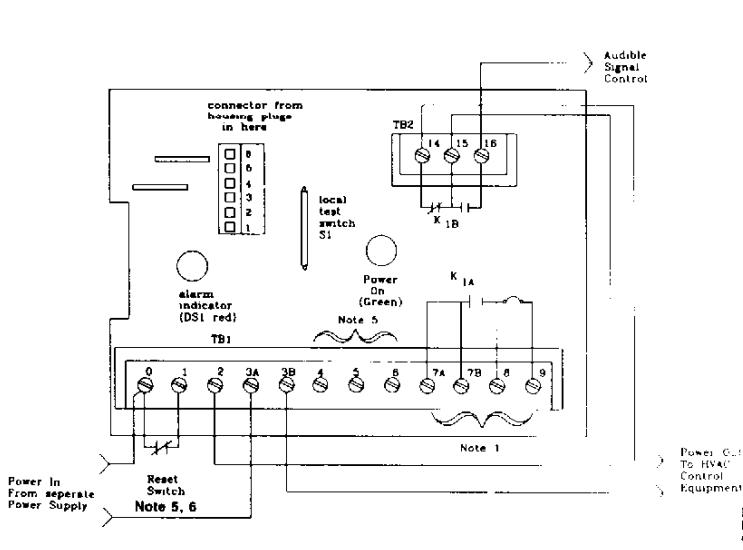

Figure WD8: Model 609U31

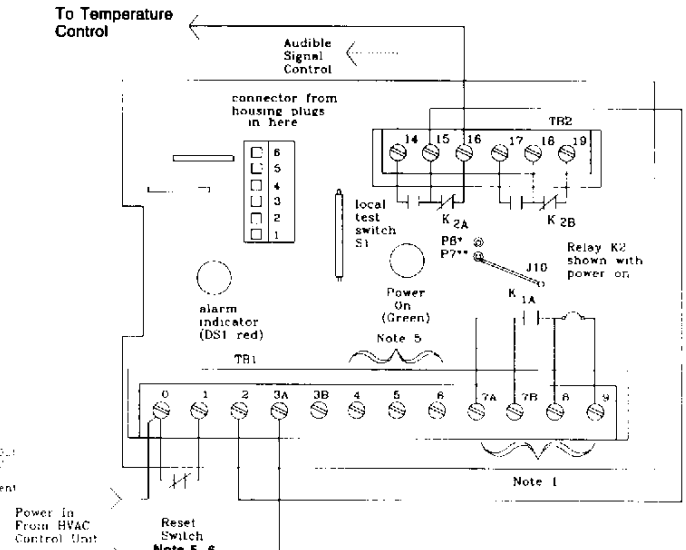

Figure WD9: Model 609U32

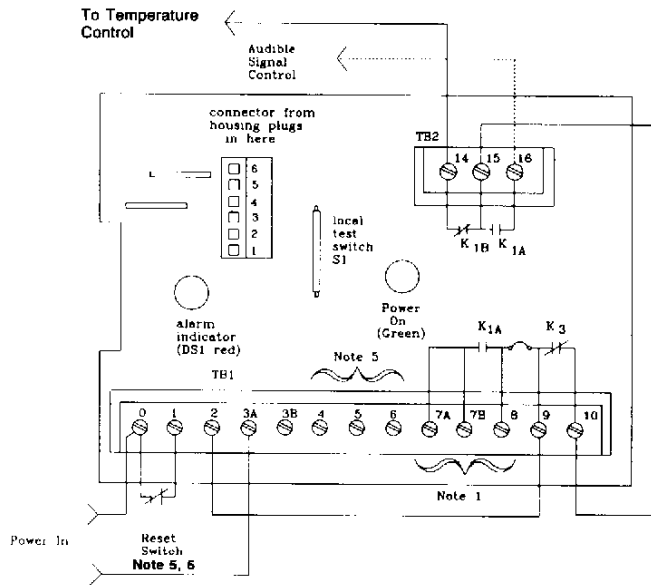

Figure WD10: Model 609U33

Emergency Operation [Style D (Class A)]: Return initiating circuit wiring to appropriate control unit terminals and connect the end-of-line devices per the control unit instructions.

CAUTION: DO NOT use looped wire under screw terminals. These terminals are designed to prevent looping of an unbroken wire around or under a terminal screw in a manner that would permit the looped wire to remain unbroken during installation. This would preclude supervision if the wire were to dislodge from the terminal.

NOTES:

1. Relay contacts are shown with power applied and the system in the normal, supervisory (no alarm or trouble) condition. Refer to "Specifications" (Section 17.0, page 21) for contact rating of relay(s) and other electrical specifications.
2. For remote audible signal use buzzer or horn with a voltage rating compatible with the power supplied to the duct detector.
3. For reset at the detector, use 609 URS and mount in conduit knockout.
4. For remote alarm indication, use ESL Model 606U1 and wire as shown in Figure RWD1.
For remote test and alarm indication, use ESL Model 606U2 and wire as shown in Figure RWD2.
5. For remote test and remote reset and remote alarm indication, use ESL Model 606U3.
With function cards 609U11, 609U12, 609U13, and 609U14; wire as shown in Figure RWD3.
6. For local reset use ESL Model 609URS, remove J₁₁ and wire across terminals 0 and 1.

9.2.4 Four-Wire Initiating Circuit or Stand-Alone Releasing Service Applications—Line/Low Voltage Function Cards

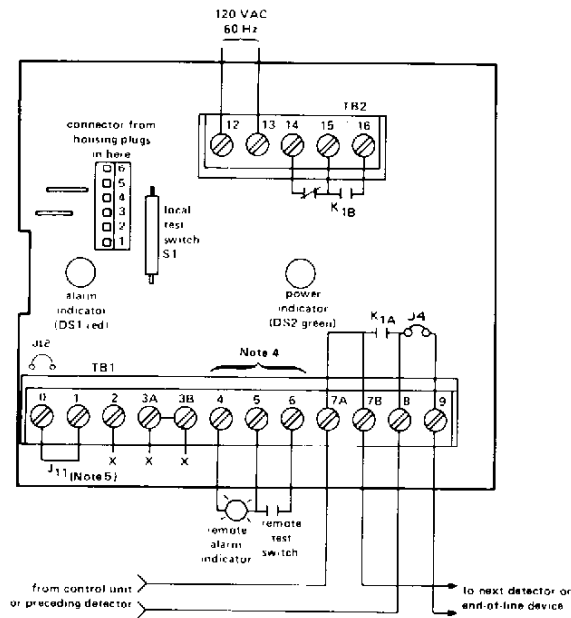

Figure WD11: Model 609U21

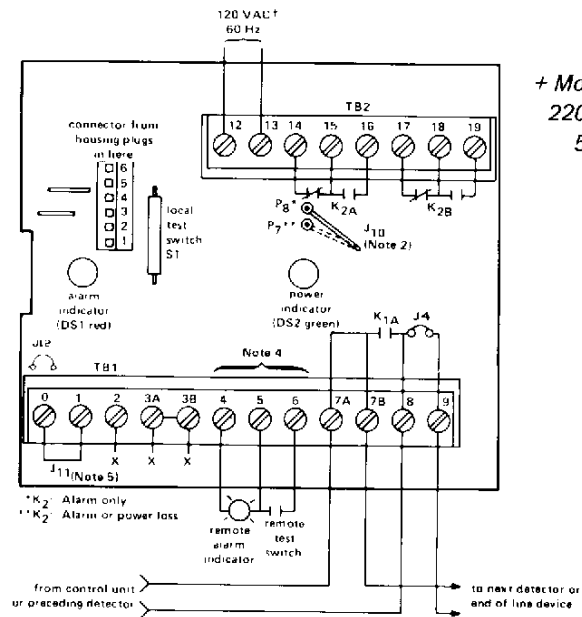

Figure WD12: Model 609U22/609U25

+ Model 609U25
220/240 VAC
50/60 Hz

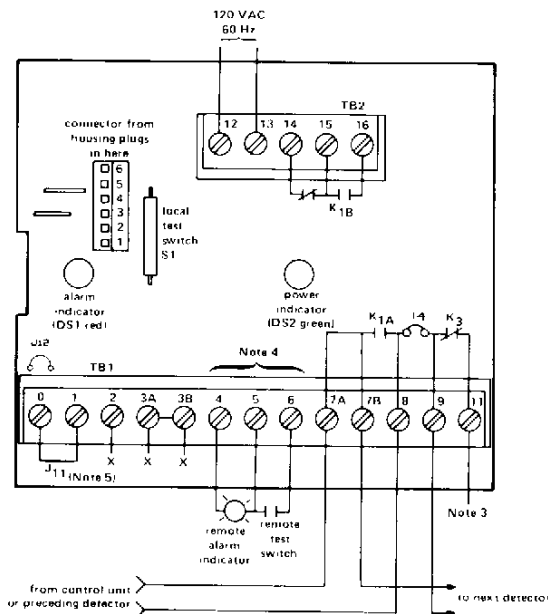

Figure WD13: Model 609U23

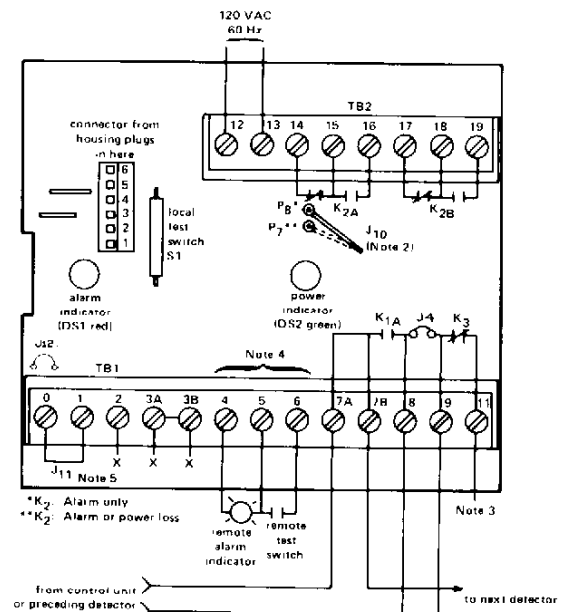

Figure WD14: Model 609U24

Emergency Operation [Style D (Class A)]: Return initiating circuit wiring to appropriate control unit terminals and connect the end-of-line devices per the control unit instructions.

CAUTION: DO NOT use looped wire under screw terminals. These terminals are designed to prevent looping of an unbroken wire around or under a terminal screw in a manner that would permit the looped wire to remain unbroken during installation. This would preclude supervision if the wire were to dislodge from the terminal.

NOTES:

- Relay contacts are shown with power applied and the system in the normal, supervisory (no alarm or trouble) condition. Refer to "Specifications" (Section 17.0, page 21) for contact rating of relay(s) and other electrical specifications.
- As supplied, K₂ contacts transfer on alarm only. To make K₂ normally operated providing transfer on alarm, power loss, or sensing head removal, remove J₁₀ from P₈ and reconnect to P₇ (see Section 17.2, Note 2, page 22).
- When the relay contacts of K_{1A} are connected to a supervised fire alarm system initiating circuit, the supervisory (trouble) contacts of K₃ must be wired electrically beyond the last initiating device, so as not to prevent an alarm being received at the control unit. When used in this manner, see Figures AWD1 and AWD2 for wiring connections.
- For remote alarm indication, use ESL Model 606U1 and wire as shown in Figure RWD1.
For remote test and alarm indication, use ESL Model 606U2 and wire as shown in Figure RWD2.
- For remote reset with remote test and remote alarm indication, use ESL Model 606U3.
With function cards 609U21, 609U22, 609U23, 609U24, and 609U25, remove J₁₁ and wire as shown in Figure RWD4.
- For local reset use ESL Model 609URS, remove J₁₁ and wire across terminals 0 and 1.

Figure AWD2

Alternate wiring for function cards 609U13, 609U14, 609U23, and 609U24. The supervisory relay (K₃) contact of each card is required.

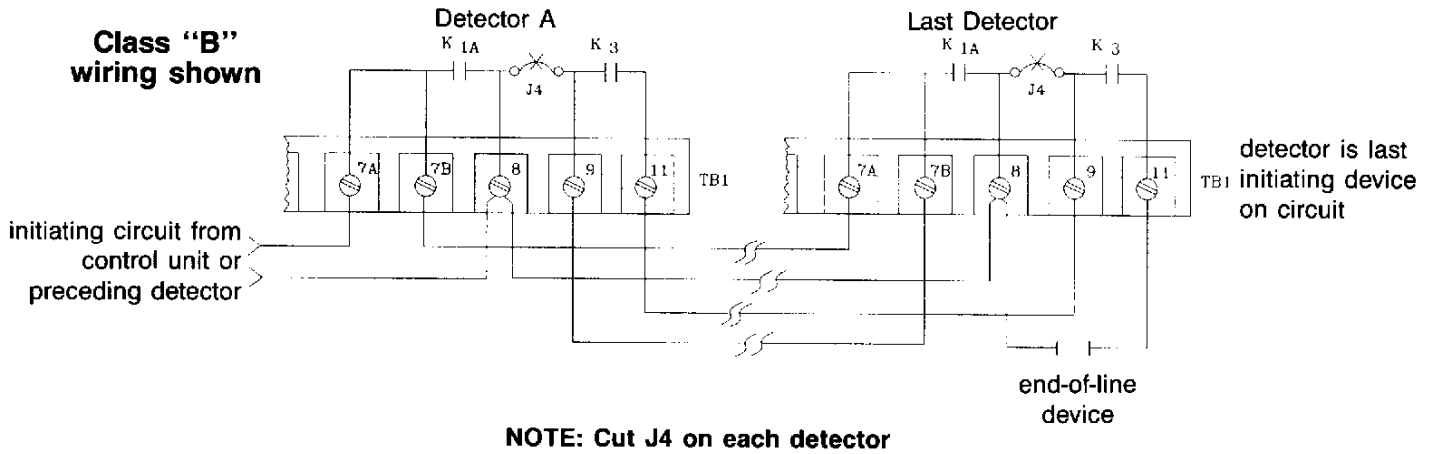
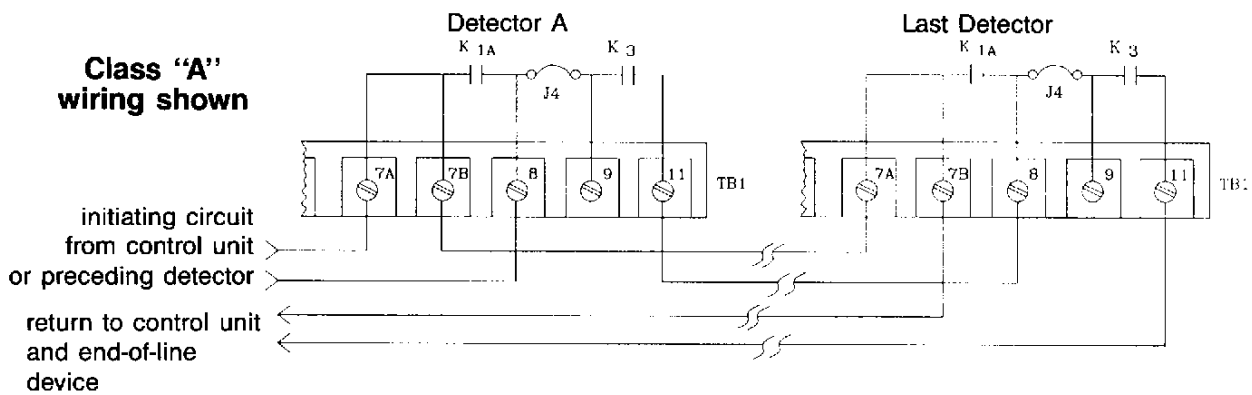

Figure AWD2A

Alternate wiring for function cards 609U13, 609U14, 609U23, and 609U24. The supervisory relay (K₃) contact of each card is required.



9.2.5 Alternate Wiring Diagrams

Figure AWD1

Alternate wiring for function cards 609U13, 609U14, 609U23, and 609U24 as an end-of-line detector with supervisory signaling on power loss.

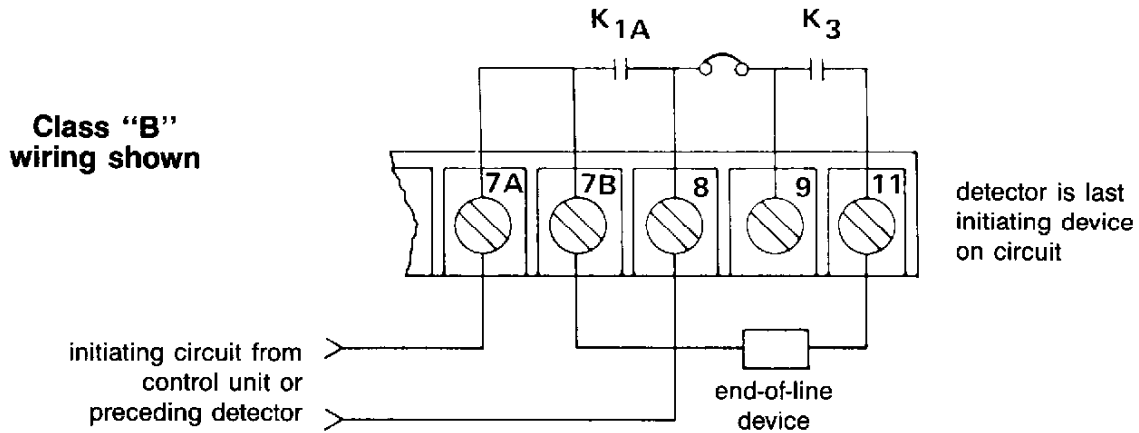
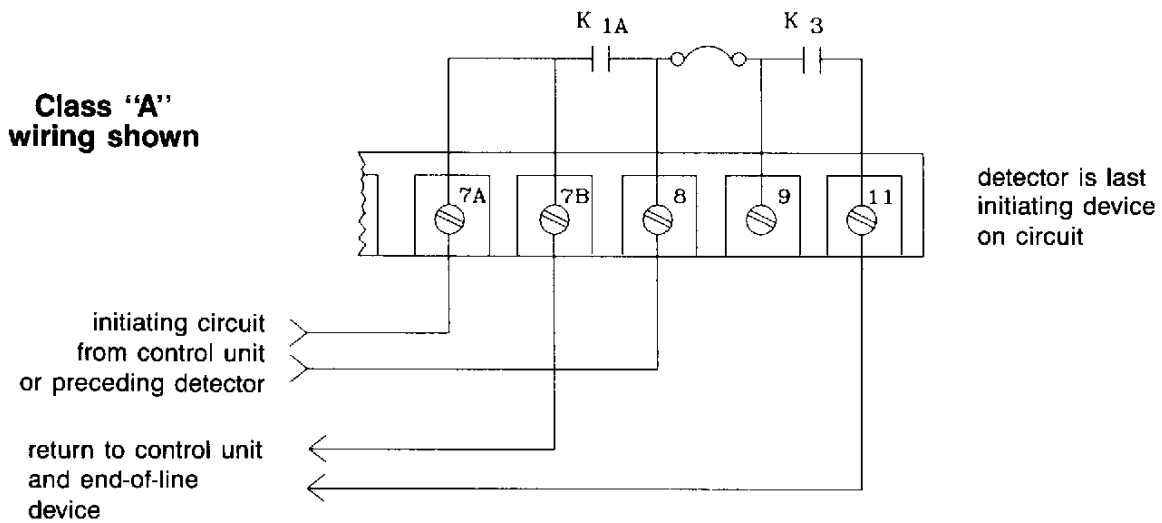

Figure AWD1A

Alternate wiring for function cards 609U13, 609U14, 609U23, and 609U24 as an end-of-line detector with supervisory signaling on power loss.



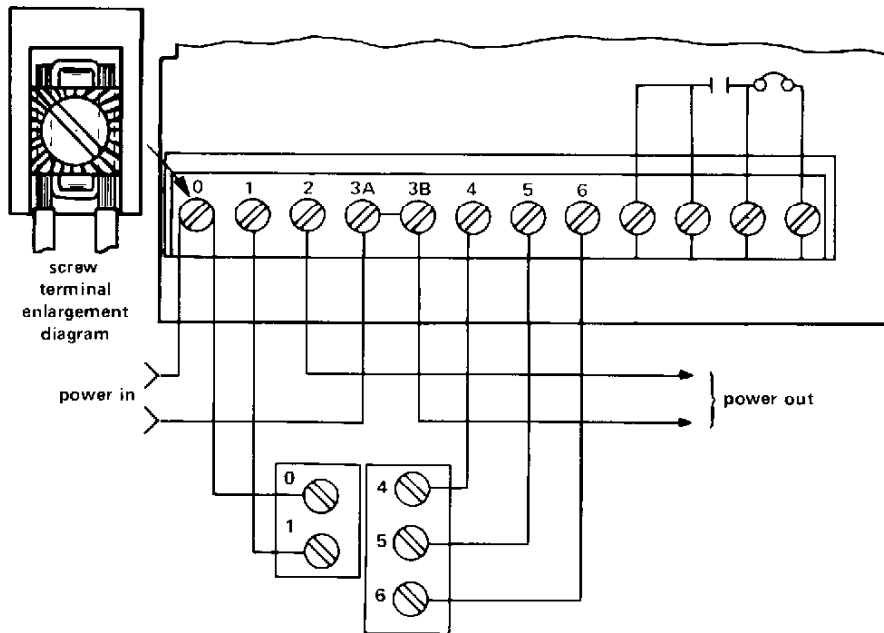

Figure RWD3: Wiring Connections for Model 606U3 with 609U11, 609U12, 609U13, 609U14, 609U31, 609U32, 609U33, and 609U34 Function Cards. (Only accessory wiring shown for clarity.)

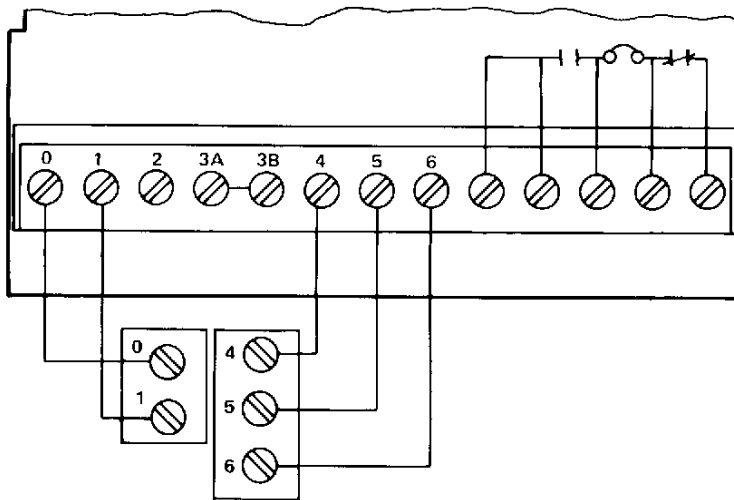

Figure RWD4: Wiring Connections for Model 606U3 with 609U21, 609U22, 609U23, 609U24, and 609U25 Function Cards. Remove Jumper (J₁₁) from Terminal 0 and 1. (Only accessory wiring shown for clarity.)

12.0 INSTALLATION OF THE SENSING HEAD

After completing the installation of the duct housing, the function card, and its wiring, check the system wiring for continuity.

NOTE: Before installing the sensing head into the housing, be certain to purge the air handling system of construction debris and other foreign materials by activating the system, if possible. Otherwise the sensing head may become contaminated and require immediate servicing.

A unique, manually operated switch located in the sensing head mounting base establishes continuity across Terminals 1 and 2 at initial installation of the low voltage function cards. The switch is in the closed position on new housings, and is automatically opened when the sensing head is plugged in. If a sensing head is removed from service, the switch may be reset using a small screwdriver, to re-establish circuit continuity.

To install a sensing head:

1. Insert the head and rotate it until it is properly aligned and sets into the base.
2. Rotate the head an additional 15° so that it will automatically lock into place.

CAUTION: The ESL air duct detector assemblies have been designed for use with ESL Models 611UD and 612UD sensing heads. **DO NOT USE ANY OTHER SENSING HEAD.** These are the only sensing heads authorized for use.

To remove a sensing head:

1. Rotate the head counterclockwise 15° until a stop is felt.
2. Pull the head straight out.

10.0 CONTROL OF NORMALLY ENERGIZED AND DE-ENERGIZED DEVICES

The auxiliary relay contacts available at terminals 14 through 19 on models so equipped, may be used to control normally energized and de-energized devices that do not exceed the contact ratings of the particular function card.

- Wire normally energized devices (fans, blowers, etc.) to the normally closed contacts between terminals 14 and 15, or 17 and 18, to shut down these devices on alarm.
- Wire normally de-energized devices (extinguishers, smoke removal fans, etc.) to the normally open contacts between terminals 15 and 16, or 18 and 19, to activate these devices on alarm.

- If you want devices to energize or de-energize upon power loss or alarm of the air duct smoke detector (as is possible with those function cards equipped with the 10 Ampere relay), program the relay as described in Note 2 of the function card wiring diagrams. Wire normally energized devices between terminals 15 and 16, or 18 and 19, to shut down on power loss or alarm. Wire normally de-energized devices between terminals 14 and 15, or 17 and 18, to activate on power loss or alarm (see Section 9.2).

11.0 ACCESSORY INSTALLATION

ESL 600 Series accessories—model 606U1 remote alarm indicator, model 606U2 remote test and alarm indicator and model 606U3 remote alarm indicator with remote test and reset may be used to enable several of the detector functions from a remote location.

These accessories mount to a standard single-gang electrical box with a minimum depth of 1-3/8 inches. Wiring connections should be made prior to attaching these remote stations to the box, in accordance with the appropriate wiring diagrams.

11.1 Wiring Diagrams

- a. Model 606U1 Wiring Diagram—Figure RWD1
- b. Model 606U2 Wiring Diagram—Figure RWD2
- c. Model 606U3 Wiring Diagram with function card models 609U11, 609U12, 609U13, 609U14, 609U31, 609U32, 609U33, and 609U34—Figure RWD3
- d. Model 606U3 Wiring Diagram with function card models 609U21, 609U22, 609U23, 609U24, and 609U25—Figure RWD4

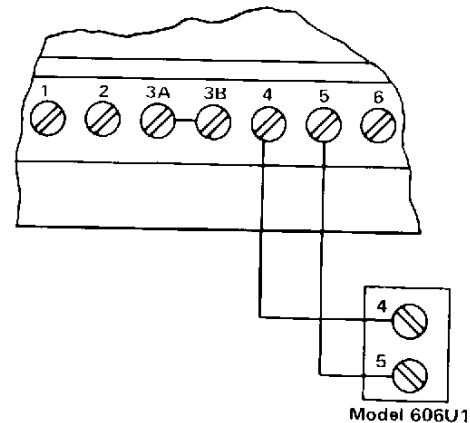

Figure RWD1: Wiring Connections for Model 606U1 with any 609 Series Function Card. (Only accessory wiring shown for clarity.)

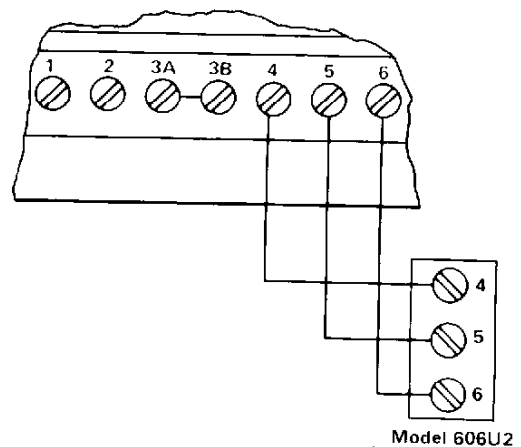

Figure RWD2: Wiring Connections for Model 606U2 with any 609 Series Function Card. (Only accessory wiring shown for clarity.)

8.0 FUNCTION CARD INSTALLATION

1. If the function card compartment cover is installed, remove it.
2. Install the selected function card into the compartment as shown in Figure A (page 3). The notched edge of the function card installs toward the inside of the housing by placing it under the two retaining tabs molded in the base.
3. Secure the function card with the threaded standoff included in the hardware package.
4. Plug the wiring connector from the sensing head into its mating connector on the function card.

8.1 Installation of Local Reset Switch 609URS

1. To install the local reset switch, ESL Model 609URS, locate and remove the 7/8 inch knockout closest to terminals 0 and 1 on function card.
2. Dress the switch wires through the knockout hole and into the function card compartment.
3. Snap the reset switch into the conduit opening securely.
4. Loosen screw terminals 0 and 1, then remove the metal shorting strap between the terminals and discard.
5. Strip 3/8 inches of insulation from each conductor and insert one wire under each terminal 0 and 1 then tighten screws.
6. To complete the wiring use appropriate information in Section 9.2.

9.0 ELECTRICAL WIRING

All wiring must be installed in compliance with the National Electrical Code (NFPA 70) and/or the local code(s) having jurisdiction. All field wiring connections are made to the terminal block(s) on the function card.

The electrical wiring of the selected function card should be wired in accordance with the wiring diagrams that immediately follow the wiring procedure instructions (Section 9.2).

9.1 Wiring Procedure

1. Strip 3/8 inches of insulation from each conductor and insert each one under the appropriate screw terminal.

NOTE: The barrier type terminal block will accommodate one wire of 12 AWG to 18 AWG under each side of each screw/clamping plate. This design prevents "looping" of wires and provides for supervision of the installation wiring connections. Duplicate terminal positions are provided for all connections necessary for alarm initiation.

2. Tighten the screws.
3. Check all wiring connections.
4. Replace compartment cover and tighten retaining screw.

9.2 Wiring Diagrams

Two-Wire Initiating Circuit Applications

- a. 609U10 Wiring Diagram—Figure WD1
- b. 609U11 Wiring Diagram—Figure WD2
- c. 609U12 Wiring Diagram—Figure WD3

Four-Wire Initiating Circuit Applications—Low Voltage Function Cards

- d. 609U11/U31 Wiring Diagram—Figure WD4
- e. 609U12/U32 Wiring Diagram—Figure WD5
- f. 609U13/U33 Wiring Diagram—Figure WD6
- g. 609U14/U34 Wiring Diagram—Figure WD7

Stand-Alone Releasing Service Applications—Low Voltage Function Cards

- h. 609U31 Wiring Diagram—Figure WD8
- i. 609U32 Wiring Diagram—Figure WD9
- j. 609U33 Wiring Diagram—Figure WD10

Line Voltage Function Cards

- k. 609U21 Wiring Diagram—Figure WD11
- l. 609U22, 609U25 Wiring Diagrams—Figure WD12 (+ 220/240 VAC, 50/60 Hz on model 609U25)
- m. 609U23 Wiring Diagram—Figure WD13
- n. 609U24 Wiring Diagram—Figure WD14
- o. Alternate wiring diagram for function cards 609U13, 609U14, 609U23, and 609U24 when used as an end-of-line detector with power supervision—Figure AWD1.
- p. Alternate wiring diagram for function cards 609U13, 609U14, 609U23, and 609U24 when NOT the last detector on the circuit and, power supervision of each card is required. (*Jumper J4 must be cut on each function card wired in this manner*)—Figure AWD2.
- q. Wiring diagram for connection of a fire alarm initiating circuit to a four-wire function card.
- r. Alternate wiring diagram for connection of a fire alarm initiating circuit when Jumper J4 has been cut or terminal #9 is not connected to the normally open alarm contacts.

NOTE: All notes for each wiring diagram must be read carefully *PRIOR* to making connections.

17.3 Function Card Schematic Diagrams

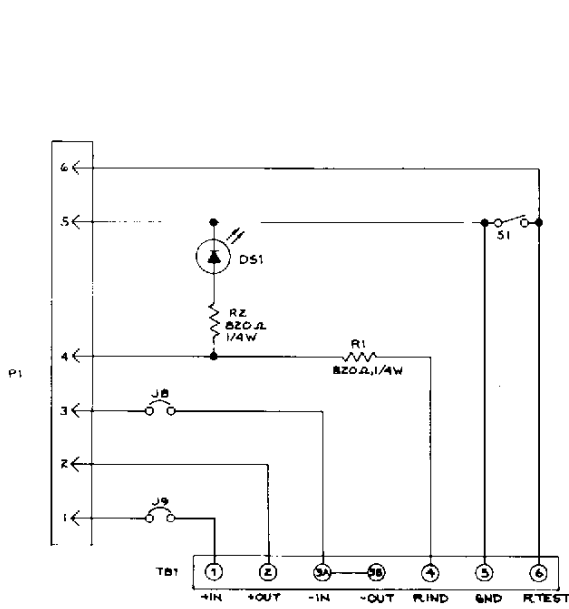

609U10

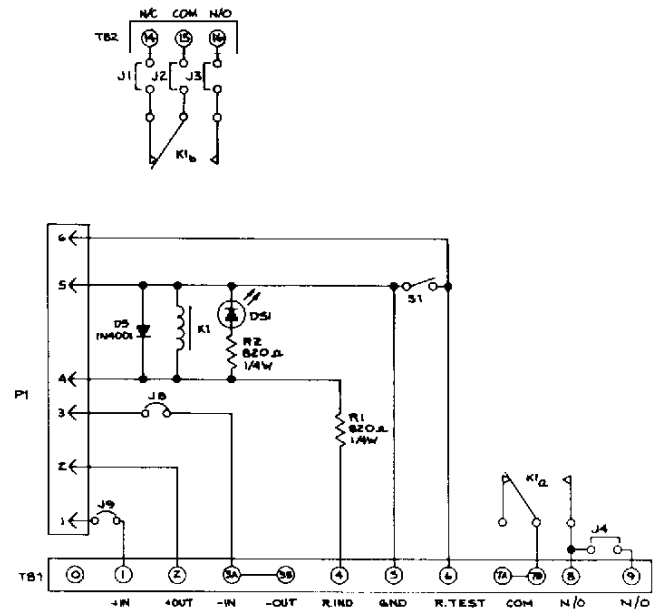

609U11/U31

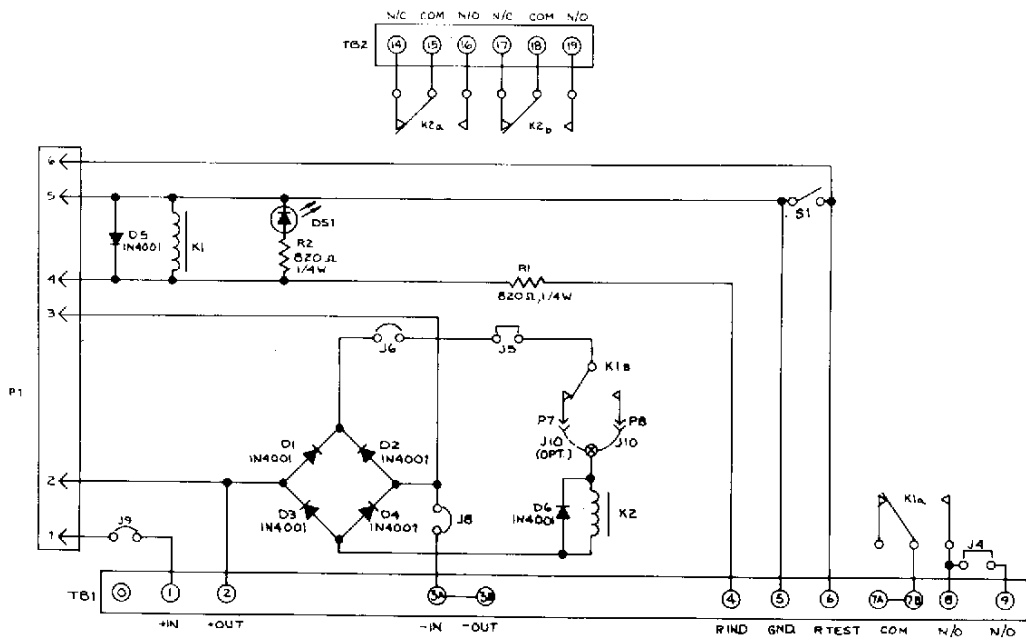

609U12/U32

13.0 AIR DUCT SAMPLING TUBE PRESSURE MEASUREMENT

The ESL 609 Series air duct type detectors are Listed by Underwriters Laboratories in an air duct velocity range of 300 to 4000 feet per minute with 611UD and 2000 feet per minute with 612UD. If desired, a pressure reading instrument such as an inclined or vertical manometer may be used to determine the air velocity within the duct.

Also, a pressure differential measurement between the inlet and exhaust sampling tubes of the air duct detector housing may be used to assure the user of the probability of air flow through the housing. NOTE: This measurement must be made prior to completion of the detector installation.

14.0 COMPLETING THE INSTALLATION

1. Ensure that the sampling tube extension (if used) is secured.
2. Install the manifold assembly. Be certain that the inlet air filter on the underside of the manifold and the air flow monitor are in place as shown in Figure D, page 9. The manifold will push on over the sensing head and seat on the base of the duct housing. If the manifold does not install easily, it may be necessary to lubricate the round gasket that surrounds the sensing head.
3. Install the partitioned cover and secure it with the four #8-32 machine screws (1-3/8 inch long) with shoulder washers.
4. Position the function card compartment cover and secure it with the remaining 1 inch long #8-32 machine screw.

15.0 AIR VELOCITY MEASUREMENT

15.1 Air Flow Monitor

The ESL Series 609 air duct type detector includes a unique air flow monitor (see Figure D, page 9) which is visible through the clear cover. By observing that the monitor is rotating, the viewer is assured of the presence and direction of air movement through the sensing area of the enclosure.

If the air flow monitor fails to rotate, then the velocity of air through the detector is low. This does **NOT** mean that the detector will not function—only that the air velocity in the air duct is low (typically, less than 350 FPM), or that the filter is in need of cleaning.

Actual air velocity through the detector sensing area may be measured using the method described in the following section (Section 15.2).

15.2 Sensing Chamber Air Velocity Measurement Using a Thermo Anemometer

A front cover probe port (see Figure D, page 9) is provided for in-place measurement of the actual air velocity through the detector using a Thermo-Anemometer, such as the Alnor Type 8500.

To obtain this measurement, do the following:

1. Remove the probe port cover and retain.
2. Insert the probe through the opening and rotate it to "peak" the reading on the Thermo-Anemometer. When the seal between the anemometer probe and the port is inadequate, a rubber grommet slid over the shaft of the probe will provide an improved seal.
3. Record the air velocity measurement for future reference.
4. Remove the probe and *be sure to replace the probe port cover.*

NOTE: Air velocity measurements through the probe port that are less than 30 FPM, but greater than 10 FPM, are sometimes encountered when the air velocity within the duct is low. The detector will respond to a smoke condition exceeding the alarm threshold, but response may be delayed by the slow smoke travel. Consider installing an area type smoke detector listed for the purpose, or a listed optical beam smoke detector.

16.0 MAINTENANCE AND TESTING

Under normal conditions, detectors should be given routine maintenance at least twice a year—more frequently in dirtier environments. All detectors should be tested at least twice a year. Notify the proper authorities that the smoke detector system is undergoing maintenance and/or being tested, and will temporarily be out of service.

CAUTION: *Disable the zone or system being serviced. All persons who would automatically receive a real fire alarm signal should be notified to prevent an unnecessary response.*

When testing and maintenance are completed, restore the zone or system to normal standby operation. Notify all appropriate people that testing has been completed, and that the system is again operational.

16.1 Testing

With the air handling system shut down and power applied to the detector, perform one of the following tests:

Local testing may be accomplished using the ESL Model 605A3 magnet test tool as follows:

1. Insert the magnet through the opening provided in the function card cover, and seat it against the printed circuit card.

- Maintain the magnet in this position for 20 seconds. If the test of the smoke sensing head is successful, the local alarm LED and remote alarm LED of a model 606 remote station will light, and the alarm relay contacts (if so equipped) will transfer.

Remote testing using the remote station key switch is accomplished as follows:

- Operate the key switch of the ESL Model 606U2 or the Model 606U3 remote station for 20 seconds. As with the local method, if the test of the smoke sensing head is successful, the local alarm LED and remote alarm LED of the remote station will light, and the alarm relay contacts (if so equipped) will transfer.

Receipt of an alarm signal (if any) at the fire alarm control unit should be verified after testing each detector. Reset the fire alarm system and the air duct type detector by operating the system reset switch for 2 seconds, removing power from the detector. Reset of the detector alone may be accomplished using the Model 606U3 remote station. This is especially desirable in stand-alone releasing service applications.

If the detector test was done by means of a remote test station with no response, a local test as described in No. 1 above should be tried to isolate a fault in the remote station or its wiring. When a detector fails to respond to a test, a check of that location should be made to verify that operating power is being applied and that wiring terminal screws are tight. The green LED on line voltage function cards and low voltage function cards, so equipped, will be lit if power is present and the sensing head is installed.

A voltmeter should be used to measure for the proper operating voltage at terminals #2 and #3 on the low voltage function cards. Insure that the wiring connector from the sensing head is properly installed. If these conditions are met, then remove the sensing head from the housing, replace it with an *identical* ESL model, and repeat the test. Continued failure of the air duct detector assembly may indicate a faulty function card. Obtain a Return Authorization Number by calling 1-800-648-7422 or 503-620-8540, then carefully pack it and return it prepaid to Sentrol, Inc. Include an explanation of the suspected failure mode.

16.2 Maintenance

Maintenance of the air duct type detector may be done with a vacuum and/or oil-free air line to loosen dirt from the screen surrounding the sensing area.

The air inlet chamber filter should be cleaned semi-annually and replaced annually. More frequent cleaning may be required for installations with a high quantity of airborne contaminants (dust, etc.).

16.3 Detector Test and Maintenance Log

It is recommended that a permanent Detector Test Log be set up and maintained with a record for each individual smoke detector in each building. Each detector should be clearly described, with information on the type of detector, the model number, the serial number (if any), the location, the date installed, and the type of environment. Data entries should include test dates, type of test mode, test results, maintenance, and comments.

17.0 SPECIFICATIONS

The air duct smoke detector shall be either an ESL Model 611UD photoelectronic detector with a 609U00 enclosure or an ESL Model 612UD ionization detector with a 609U00 enclosure.

The base of the enclosure and the manifold shall be constructed of rigid structural foam, and shall incorporate an air-tight smoke chamber in compliance with UL268A Standard for smoke detectors for duct applications. The detector enclosure shall be equipped with an integral mounting base capable of accommodating photoelectronic detector heads, and shall be capable of local testing via a magnetic switch. The clear covers for the enclosure shall be constructed of Lexan®.

The detector shall operate at air velocities of 300 feet per minute to 2000 feet per minute. Either two-wire or four-wire Class A or Class B supervisory configurations shall be available. The duct detector shall be capable of interfacing directly with ESL 606 Series Remote Stations which shall provide local alarm indicator and test functions. The Model 606U3 Remote Station also provides a remote reset function.

An integral filter system shall be included to reduce dust and residue accumulation which could cause adverse effects on the detector and housing. An air flow monitor shall be included to indicate the presence and direction of air flow through the detector. Sampling tubes shall be easily installed after the housing is mounted to the duct, by passing them through the duct detector enclosure.

17.1 Product Data

Dimensions:

Length: 16.5 in. (42 cm)

Width: 5.5 in. (14 cm)

Depth: 4.0 in. (10 cm)

Integral sampling tubes extend the width by 5.5 inches and require two holes of 1¼ inches diameter for clearance.

Weight:

Maximum weight is 78.75 oz. (2.23 kg). This duct detector assembly would include the 609U00 enclosure, 611UD detector, and 609U24 electrical function card assembly.

Operating Temperature Range:

0–50°C, 32–120°F

Operating Humidity Range:

5–95% RH

Operating Duct Air Velocity Range:

300–2000 feet per minute

17.2 Function Cards

Table 1: Electrical Specifications—2-Wire Function Card Application

Model Number	Compatibility Indicator	Voltage Range Standby	Voltage Range Alarm	Standby Current	Alarm Current	Contacts
609U10	S00	8.5–44 VDC	33 VDC max.	50 μ A max.	60 mA max.	None
609U11	S02	8.5–44 VDC	33 VDC max.	50 μ A max.	60 mA max.	1A, 1C (2 Amp.) Alarm
609U12	S36	8.5–44 VDC	33 VDC max.	50 μ A max.	70 mA max.	1A (2 Amp.), 2C (10 Amp.) Alarm

Two-wire detectors must be connected only to listed compatible initiating circuits.

Table 2: Electrical Specifications—4-Wire Function Card Application, Line Voltage AC

Model Number	Voltage Range	Standby Current	Alarm Current	2 Amp. Alarm Contacts	10 Amp. Alarm Contacts	** 1 Amp. Supervisory Contacts
609U21	102–132 VAC	15 mA	20 mA	1 Form A 1 Form C	—	—
609U22	102–132 VAC	15 mA	20 mA	1 Form A	2 Form C	—
609U23	102–132 VAC	15 mA	20 mA	1 Form A 1 Form C	—	1 Form A
609U24	102–132 VAC	15 mA	20 mA	1 Form A	2 Form C	1 Form A
609U25	187–242 VAC	5 mA	10 mA	1 Form A	2 Form C	—

** Form A supervisory contacts are closed with power applied.

Table 3: Electrical Specifications—4-Wire Function Card Application, Low Voltage AC or DC

Model Number	Voltage Range	Standby Current	Alarm Current	2 Amp. Alarm Contacts	10 Amp. Alarm Contacts	** 1 Amp. Supervisory Contacts
609U11	8.5–33 VDC 24 VAC	50 μ A	48 mA	1 Form A 1 Form C	—	—
609U31	8.5–33 VDC 24 VAC	9 mA	57 mA	1 Form A 1 Form C	—	—
609U12	17–33 VDC 24 VAC	50 μ A *11 mA	59 mA 48 mA	1 Form A	2 Form C	—
609U32	17–33 VDC 24 VAC	9 mA *20 mA	68 mA 57 mA	1 Form A	2 Form C	—
609U13	17–33 VDC 24 VAC	8 mA	56 mA	1 Form A 1 Form C	—	1 Form A
609U33	17–33 VDC 24 VAC	17 mA	65 mA	1 Form A 1 Form C	—	1 Form A
609U14	17–33 VDC 24 VAC	8 mA *19 mA	67 mA 56 mA	1 Form A	2 Form C	1 Form A
609U34	17–33 VDC 24VAC	17 mA *28 mA	76 mA 65 mA	1 Form A	2 Form C	1 Form A

* Jumper J₁₀ on P₇ — 10 Amp. contact alarm relay normally operated.

** Form A supervisory contacts are closed with power applied.

NOTES:

1. When the 609U12 function card is used in a two-wire initiating circuit application, the 10 ampere relay must NOT be programmed for normally operated releasing service. If the relay were programmed, in this way, the normal operating current would be increased from 50 microamperes to 10 milliamperes.
2. The 10 Ampere contact relay of the 609U12 and the 609U14 function cards is field programmable to be normally operated, and to release on a) alarm, b) sensing head removal, or c) power loss. When so programmed, the standby current @ 24 VDC/VAC is increased to 10 milliamperes, and the alarm current is reduced by 10 milliamperes.
3. The contact ratings in the table above are for a resistive load at 30 VDC or 120 VAC maximum.

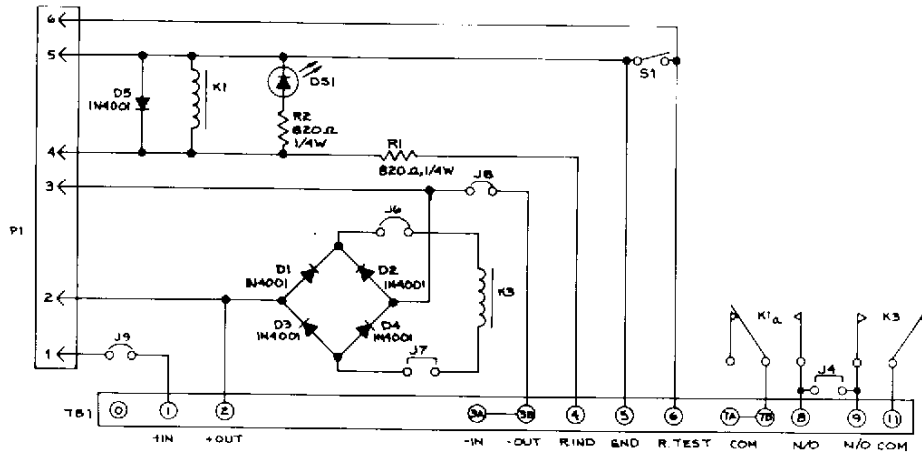
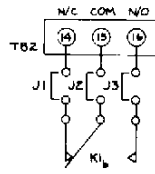

609U13/U33

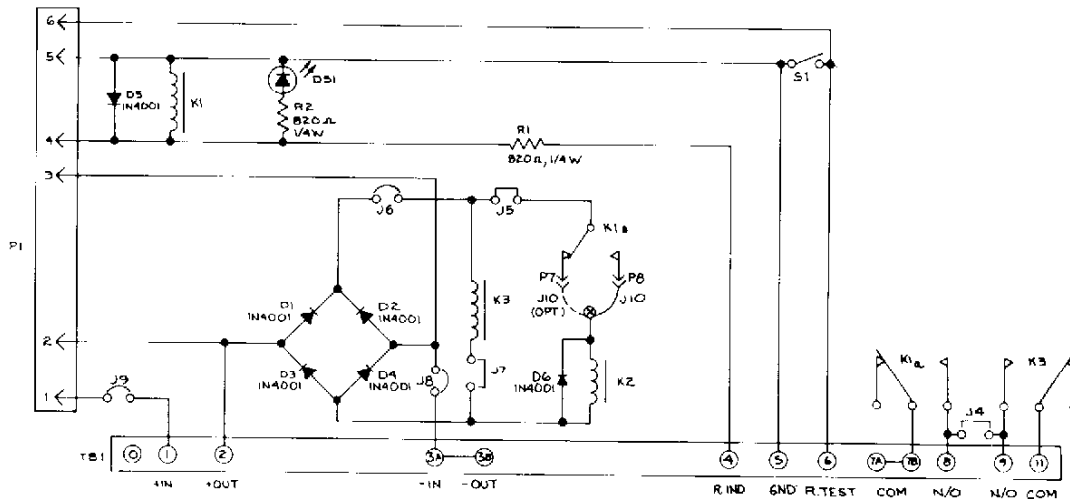
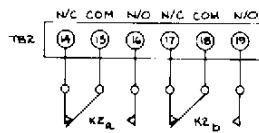

609U14/U34

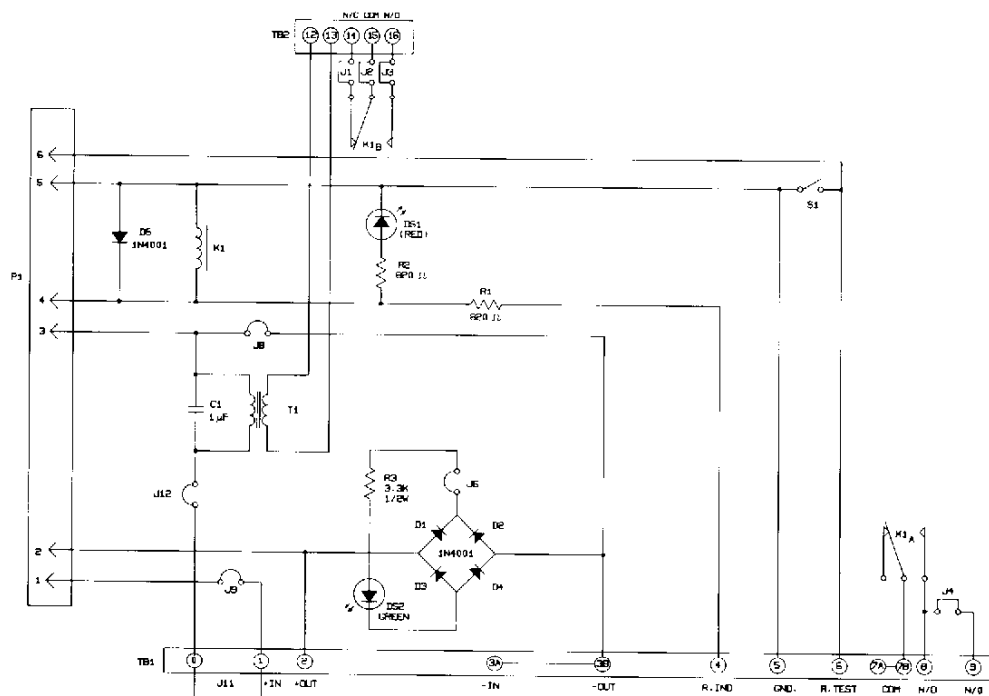

609U21

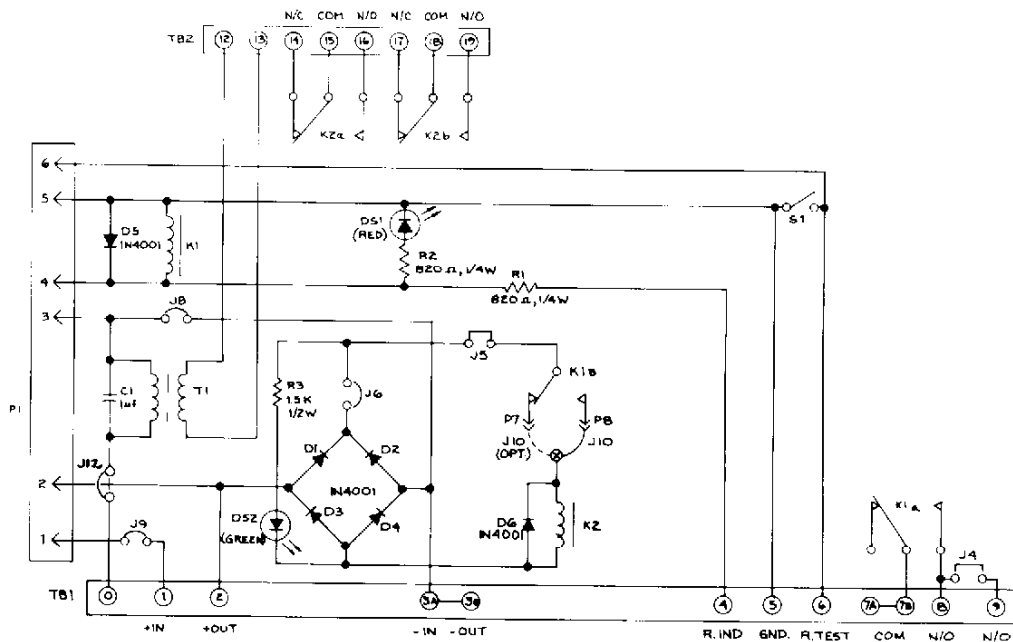

609U22/609U25

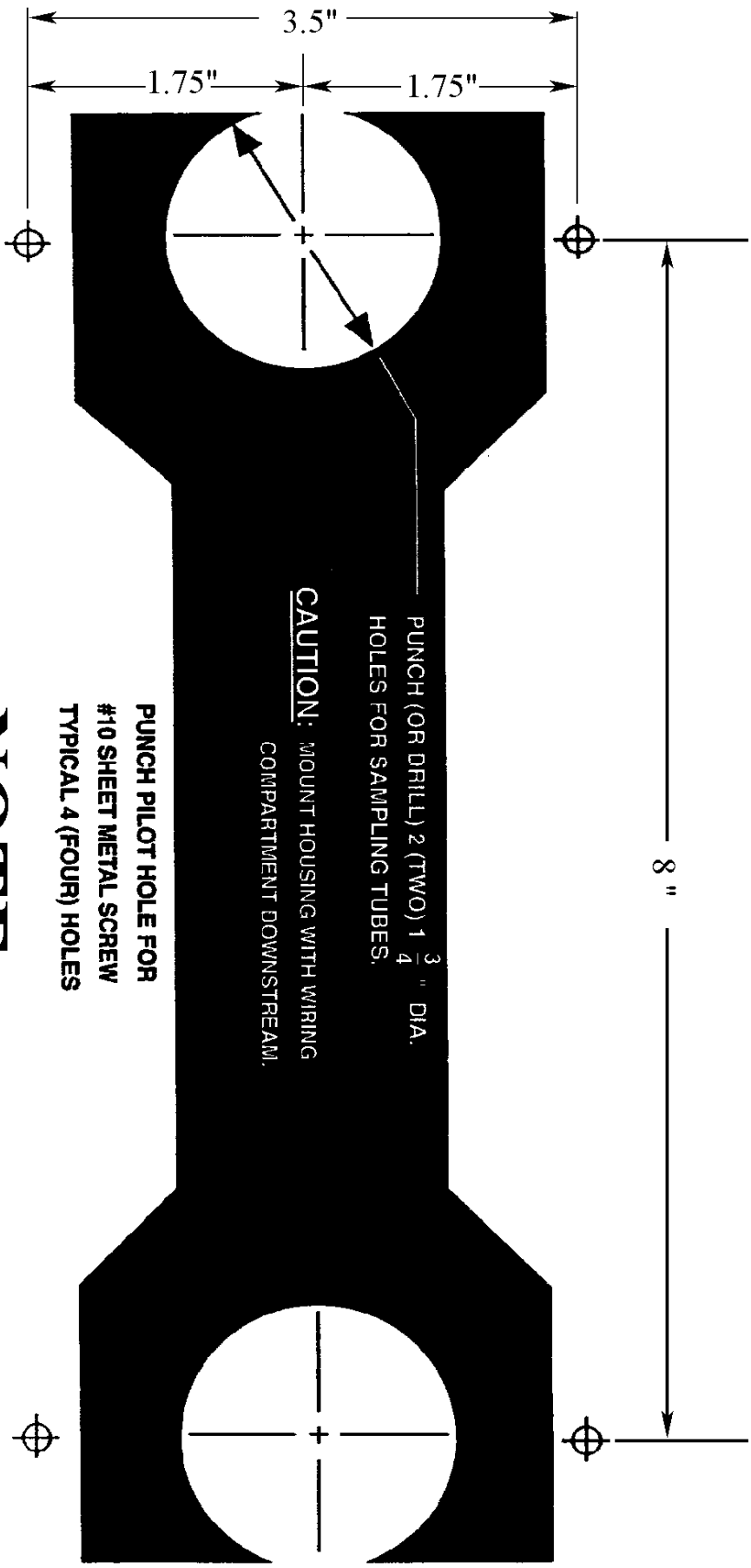

NOTE:

Do not use as actual template unless measurements
have been verified. Accuracy of dimensions can be
lost during fax transmissions.