

KTD-405/KTD-405A/KTD-405-2D Controller Keypad
User Manual

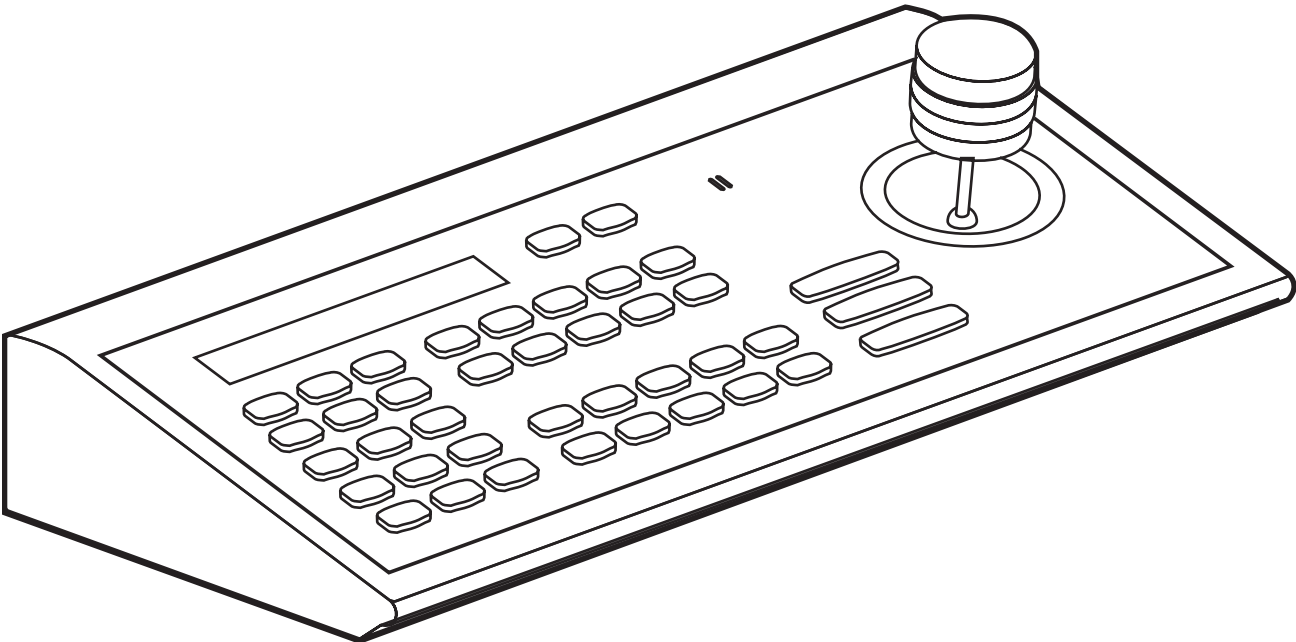

Copyright © 2009, GE Security, Inc.

This document may not be copied in whole or in part, or otherwise reproduced except as specifically permitted under US copyright law, without the prior written consent from GE.

Document number/revision: 1036547G.

Disclaimer The information in this document is subject to change without notice. GE, in keeping pace with technological advances, is a company of product innovation. Therefore, it is difficult to ensure that all information provided is entirely accurate and up-to-date. GE accepts no responsibility for inaccuracies or omissions and specifically disclaims any liabilities, losses, or risks, personal or otherwise, incurred as a consequence, directly or indirectly, of the use or application of any of the contents of this document.

This publication may contain examples of screen captures and reports used in daily operations. Examples may include fictitious names of individuals and companies. Any similarity to names and addresses of actual businesses or persons is entirely coincidental.

Trademarks and patents GE and the GE monogram are registered trademarks of General Electric.

Other trade names used in this document may be trademarks or registered trademarks of the manufacturers or vendors of the respective products.

Intended use Use this product only for the purpose for which it was designed; refer to the data sheet and user documentation. For the latest product information, contact your GE sales representative or visit us online at www.gesecurity.com.

FCC compliance This equipment has been tested and found to comply with the limits for a Class A digital device, pursuant to part 15 of the FCC Rules. These limits are designed to provide reasonable protection against harmful interference when the equipment is operated in a commercial environment. This equipment generates, uses, and can radiate radio frequency energy and, if not installed and used in accordance with the instruction manual, may cause harmful interference to radio communications.

You are cautioned that any changes or modifications not expressly approved by the party responsible for compliance could void the user's authority to operate the equipment.

EU directives **2004/108/EC (EMC directive).** Non-European manufacturers must designate an authorized representative in the Community. Our authorized manufacturing representative is GE Security, Kelvinstraat 7, 6003 DH Weert, Nederland.



2002/96/EC (WEEE directive). Products marked with this symbol cannot be disposed of as unsorted municipal waste in the European Union. For proper recycling, return this product to your local supplier upon the purchase of equivalent new equipment, or dispose of it at designated collection points. For more information, visit www.recyclethis.info.

Contents

Preface	1
Conventions used in this document	1
Safety terms and symbols	1
Chapter 1. KTD-405/405A/405-2D overview	3
Product overview	4
Product contents	4
Operating modes	5
Digiplex mode	5
Zone mode	6
Chapter 2. Installation	7
Installation guidelines	8
Back panel connections	10
KTD-405/KTD-405-2D connections	10
KTD-405A connections	11
I/O box connections	12
RJ-cable connections	12
Twisted-pair connections	13
Connecting a multiplexer or DVMRe and domes	14
Connecting multiple keypads with RJ45 cables	15
Connecting multiple keypads with STP cable	16
Connecting new and old I/O boxes	17
Setting audio attenuation	18
Chapter 3. Programming	19
Programming modes	20
Entering programming modes	21
Supervisor programming	22
User programming	28
Standard Digiplex menus	28
Zone menus	31
Remote programming	34
Quick Shadow Tour 1 programming short cut	35

Chapter 4.	Operation	37
	Operating your keypad	38
	Standard Digiplex mode	41
	Selecting a monitor	41
	Selecting a camera	41
	Controlling a camera	42
	Setting a preset	42
	Recalling a preset	43
	Operating group switching on Digiplex IV switchers	43
	Setting autopan limits	44
	Controlling a DVMRe/multiplexer (hybrid mode)	44
	Controlling a recording device	45
	System information menus	46
	Help menu	46
	Audio	47
	Zone mode	48
	Programming a DVMRe/multiplexer camera sequence	51
Chapter 5.	Troubleshooting and support	53
	Troubleshooting your keypad	54
	Contacting us	56
	Online resources	56
Appendix A.	Sample configurations and charts	57
	Sample analog system configurations	58
	Old I/O box connections	61
	Connecting multiple keypads to the old I/O box	63
	Sample IP system configuration	64
	Receiver site addressing	65
	Reprogrammable keys and commands	67
	System planning chart	69
Index		71

Preface

This is the *GE KTD-405/KTD-405A/KTD-405-2D Controller Keypad User Manual*. This document includes an overview of the product and detailed instructions explaining:

- how to install a KTD 405/KTD-405A/KTD-405-2D keypad; and
- how to program and operate a KTD-405/KTD-405A/KTD-405-2D keypad.

There is also information describing how to contact technical support if you have questions or concerns.

To use this document effectively, you should have the following minimum qualifications:

- a basic knowledge of CCTV systems and components; and
- a basic knowledge of electrical wiring and low-voltage electrical connections.

Read these instructions and all ancillary documentation entirely before installing or operating this product. The most current versions of this and related documentation may be found on our website. Refer to [Online resources](#) on page 56 for instructions on accessing our online publication library.

Note: A qualified service person, complying with all applicable codes, should perform all required hardware installation.

Conventions used in this document

The following conventions are used in this document:

Bold	Menu items and buttons.
<i>Italic</i>	Emphasis of an instruction or point; special terms.
	File names, path names, windows, panes, tabs, fields, variables, and other GUI elements.
	Titles of books and various documents.
<i>Blue italic</i>	(Electronic version.) Hyperlinks to cross-references, related topics, and URL addresses.
Monospace	Text that displays on the computer screen.
	Programming or coding sequences.

Safety terms and symbols

These terms may appear in this manual:



CAUTION: *Cautions* identify conditions or practices that may result in damage to the equipment or other property.



WARNING: *Warnings* identify conditions or practices that could result in equipment damage or serious personal injury.

Chapter 1 KTD-405/405A/405-2D overview

This chapter provides an explanation of the conventions in this document and an overview of your keypad.

In this chapter:

<i>Product overview</i>	4
<i>Operating modes</i>	5

Product overview

GE Security’s KTD-405 is compatible with all GE Security products including DVMRs, multiplexers, matrix switchers, alarm interfaces, CyberDomes, and Digiplex systems. The KTD-405 can select and switch video, initiate camera tours, and select monitors.

The KTD-405A adds audio functionality to the unit, providing two-way voice communication with a built-in speaker, amplifier, and audio microprocessor for automatic volume level.

Product contents

The KTD-405 (*Figure 1*) and KTD-405A (*Figure 2*) packages, in addition to the items shown, include this *KTD-405/KTD-405A/KTD-405-2D Controller Keypad User Manual (1036547)* and a quick reference guide (*1047307*). The KTD-405-2D (not shown) is similar to the KTD-405, but with a 2-axis joystick instead of a 3-axis joystick.

Figure 1. KTD-405 package contents



Figure 2. KTD-405A package contents

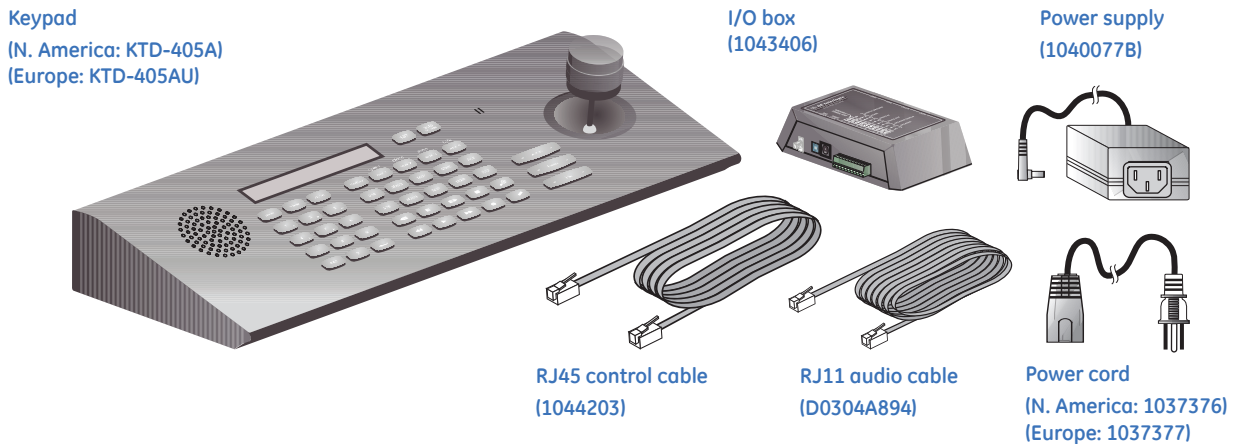

Inspect the package and contents for visible damage. If any components are damaged or missing, do not use the unit; contact the supplier immediately. If you need to return the unit, you must ship it in the original box.

Operating modes

The KTD-405 can be programmed to operate in two modes: standard Digiplex® or zone (DVMR/multiplexer/PTZ control). (See *Appendix A, Sample configurations and charts* for layout samples of these modes.)

Note: Be aware that the addressing between domes and multiplexers is offset. When setting up and controlling your cameras in zone mode, refer to *Receiver site addressing* on page 65.

Digiplex mode

Digiplex mode can be divided into two categories: *standard Digiplex mode* and *hybrid Digiplex mode*.

Standard Digiplex mode. In *standard Digiplex mode*, the system's main switching device is a standard matrix switcher. The keypad can address and control PTZ receiver sites, operate a matrix switcher with 128 monitor outputs, address and select views from 32 multiplexers, operate up to 32 recorders, and manage access control points.

Note: The keypad can address and control 1599 PTZ's using the RS485 and 1023 PTZ's using RS422. Independent permissions can be set for 1023 PTZ cameras.

Hybrid Digiplex mode. You can also operate a DVMRe/multiplexer when operating in a *hybrid Digiplex mode*. This enables the DVMRe or multiplexer to provide multiscreen views by connecting the output of the unit to an input on the matrix switcher. Digiplex mode (standard or hybrid) does not require that the DVMRes have dedicated monitors. If you are using Calibur™ units, they must be connected to the keypad's RS-485 control signal; other brands must be connected to the keypad's RS-422 control signal using a KTD-93 interface. When you press the zone key, the keypad switches to zone mode operation (hybrid Digiplex mode), which enables it to control the DVMRe/multiplexer (right display in *Figure 3*). If the zone is assigned to a camera input on the matrix switcher (done in programming), when you select the zone, the keypad sends a command to the matrix switcher to call up the assigned input on the active monitor.

While in hybrid Digiplex mode, key functions are the same as those used during normal zone mode operation, except the **esc** key, which returns the keypad to standard Digiplex mode of operation.

Note: Camera control (PTZ) is disabled while in hybrid mode

Figure 3. LCD menus showing standard and hybrid modes

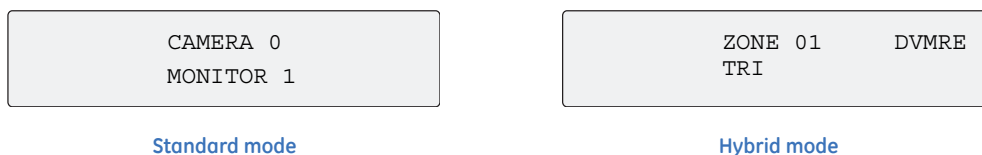

Zone mode

A zone is a remote switching device (multiplexer or DVMRe) that serves a group of cameras. A system can be divided into as many as 32 independent zones, and each zone can have from 1 to 64 cameras (average Zone size is 32, only Matrix switcher supports 64 and is less commonly used) depending on the type of controlling device. In addition, up to 250 zones can be controlled if all units from 33 to the maximum can use exactly the same setup parameters as unit 32.

The outputs from the zone's switching device connect to dedicated monitors directly. Each zone is assigned a device type (multiplexer or DVMRe) and a size (1 to 32 cameras) and can be assigned a 15-character name.

To call up a camera in a zone, you must know the zone number and the camera number (*Figure 4*). Refer to [Receiver site addressing](#) on page 65.

Figure 4. LCD display of zone mode

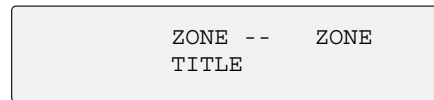

Chapter 2 Installation

This chapter shows all the connections you'll need to make to get your keypad and all the peripheral devices working within a diverse video surveillance network.

In this chapter:

- Installation guidelines* 8
- Back panel connections* 10
- I/O box connections* 12

Installation guidelines

Plan your system's camera and device assignments before installing the system. To help plan your system, use the *System planning chart* on page 69. And when installing your KTD-405 keypad, follow these guidelines:

- Each keypad requires its own I/O box. You can connect multiple I/O boxes to each other (using the RS485 control signals) to establish multiple keypads for controlling one system. For systems that are more complicated than are diagrammed in these instructions, contact GE Technical Support for assistance. (See *Contacting us* on page 56.)
- The keypad will not support hooking all connections at once to all keypads in a network. I.E. an installer can not connect the RS485 and RS422 ports to each keypad I/O box like a daisy chain. The keypad can support only one network back bone at a time, either all keypads connected to RS485 with external RS422 devices connected to the RS422 or a RS422 back bone with RS485 devices connected to the individual RS485.
- The audio and speaker connections are used only with a KTD-405A.
- Observe polarity when installing the RS-422 and RS-485 cables as well as the 12 VDC power supply (if you are not using the provided transformer with positive polarity center plug).
- The keypad itself is not grounded.
- Grounding the I/O box is optional, but it does provide some additional protection against equipment damage due to power surges caused by electrical storms.
- There must be no current in the shield of shielded cables. Maintain an open circuit (noncontinuous path) for the shield and hold it at the earth ground potential by grounding it at only one location.
- You can connect the RS-485 shield of individual cable segments to each other, but to nothing else. You will still ground the resulting shield circuit at one location only, despite the number of shield junctions.
- Each electrical circuit (RS-485 segment) must be biased. If keypads reside on separate electrical circuits (separated by fiber or Ethernet bridges, for example), then more than one keypad might have the bias switch set to ON (one for each circuit).
- The bias is sensitive to the polarity of the 12 VDC supply. If polarity on the power line is reversed, the keypad will not be damaged, but biasing will not operate correctly.
- Each electrical segment being terminated must be terminated at each end with bias turned on at one location only. Termination is generally required for the first and last device on a longer line. The termination switches are located within or on the devices themselves (keypads and cameras). Refer to the devices' manuals for termination requirements and methods.
- An electrical segment for biasing and termination considerations may consist of several wire runs and devices. For example, in *Figure 65* on page 60 there is only one electrical segment even though there are several pieces of wire and several devices.
- The installation of the KTD-405 is designed to work at the head end of a RS422 Digiplex or a RS485 GE/Impac system, so care should be taken to keep only one RS485 network and one RS422 network in a large system. The RS422 network must be made into a Digiplex wheel or loop to properly support RS422 serial Alarm annunciation and clearing.

Note: The keypads ship with an updated I/O box that provides RJ45 ports for the RS-485 data line and an RJ11 port for audio. See [Connecting new and old I/O boxes](#) on page 17 for connections between the new and old I/O boxes. For connection details for the old I/O boxes, see [Old I/O box connections](#) on page 61.

Table 1. Recommended cable types

Signal	Cable ¹	Minimum Size	Length/Feet	Length/Meters
RS-485	STP (shielded twisted-pair)	22 AWG	3,000	900
RS-422	UTP (unshielded twisted-pair)	22 AWG	10,000	3,000
Audio	STP (shielded twisted-pair)	18 AWG	500	150

1. Refer to the devices' manuals for specific cabling requirements.

Back panel connections

KTD-405/KTD-405-2D connections

Adhere to all installation guidelines while making connections, including your local codes and those provided in *Installation guidelines* on page 8.

Figure 5. KTD-405/KTD-405-2D back panel connections

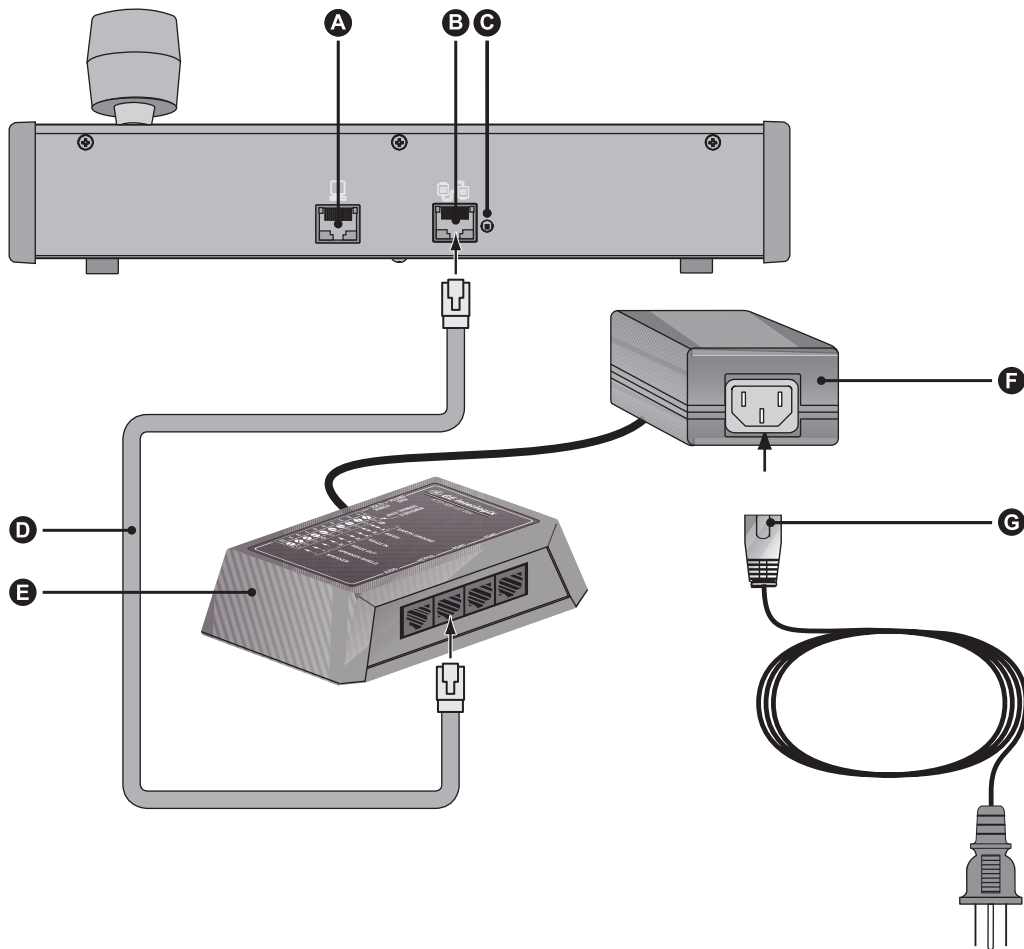

- A** RS-232 programming port (future use)
- B** RS-485 and RS-422 in/out
- C** RS-485 termination switch

- D** RJ45 control cable (GE equipment uses two different RJ45 cables. You must use the RJ45 cable provided with the unit.)

- E** I/O box
- F** Power supply
- G** Power cord

KTD-405A connections

Adhere to all installation guidelines while making connections, including your local codes and those provided in *Installation guidelines* on page 8.

Figure 6. KTD-405A back panel connections

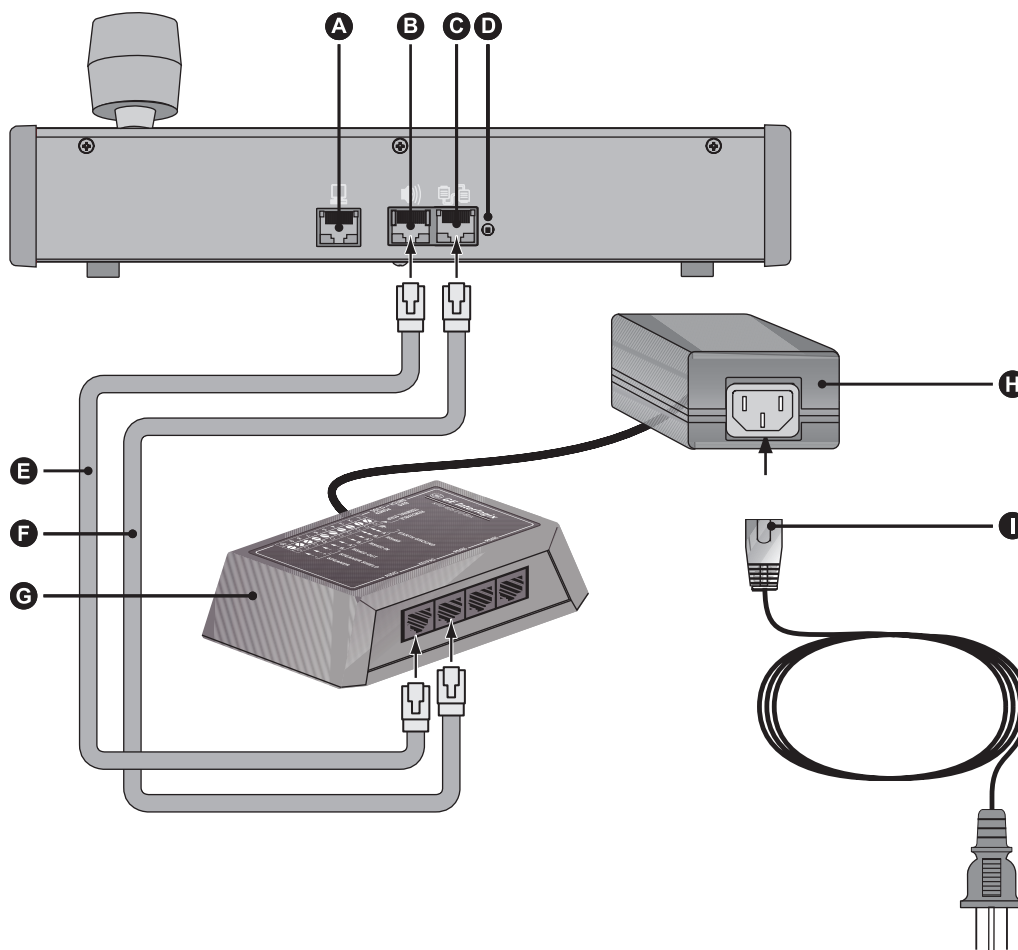

- A** RS-232 programming port (future use)
- B** Audio port
- C** RS-485 and RS-422 in/out
- D** RS-485 termination switch

- E** RJ11 audio cable
- F** RJ45 control cable (GE equipment uses two different RJ45 cables. You must use the RJ45 cable provided with the unit.)

- G** I/O box
- H** Power supply
- I** Power cord

I/O box connections

RJ-cable connections

The RJ-cable connections make new installations or additional devices easy to connect. If you are replacing an old phone-style I/O box in an existing installation, you can use the existing twisted-pair wires (STP for RS-485 and UTP for RS-422), if desired. See *Twisted-pair connections* on page 13.

Adhere to all installation guidelines while making connections, including your local codes and those provided in *Installation guidelines* on page 8.

Figure 7. RJ-cable connections to the I/O box

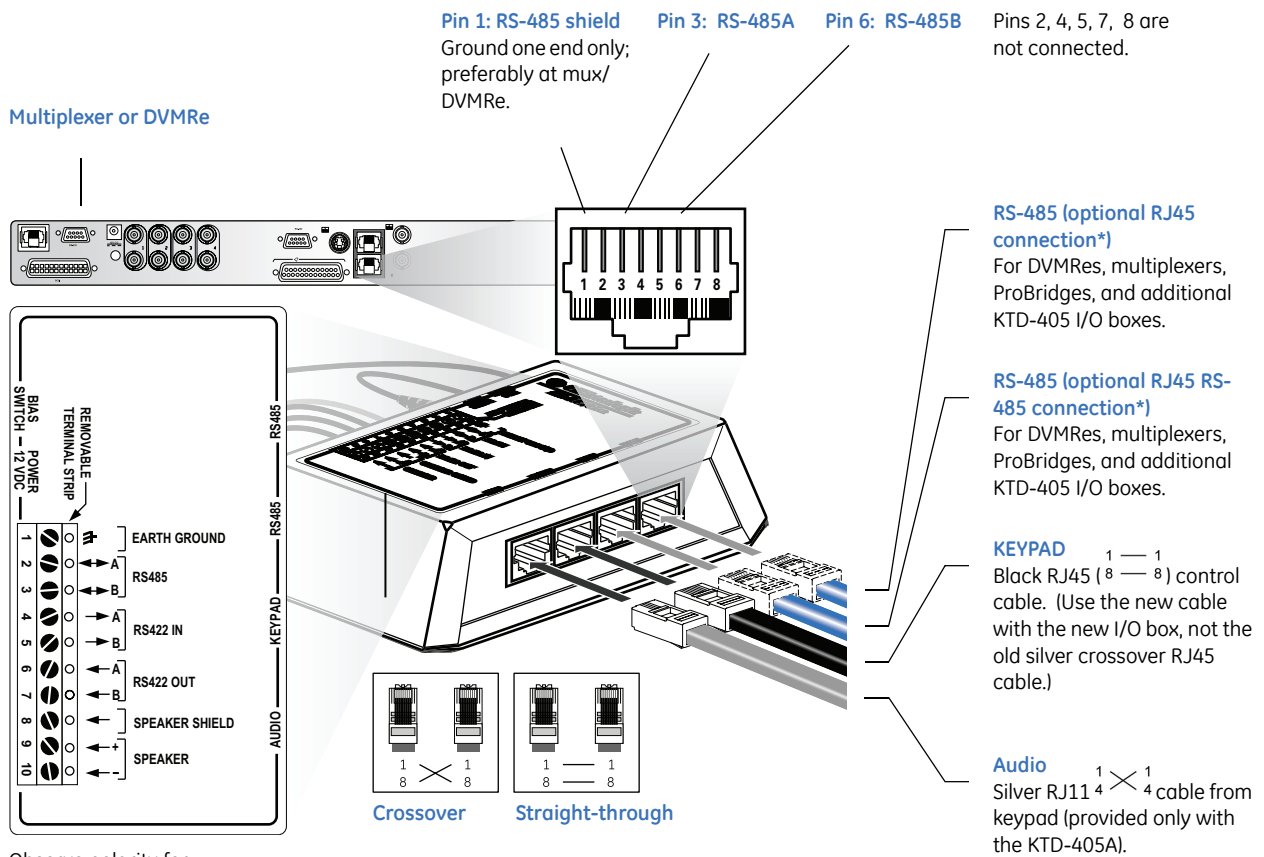

Observe polarity for:

- audio
- RS-422
- RS-485
- 12 VDC power. Transformer must have a positive center-polarity plug $\ominus \text{---} \bullet \text{---} \oplus$

Note: When using multiple keypads, you can connect CyberDomes and other receivers to the RS-422 output from any keypad.

* The installer supplies the optional RJ45 RS-485 cables with the stated pinouts (an RS-485 connection is also available on the terminal strip).

Twisted-pair connections

The twisted-pair connections are available to connect additional devices or for existing installations where individual wires were used to connect to the old phone-style I/O box. Easy-to-use RJ-cable connections are also available on the new I/O box. See *RJ-cable connections* on page 12.

Adhere to all installation guidelines while making connections, including your local codes and those provided in *Installation guidelines* on page 8.

Figure 8. Wire connections to the I/O box

Bias switch

The bias switch maintains an appropriate load on the RS-485 line. Set the bias switch to ON for one keypad in a typical system (any one keypad and only one keypad). If your system is divided into groups that are separated by fiber or Ethernet bridges, you must set the bias switch to ON for one keypad in each group.

Tie-wrap

For safety, use a tie-wrap to secure the power cable to the tie-in.

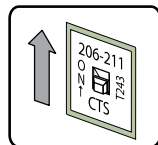
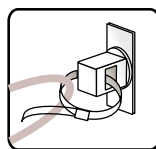

12 VDC power

(12 VDC transformer must have a positive center polarity plug)

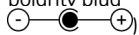

Earth ground (to ground)

RS-485 connection*

RS-422 IN (from keypad or alarm unit, if used)

RS-422 OUT (to switcher or cameras)

Speaker/shield (to remote speaker, if used)

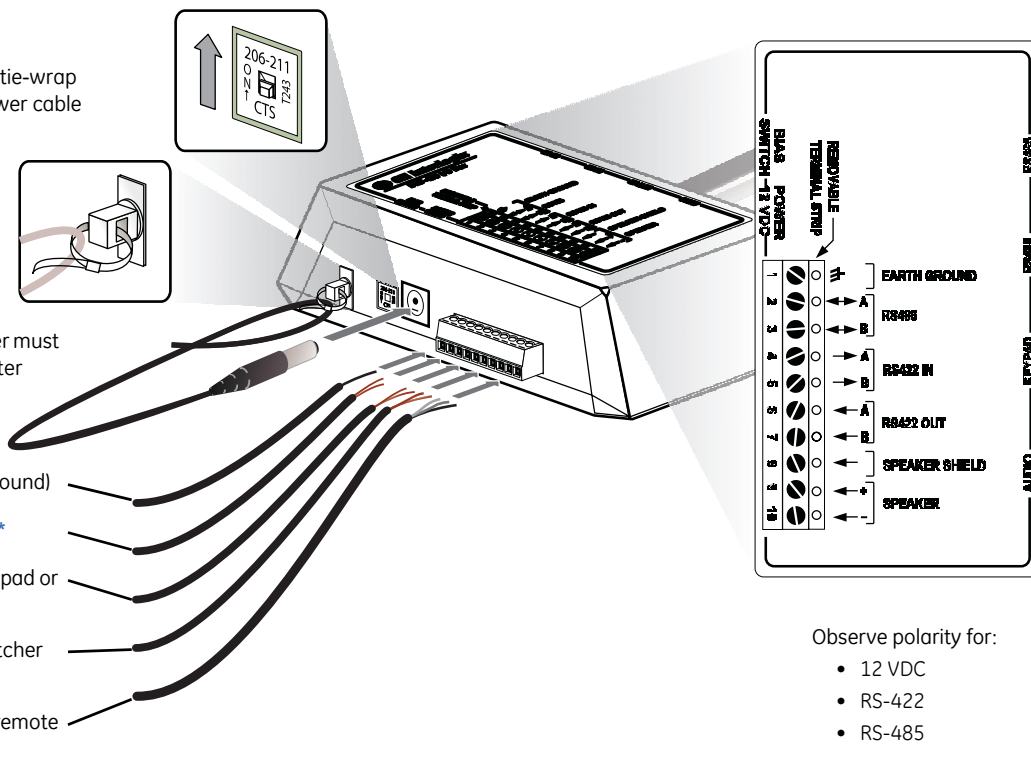

Observe polarity for:

- 12 VDC
- RS-422
- RS-485

* For mux, DVMRe, or additional keypad I/O box. (RS-485 connections are also available with the RJ45 connectors.)

Connecting a multiplexer or DVMRe and domes

Adhere to all installation guidelines while making connections, including your local codes and those provided in *Installation guidelines* on page 8.

Figure 9. Connecting a keypad (KTD-405 shown) to a multiplexer or DVMRe (shown) and domes

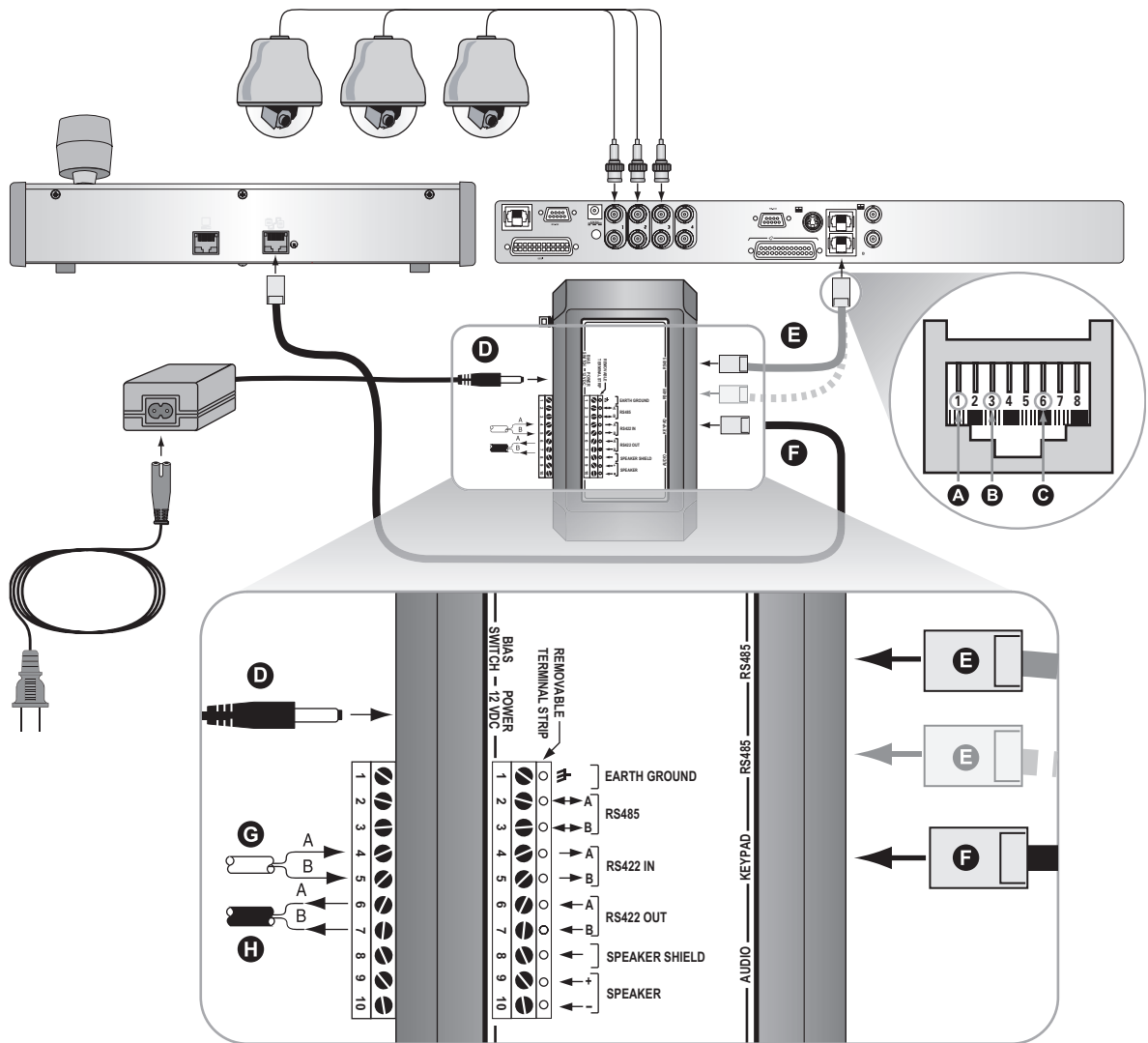

- A** PIN 1 to RS-485 shield (ground one end only)
- B** PIN 3 to RS-485 A
- C** PIN 6 to RS-485 B. (Pins 2, 4, 5, 7, and 8 are not connected.)
- D** 12 VDC (observe polarity, if provided transformer not used)
- E** RS-485 OUT (data out to devices such as multiplexers or DVMRe's; ground at mux/DVMRe)
- F** KEYPAD IN (RS-422 and RS-485 data in from keypad; RS-422 data and power out to keypad)
- G** RS-422 IN (data in from devices such as alarm units, ASCII converters, or keypads (see guidelines))
- H** RS-422 OUT (data out to devices such as domes, switchers, or keypads (other than KTD-405s))

Connecting multiple keypads with RJ45 cables

Adhere to all installation guidelines while making connections, including your local codes and those provided in *Installation guidelines* on page 8.

Figure 10. KTD-405, KTD-405-2D, and KTD-405A connections via RJ45 cables

Observe polarity for:

- audio
- RS-422
- RS-485
- 12 VDC power. Transformer must have a positive center-polarity plug 

Note: When using multiple keypads, you can connect CyberDomes and other receivers to the RS-422 output from any keypad. Only one RS communication can be chained together, if both are hooked up on 405 I/O boxes then performance will degrade or it will not work at all.

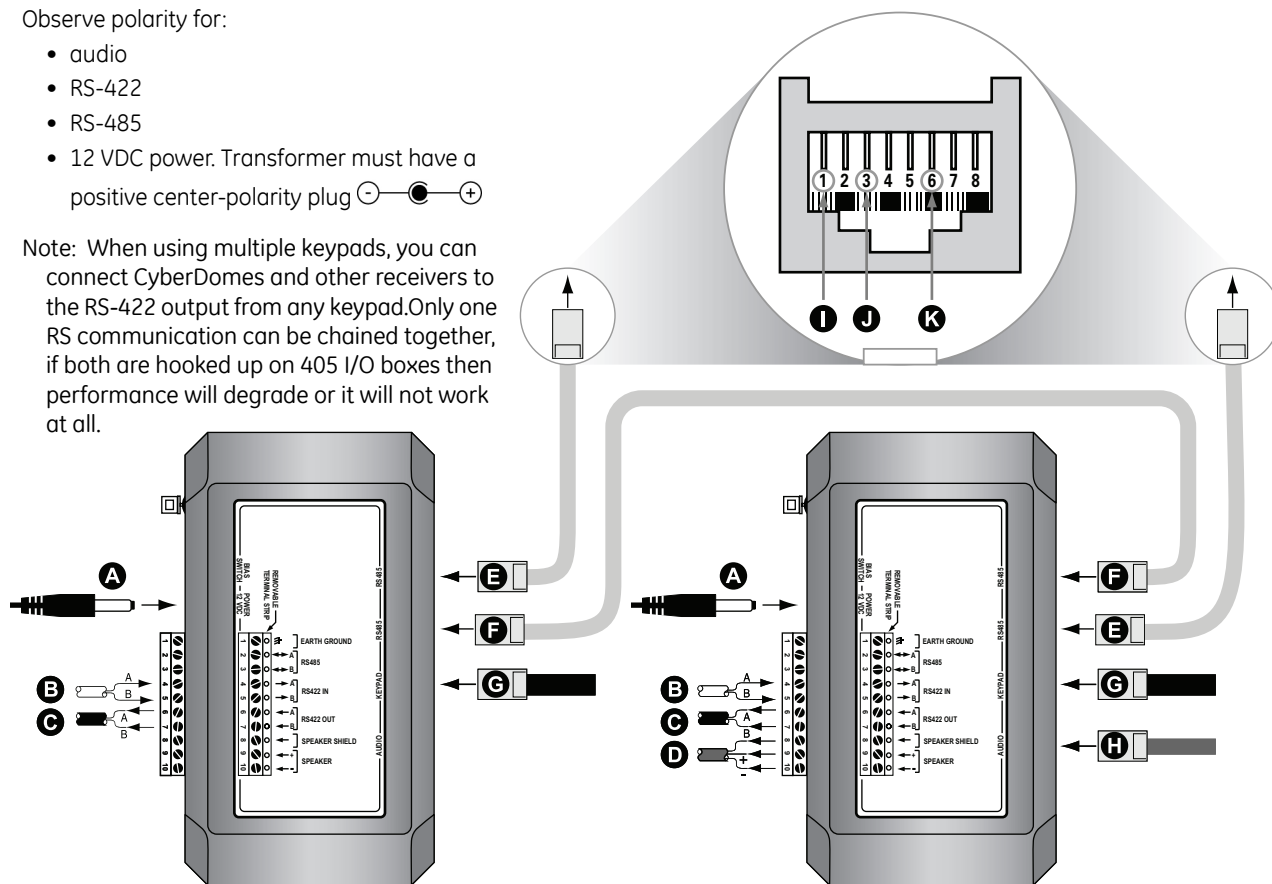

- A** 12 VDC (observe polarity, if provided transformer and plug not used)
- B** RS-422 IN (data in from devices such as alarm units, ASCII converters, or keypads (see guidelines))
- C** RS-422 OUT (data out to devices such as domes, switchers, other keypads (not KTD-405s))
- D** AUDIO OUT (to speaker and speaker shield)
- E** RS-485 OUT (data out to devices such as multiplexers or DVMRes; ground at mux/DVMRe)
- F** RS-485 to I/O box of additional keypad via RJ45 cable
- G** KEYPAD IN (RS-422 and RS-485 data in from keypad; RS-422 data and power out to keypad)
- H** AUDIO IN (from keypad)
- I** PIN 1 to RS-485 shield (ground one end only)
- J** PIN 3 to RS-485 A
- K** PIN 6 to RS-485 B (PINS 2, 4, 5, 7, and 8 are not connected.)

Connecting multiple keypads with STP cable

Adhere to all installation guidelines while making connections, including your local codes and those provided in *Installation guidelines* on page 8

Figure 11. KTD-405 and KTD-405A connections via STP cables

Observe polarity for:

- audio
- RS-422
- RS-485
- 12 VDC power. Transformer must have a positive center-polarity plug $\ominus \text{---} \bullet \text{---} \oplus$

Note: When using multiple keypads, you can connect CyberDomes and other receivers to the RS-422 output from any keypad. Only one RS communication can be chained together, if both are hooked up on 405 I/O boxes then performance will degrade or it will not work at all.

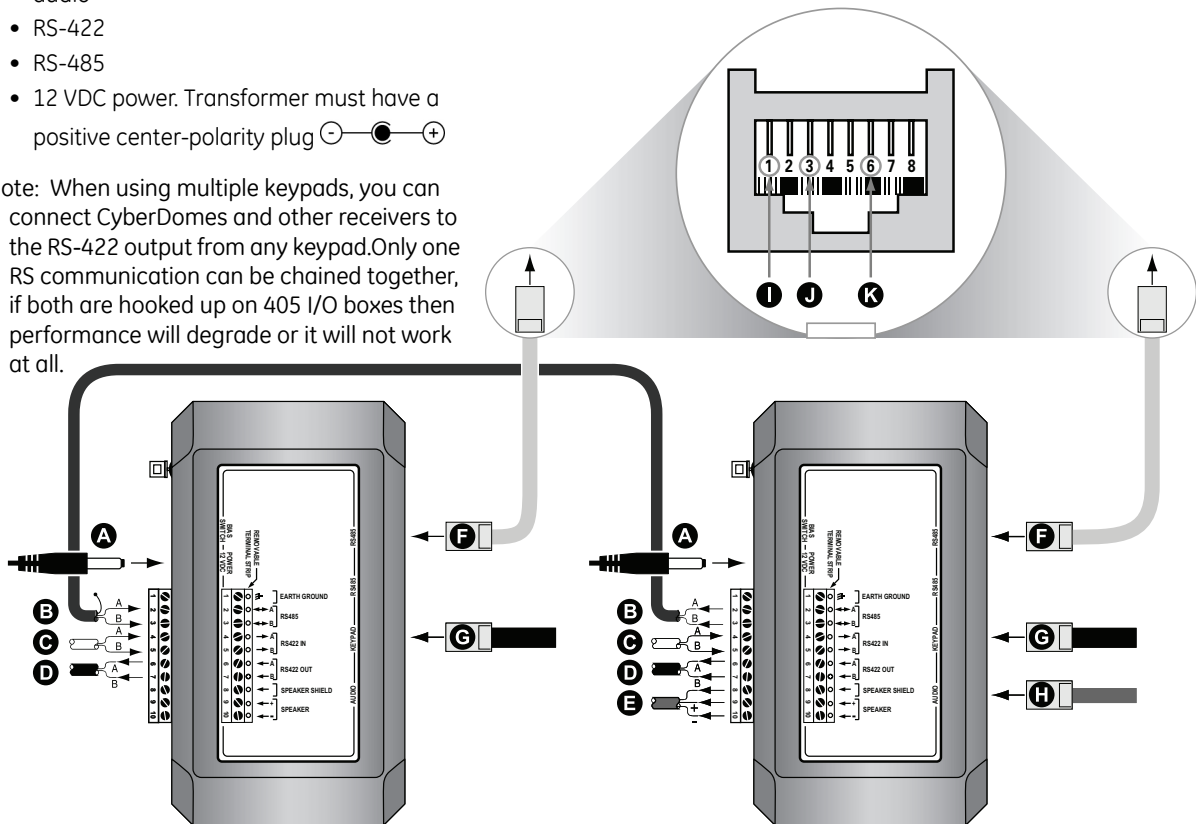

- A** 12 VDC (observe polarity, if provided transformer and plug not used)
- B** RS-485 to I/O box of additional keypad via STP cable (with floating shield)
- C** RS-422 IN (data in from devices such as alarm units, ASCII converters, or keypads (see guidelines))
- D** RS-422 OUT (data out to devices such as domes, switchers, other keypads (not KTD-405s))
- E** AUDIO OUT (to speaker and speaker shield)
- F** RS-485 OUT (data out to devices such as multiplexers or DVMRe's; ground at mux/DVMRe)

Note: When using STP for the RS-485 connection between I/O boxes, you can use only one of the two RJ45 RS-485 OUT connections to a multiplexer or DVMRe. This ensures proper termination.

- G** KEYPAD IN (RS-422 and RS-485 data in from keypad; RS-422 data and power out to keypad)
- H** AUDIO IN (from keypad)
- I** PIN 1 to RS-485 shield (ground one end only)
- J** PIN 3 to RS-485 A
- K** PIN 6 to RS-485 B (PINs 2, 4, 5, 7, and 8 are not connected.)

Connecting new and old I/O boxes

Adhere to all installation guidelines while making connections, including your local codes and those provided in *Installation guidelines* on page 8.

Note: For additional connection details about the old I/O boxes, see *Appendix D. Old I/O Box Connections*.

Figure 12. New to old I/O box connection

Observe polarity for:

- audio
- RS-422
- RS-485
- 12 VDC power. Transformer must have a positive center-polarity plug $\ominus - \bullet - \oplus$

Note: When using multiple keypads, you can connect CyberDomes and other receivers to the RS-422 output from any keypad. Only one RS communication can be chained together, if both are hooked up on 405 I/O boxes then performance will degrade or it will not work at all.

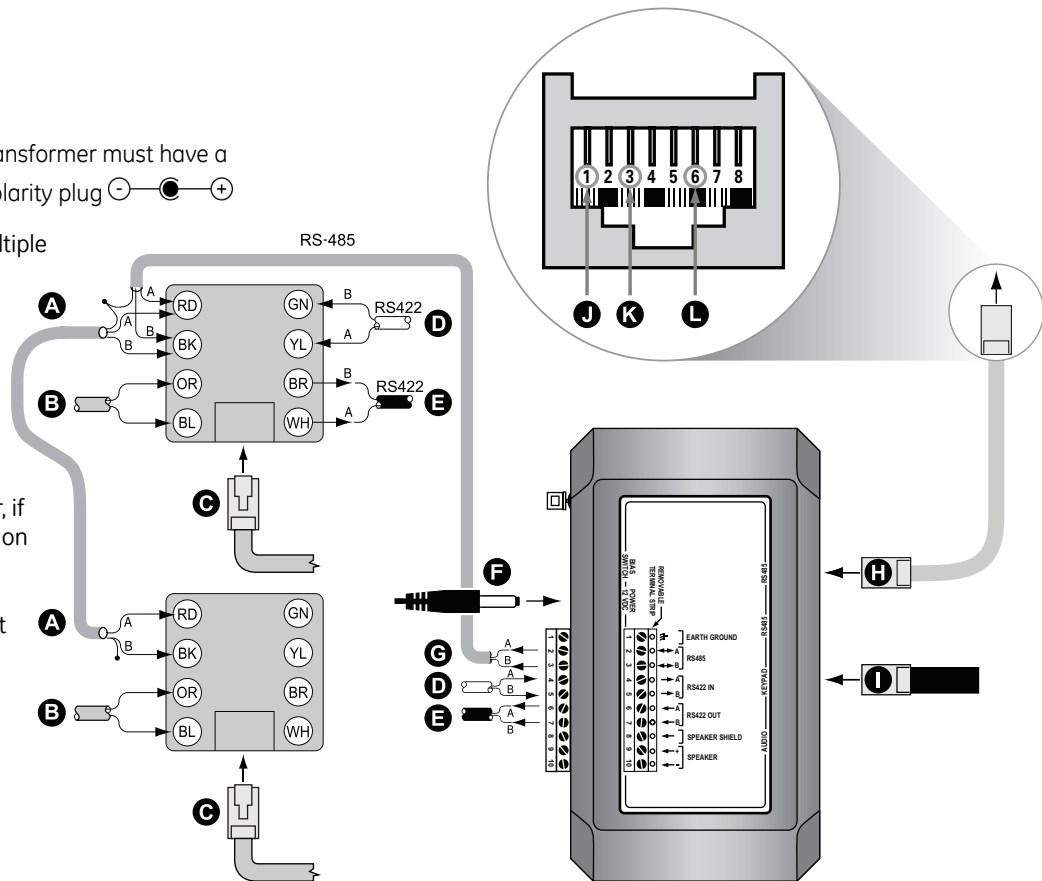

- A** RS-485 shield (float)
- B** 12 VDC (no polarity on old I/O box)
- C** RJ45 from keypad (RS-422 data in from keypad; silver crossover cable for old I/O box)
- D** RS-422 IN (data in from devices such as alarm units, ASCII converters, or keypads (see guidelines))
- E** RS-422 OUT (data out to devices such as domes, switches, or keypads (other than KTD-405s))
- F** 12 VDC (observe polarity on new I/O box)
- G** RS-485 to I/O box of additional keypad
- H** RS-485 OUT (data out to devices such as multiplexers or DVMRes; ground at mux/DVMRe)
- I** KEYPAD IN (RS-422 and RS-485 data in from keypad; black straight-through cable for new I/O box)
- J** PIN 1 to RS-485 shield (ground one end only)
- K** PIN 3 to RS-485 A
- L** PIN 6 to RS-485 B (PINS 2, 4, 5, 7, and 8 are not connected.)

Note: When using STP for the RS-485 connection between I/O boxes, you can use only one of the two RJ45 RS-485 OUT connections to a multiplexer or DVMRe. This ensures proper termination.

Setting audio attenuation

When using a KTD-336 audio converter, set the attenuation jumpers to the ON position (*Figure 13*). The attenuation jumpers are located on the audio/IO card, which is attached to the keypad's base plate. When not using an audio converter, leave the attenuation jumpers in their default OFF position.

Figure 13. Audio I/O board with attenuation jumpers

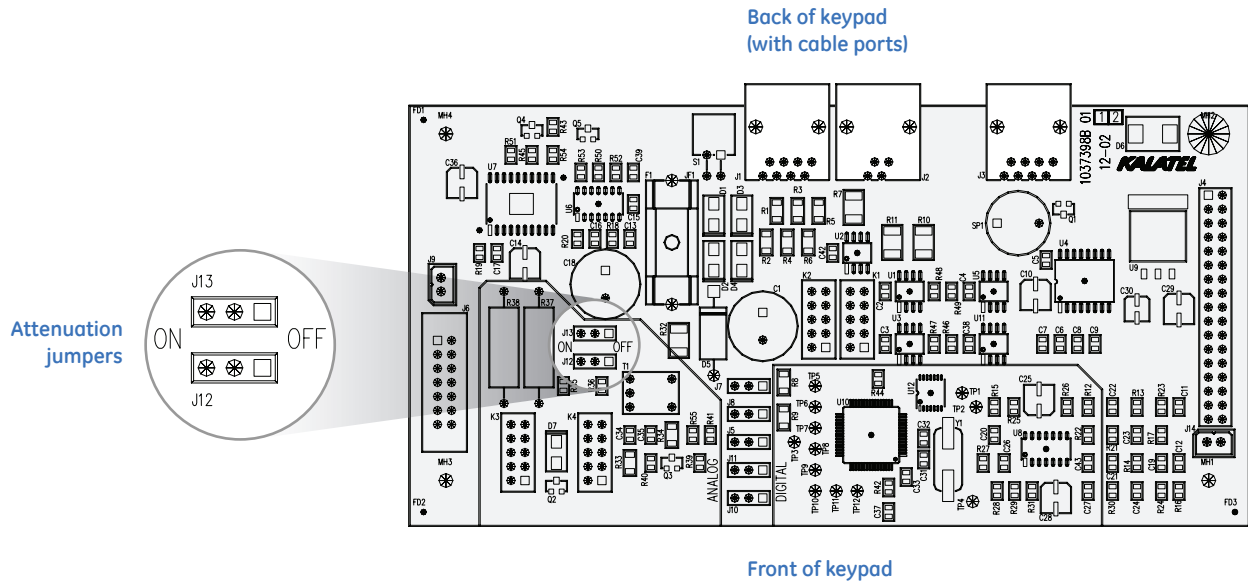

Chapter 3 Programming

This chapter explains the programming modes and goes through the various steps you'll need to follow to program your keypad.

In this chapter:

- Programming modes* 20
- Supervisor programming* 22
- User programming* 28
- Remote programming* 34

Programming modes

There are different programming modes for the keypad:

- **Supervisor programming mode:** Establishes such essentials as the keypad’s nonvolatile memory, title and many fundamental operating parameters, and allows flexible system setup.
- **User programming mode:** Establishes the keypad’s system architecture for operations.
- **Remote device programming mode:** Lets you program system devices such as cameras and VCRs.

Refer to the menu keys in *Figure 14* and the navigation keys in *Table 2* on page 20 while moving through the programming menus.

Figure 14. Menu keys (gray keys are available on the KTD-405A only)

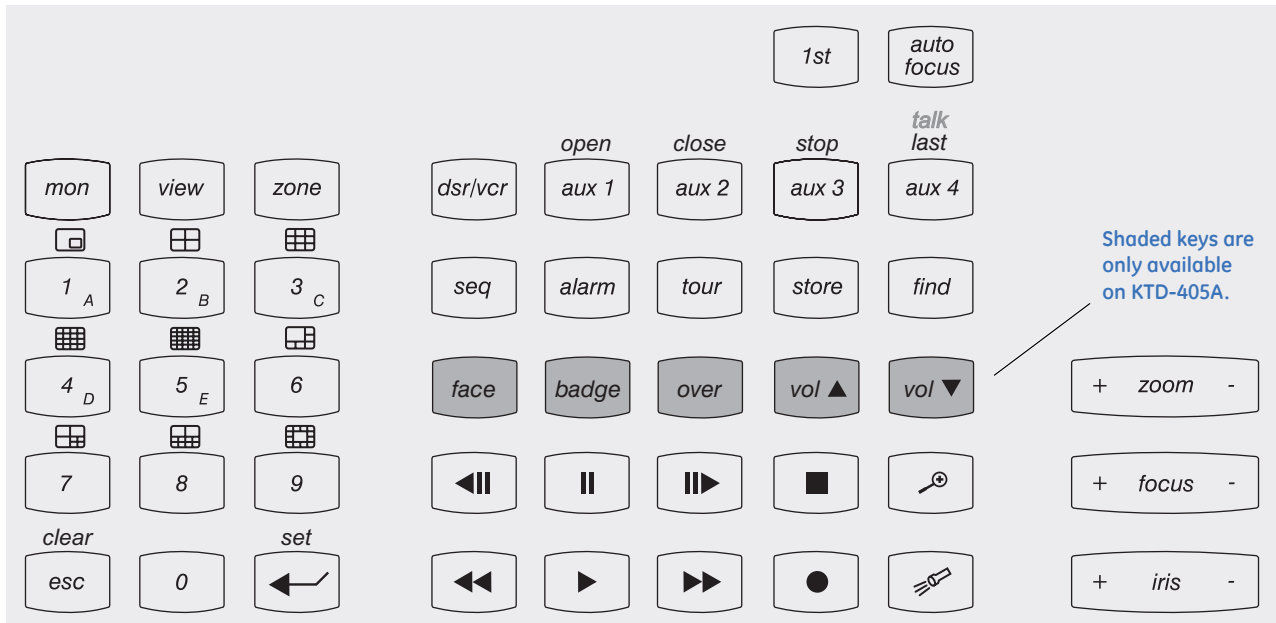

Table 2. Navigating the programming menus

Key	Function
▶▶	displays the next menu
◀◀	displays the previous menu
	scrolls up when indicated by ↑ in the menus
▶	scrolls down when indicated by ↓ in the menus
▶	scrolls right when indicated by → in the menus
◀	scrolls left when indicated by ← in the menus
Joystick	scrolls up, down, left, or right when indicated by ↑, ↓, ←, → in menus
seq	advances menus or exits menus if held for three seconds
1st	displays the previous menu

Entering programming modes

To enter programming mode, do the following:

1. When you provide power to the unit, the normal operating display appears (*Figure 15*).

Figure 15. Normal operating display

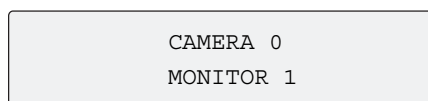

2. Press and hold the \leftarrow key until you hear a tone and see the *ENTER PROGRAMMING CODE* menu appears (*Figure 16*).

Figure 16. ENTER PROGRAMMING CODE menu

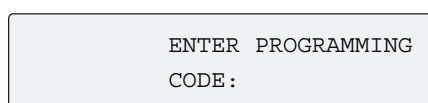

Note: The *ENTER PROGRAMMING CODE* menu times out after five seconds.

3. Enter your programming code:
 - Supervisor: Press **1-4-7-6-seq** and see [Supervisor programming](#) on page 22.
 - User: Press **5-7-9-seq** and see [User programming](#) on page 28.
 - Remote device: Press **9-5-1-seq** and see [Remote programming](#) on page 34.

Note: These access codes can be changed by the installer or administrator. They will tell you the new codes if you are allowed access to the menu. Menus time out after four minutes. Menus that were not implemented in this release are indicated by two beeps and a message that reads NOT IMPLEMENTED.

Supervisor programming

As explained in *Entering programming modes* on page 21, to enter the supervisor menus, from the *ENTER PROGRAMMING CODE* menu, press **1-4-7-6-seq.**

Note: This is the default factory supervisor programming code sequence. After you install your KTD-405 keypad, be sure to change the supervisor programming code as soon as possible to avoid security problems. To change the programming code, see *Figure 27* on page 26 of this menu. This is a critical number since it is needed to change any of the access codes. Be sure to store the new number in a safe place. If the number is lost, GE Security technical support can help you reset the keypad to factory defaults. All keypad setup information will be lost.

- At the first menu in supervisor programming mode, you have the option to erase the keypad’s nonvolatile memory and reload factory values. If you chose **YES**, you have these further options:

RESET ALL. Resets all stored settings to factory default.

RESET ALL BUT TITLES. Retains the zone titles, but sets everything else to factory defaults.

CAMERA. Access the camera you want to reset before you enter the supervisor programming. Selecting this will send a reset to the camera. This is for resetting or restarting GE PTZs, not for clearing settings. (16x, CyberDome2, and Legend)

Pressing **▶** forwards you through programming without changing set parameters.

To skip this menu and go to the next, press **-** or **▶**.

Figure 17. Supervisor programming menu tree

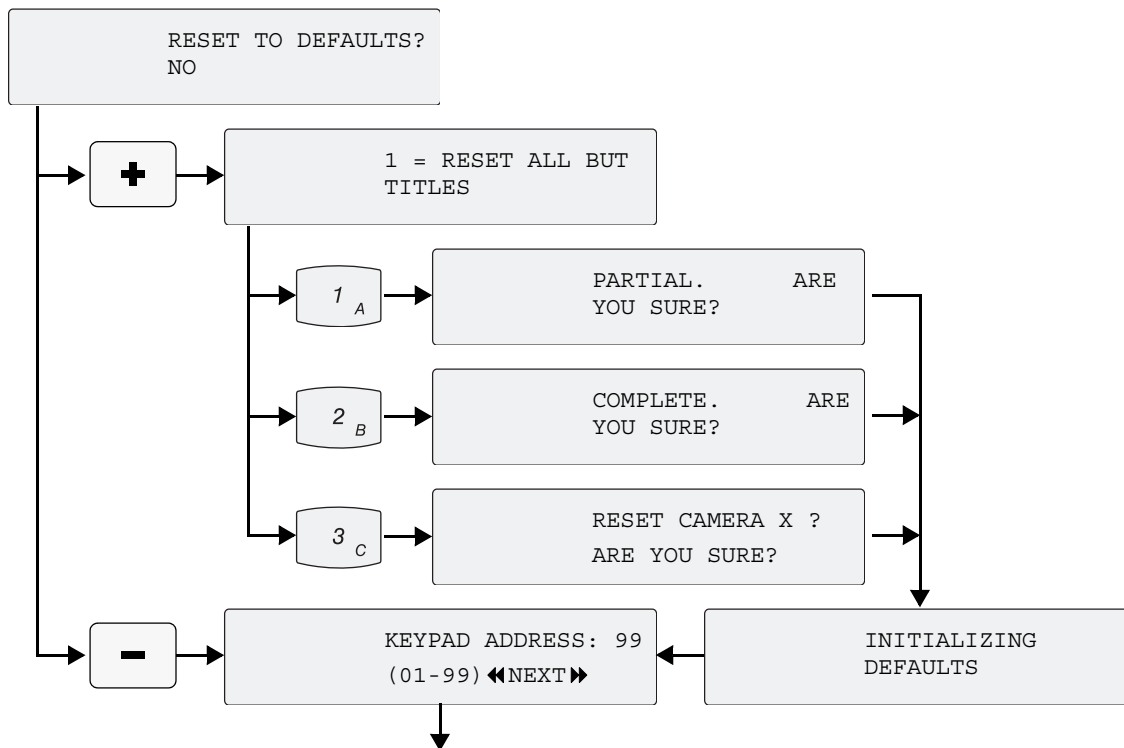

Note: All PTZ's that are capable will reset when you send this command.

- The keypad address screen is shown in *Figure 17* on page 22. A keypad address is a number from 1 to 254 that distinguishes a keypad from other devices. This address is automatically assigned (starting at 99 and proceeding downward in value) when the keypad is first connected into the RS-485 communication line. You can assign higher addresses manually. The address doesn't change unless you assign a new address or the system configuration changes. Enter a new keypad address or press ► to display the following menu (*Figure 18*).

Note: Entering an address that is already assigned displays a menu that reads ADDRESS ALREADY IN USE. Each Keypad uses a RS485 device ID to communicate in the RS485 serial network.

- The KB3 keypad uses an earlier version of the communication protocol. In most cases this menu setting will remain at the default value of **NO**. However, if the KTD-405 you are using in a system that needs to communicate PTZ commands to a Calibur CBR-KB3/J keypad or ProBridge, you may need to select **YES** so that the KTD-405 communicates properly with these devices.
- Enabling remote programming allows you to enter the **9-5-1-seq** code for programming remote devices in the system. If disabled, a tone sounds when you enter the **9-5-1-seq** code, but not the menu.
- Use the **||**, **▶**, **|||**, or **◀||** keys or move the joystick to title the keypad (*Figure 20*).

- ||** or **↑** Moves from a space to A through Z, to 9 through 0.
- ▶** or **↓** Moves from a space, to 0 through 9, to Z through A.
- |||** or **→** Moves the cursor right.
- ◀||** or **←** Moves the cursor left.

A keyboard title can be up to 14 characters. Titles can include A through Z, 0 through 9, and spaces.

Figure 18. KB3 PTZ PROTOCOL display

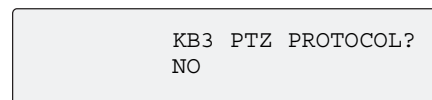

Figure 19. ENTER REMOTE PRGMG display

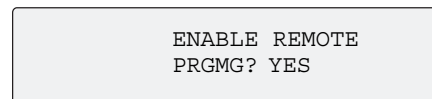
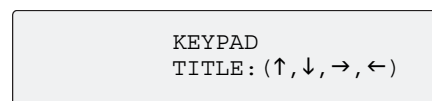

Figure 20. KEYPAD TITLE display



- The keypad lockout priority menu (*Figure 21*) allows the supervisor to set up a hierarchical relationship among keypads in the system so that keypads with a higher priority level can prevent other keypads with lower priority from interfering with PTZ control of cameras.

The default value is zero, which disables the priority lockout system functions for this keypad. It will ignore any lockout commands. Other values of priority, with 1 being the highest, activate the priority system. This priority lockout must be manually asserted. Once asserted, the lockout follows any change in camera selection until it times out.

Note: The keypads must all be connected to the same RS485 bus, or otherwise communicate with each other for this feature to work

The next display in *Figure 21*, which appears only if a lockout priority greater than zero is selected, allows you to adjust the timeout period for the priority lockout feature.

- The lowest user programmed preset designates the lowest number that users can assign as on-the-fly presets. All others are protected presets.

You can set all the PTZ presets (0 – 127) in the programming menus of the camera. Some presets can be set directly from the keypad. Some systems may require that certain presets remain constant, so be careful when you change these. The lowest user programmed preset defines which presets are protected and which can be set directly from the keypad. During normal operation, you can store any number greater than or equal to the lowest user programmed preset by pressing the **store** key and entering a two-digit preset number, then pressing **store** again.

Presets 58 through 61 work in combination with the *aux* keys to quickly store presets—**aux 1** is 58, **aux 2** is 59, **aux 3** is 60, and **aux 4** is 61. Use presets 62 and 63 to store autopan left and right limits using the **◀||** and **||▶** keys. You can store preset 0 (home position) only in the programming menus. These shortcuts are available without regard to the setting of the lowest user preset, unless it is set to 128. The value of the lowest user preset itself becomes a special shortcut location. You can store it by pressing **store** three times and recall it by pressing **find** twice.

By changing the lowest user programmed preset from the default 58 to a lower number, you can make more presets available to keypad users.

Note: Pressing **store** then one of the four *aux* buttons prompts you to press **store** again, which sets the quick store position. Pressing **find** then one of the four *aux* buttons recalls the quick store position.

Figure 21. KEYPAD LOCKOUT PRIORITY displays

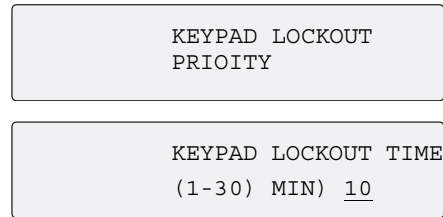

Figure 22. Lowest user programmed preset menu



Entering a new preset number or pressing **▶** will take you to the display shown in *Figure 23*.

- To change key assignments, press the + side of the **zoom**, **focus**, or **iris** keys.

Figure 23. PROGRAM SOFT KEYS display

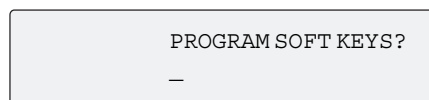

- At the *PRESS KEY TO PROGRAM* display (*Figure 24*), press any of the available reprogrammable keys. You can also program the *shifted* keys by holding the **esc** key and pressing the key. (See *Reprogrammable keys and commands* on page 67.)

Figure 24. PRESS KEY TO PROGRAM display



- At the command selection display, use the joystick (or the **||** and **▶** keys) to scroll up and down through the list of commands until you find the desired command. The commands are listed in alphabetical order. Then press the **↵** key (**◀** on the display) to save the selected command for the reprogrammed soft key.

Note: Pressing the **◀** key returns you to the *PRESS KEY TO PROGRAM* display.

- At the *PRESS KEY TO PROGRAM* display (*Figure 24*), press any of the available reprogrammable keys. (See *Reprogrammable keys and commands* on page 67.)

Figure 25. Command selection display

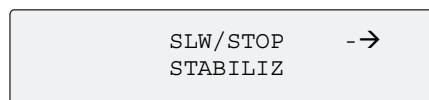

- At the *CONFIRM COMMAND SELECTON* display, press the + side of the **zoom**, **focus**, or **iris** key to confirm the assignment of the command for the key or press **◀** to return to the *PRESS KEY TO PROGRAM* display.

Figure 26. Confirm command selection display

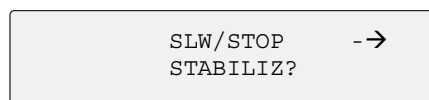

- The *KEY HAS BEEN PROGRAMMED* display flashes briefly, then the *PRESS KEY TO PROGRAM* display (*Figure 24*) returns. If you want to reprogram additional keys, repeat the process from step 4.

14. Press **esc** to exit to the *PROGRAM SOFT KEYS* display.

15. Pressing **▶** or the **-** side of the *zoom, focus,* or *iris* key takes you to the *CHANGE ACCESS CODES* display (Figure 27). If you press **+**, the menus in Figure 27 will appear in sequence. They allow you to change the codes used to access the user, remote, and supervisor menus.

The fourth display in the series allows you to set the access code for the keypad itself. The default value of zero means that operation is normal. (That is, no code is required.) Any other value means that you must enter that number followed by the Enter key in order to have access to the keypad.

Access will time out after a period of inactivity. The length of that period is set at the display in Figure 30 on page 27.

The series of four displays is activated only when you press **+** at the first display in Figure 27. You can navigate forward and backward within the displays themselves, but these displays will not appear when you navigate backward from the BAUD RATE display. Choosing **-** or **▶** from the CHANGE ACCESS CODES display.

16. Pressing **▶** or the **-** side of the *zoom, focus,* or *iris* key (in Figure 27) takes you to the *BAUD RATE* display (Figure 28). To change the baud rate used for RS-485 communication, enter the value here. Zero is the default value and selects the baud rate normally used for either standard systems or HDS systems using a system controller (see the following menu). Standard operation in either Digiplex or zone mode uses 9600 bps. The default value automatically switches to the proper rate for the type of system you will use the keypad in. If you choose another rate in the screen (9=9600, 19=19200, 38=38400), that rate is used whether in standard or System Controller mode. All other elements on the RS-485 bus must be set to the same rate.

Figure 27. CHANGE ACCESS CODES displays

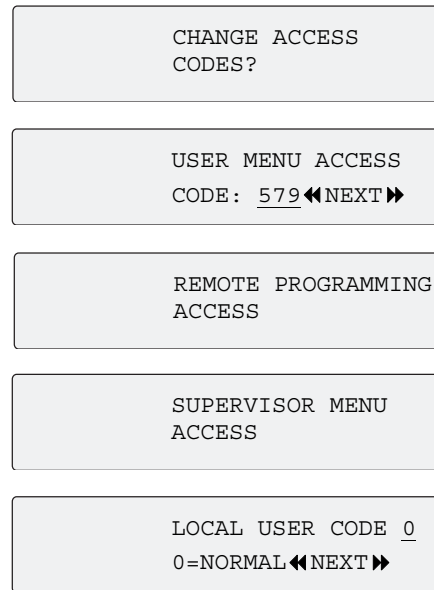
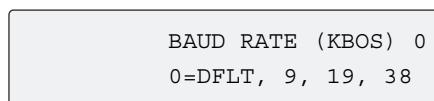
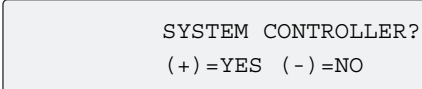

Figure 28. BAUD RATE display



17. Pressing **▶▶** or entering a baud rate value takes you to the *SYSTEM CONTROLLER* display (*Figure 29*). A System Controller is used with the HDS (High Density Switch) system to provide more comprehensive control of larger systems. In an HDS system, the keypad asks the System Controller for permission to access resources, including the keypad itself. To allow the keypad to access these resources, press the + key (YES) .

Figure 29. *SYSTEM CONTROL* display



```
SYSTEM CONTROLLER?  
(+) =YES  (-) =NO
```

18. If either System Controller mode (*Figure 29*) or local user code is active, the *INACTIVE TIMEOUT* display (*Figure 30*) will appear when navigating forward from the System Controller display. The value you enter here will determine the time in minutes that a login will persist with no activity from the user. If that time is exceeded, and there is no activity, you will be logged off and will have to log on again to continue operation. The default value is zero, which means you will never be logged off automatically.

Figure 30. *INACTIVE TIMEOUT* display

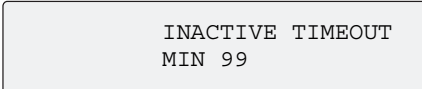

```
INACTIVE TIMEOUT  
MIN 99
```

19. Pressing **-** or **▶▶** takes you to the *OPERATING MODE* menu. (See *User programming* on page 28.) When you go into the User menu screens from the Supervisor menu, you can return to the Supervisor menu by backing up with the **◀◀** key.

User programming

As explained in *Entering programming modes* on page 21, to enter the user menus, from the *ENTER PROGRAMMING CODE* menu, press **5-7-9-seq**. This brings up the *OPERATING MODE* menu (*Figure 31*).

Figure 31. OPERATING MODE menu

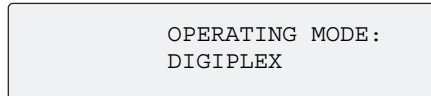

The operating mode defines the keypad’s system architecture. The choices are DIGIPLEX, which is conventional system operation (see *Standard Digiplex menus* on page 28), and ZONE, which divides the system into 32 zones (see *Zone menus* on page 31).

Standard Digiplex menus

The next five menus are used to set the system’s size to restrict the user from calling up unused addresses. They also define the maximum number of keystrokes used to automatically select an address. For example, if there are fewer than ten cameras in the system, the keypad user can select each camera site with only one key press.

1. Enter the highest camera number in your system.
2. Enter the highest monitor number in your system.
3. Enter the highest multiplexer number in your system.
4. Enter the highest VCR number in your system
5. Enter the highest preset number.

Figure 32. Maximum settings

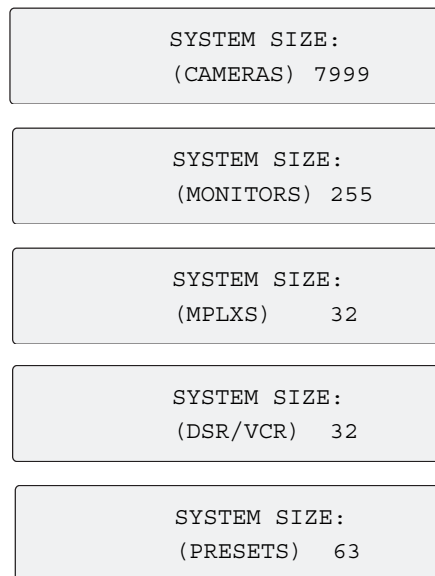

- The following access menus (*Figure 33*) are used to restrict the keypad from addressing specified sites in the system.

The access menus enable you to allow access for each camera, monitor, DSR/VCR, and multiplexer. To move from one type of access menu to another, press **▶** or **◀**.

Note: If you do not want to interrupt viewing at another keypad, program the keypad to address only the monitors within its view.

- Pressing **+** displays the following menu (*Figure 34*). The VCR output can be assigned an input number on the matrix switcher. When a VCR is called, the matrix switcher switches to the assigned input. Enter a number from 1 through 511, or enter 0 for NONE.

- These menus (*Figure 35*) are used to configure multiplexers.
- Use **||** or **▶** or the joystick to scroll through multiplexer manufacturers.
- If the DVMRe/multiplexer's outputs are connected to an input on a matrix switcher, enter the input number (1 to 511, or 0 for none).
- Enter the number of outputs (1 to 5) connected to the matrix switcher. This returns you to the *MPLX.xx ACCESS* menu.

Note: Outputs must be connected in sequential order to inputs if more than one output from a single DVMRe/mux is used.

Figure 33. Access menus

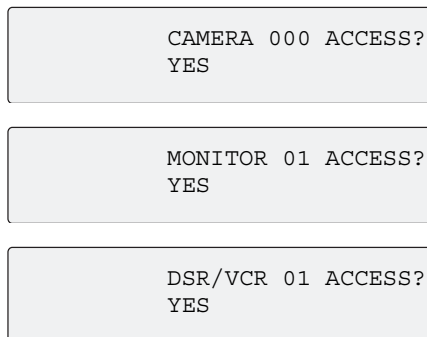

Figure 34. VCR access display

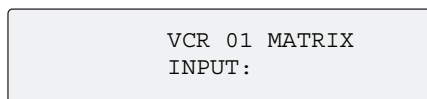
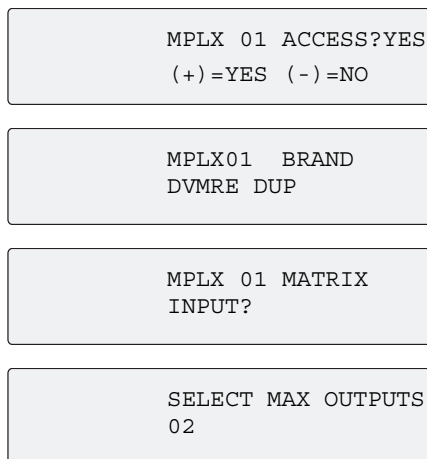

Figure 35. Multiplexer access display



- By default, the selected monitor number corresponds to the number of the matrix switcher output to which it is connected. For example, if monitor 12 appears in the keypad's display window and a camera selection is made, the monitor that is connected to output 12 of the matrix switcher switches to that camera.

In some applications, you might prefer to have the monitors numbered as 1, 2, 3, etc., instead of using the matrix switcher output number. To do this, subtract the desired monitor number from the matrix switcher output number and enter the difference as the monitor offset.

For example, suppose a keypad has a monitor that is connected to matrix switcher output 12. To enable the monitor to be addressed as monitor 1, subtract 1 from 12 and enter the difference (11) as the monitor offset.

In this example, if more than one monitor were to be controlled from the keypad, additional monitors would be connected to matrix switcher outputs 13, 14, 15, etc., and would be controlled as monitor 2, monitor 3, monitor 4, etc.

Note: The keypad will deny any monitor offset number that conflicts with the monitor system size and the monitor access programming choices that have been made.

- These menus are used to configure annunciation. When annunciation is enabled, the keypad displays the first, second, and third, call-in queue on the LCD and can store up to 32 call-in requests.
- Pressing + and then ► displays the following menu (*Figure 37*).
- In the annunciation mode, the keypad produces a tone on a call-in request or alarm. This sound can be set to one frequency (single) or to warble between two frequencies (multiple).

Figure 36. MONITOR OFFSET display

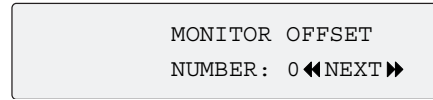
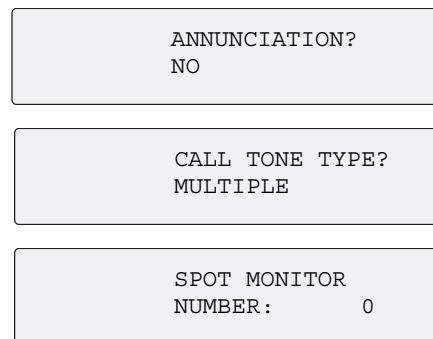

Figure 37. ANNUNCIATION displays



When a spot monitor number is assigned, pressing the **1st** key displays the first site number in the annunciation queue on the spot monitor, and the keypad automatically addresses control to that monitor.

Zone menus

Remember that the addressing between domes and multiplexers is offset. When setting up and controlling your cameras in zone mode, refer to *Receiver site addressing* on page 65).

To program your keypad in zone mode, do the following:

1. Bring up the *OPERATING MODE* menu (Figure 38).

Figure 38. *OPERATING MODE* menu

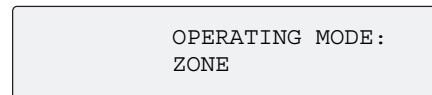

2. Select ZONE to displays the zone menu (Figure 39). This menu enables you to change the hub device label displayed on the LCD during normal operation. Label choices are ZONE, MPLX, DVMR, TERR, BLDG, FLR, DEPT, STA, SITE, or AREA. ZONE is the default label.

Figure 39. *Zone* menu

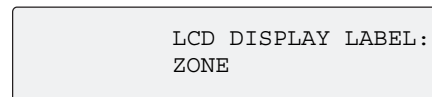

3. At the *ENTER ZONE ADDRESS* menu (Figure 40), pressing ► takes you to the *ZONE xx ACCESS* menu (Figure 47 on page 32).

Figure 40. *ENTER ZONE ADDRESS* menu

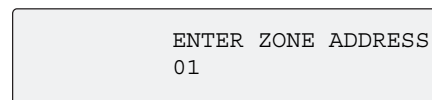

4. Enter a two-digit zone address to display the *ZONE xx TITLE* menu (Figure 41). Use the **||**, **▶**, **||▶**, or **◀||** keys or move the joystick to title the zone.

Figure 41. *ZONE xx TITLE* menu

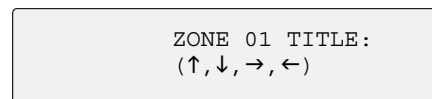

- ||** or **↑** Moves from a space to A through Z, to 9 through 0.
- ▶** or **↓** Moves from a space, to 0 through 9, to Z through A.
- ||▶** or **→** Moves the cursor right.
- ◀||** or **←** Moves the cursor left.

Zone titles enable you to identify which zone is being addressed (Building 248, Headquarters, etc.). A zone title can be up to 15 characters. Titles can include A through Z, 0 through 9, and spaces.

5. If you have reached the *ZONE TITLE* menu through the *SUPERVISOR* menu and enter or change the title, you have the option to send the title to all keypads in the system (Figure 42). This menu does not appear if you entered with the *USER* menu code.

Figure 42. *SEND TO ALL KEYPADS* display

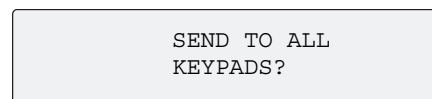

6. The next display mentions zone hubs (Figure 43). A hub is the main controlling device in a zone. Hub choices are DVMRE DUP, CALIBUR MMX, TRIPLEX MUX, DUPLEX MUX, SIMPLEX MUX, MATRIX SWCH, SYM DVR, and DVMRE TRI.
7. The next two menus are used to set the system's size to restrict the user from calling up unused addresses. They also define the maximum number of keystrokes used to automatically select an address. For example, if there are fewer than ten monitors in the system, the keypad user can select each monitor site with only one key press.

Note: Zone outputs and inputs depend on the hub you selected in the previous menu.

8. Enter the number of monitor outputs you have for this zone (1 to 32). Zone size choices are 4, 9, 10, 16, 32, and 64, depending on the hub (up to 64 for matrix switchers, up to 32 for multiplexers, up to 20 for SymDVR's, and up to 16 for all others).
9. The following system access menus (Figure 46) are used to restrict the keypad from addressing specified sites in the system.

Note: If you are using MMX or Triplex without a VCR attached through submacros, deny zone recorder access.

The last menu in Figure 46 returns you to the ENTER ZONE ADDRESS menu (Figure 40 on page 31).

10. From the ENTER ZONE ADDRESS menu (Figure 47), you can program all zones. When you have finished programming all zones, pressing ► from the ENTER ZONE ADDRESS menu displays the ZONE ACCESS menu (Figure 47).

- + or - Enables you to allow or deny access for each zone.
- Displays the next menu:.

Figure 43. Zone hub display

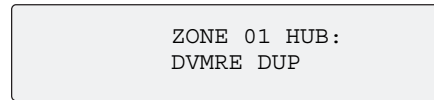

Figure 44. Zone monitor outputs

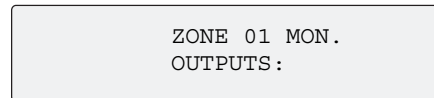

Figure 45. Zone camera inputs

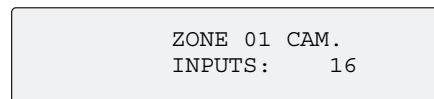

Figure 46. Access restriction menus

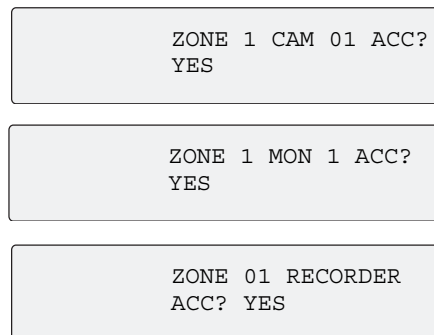
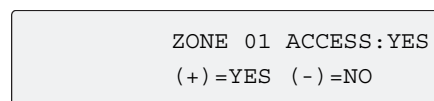

Figure 47. ZONE xx ACCESS menu



11. The annunciation menu (*Figure 48*) is for future use. When annunciation is enabled, the keypad displays the first, second, and third call-in/alarm on the LCD and stores up to 32 call-in requests.
12. Pressing + and then ► displays the call tone menu (*Figure 49*). In annunciation mode, the keypad produces a tone on a call-in request or alarm. This sound can be set to one frequency (single) or to warble between two frequencies (multiple).
13. When a spot monitor number is assigned (*Figure 50*), pressing the 1st key displays the first site number in the annunciation queue on the spot monitor, and the keypad automatically addresses control to that monitor.

Figure 48. Annunciation menu

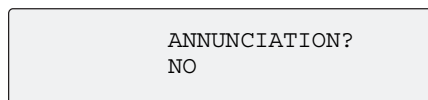

Figure 49. Call tone menu

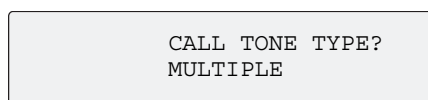
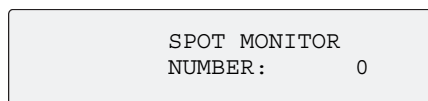

Figure 50. SPOT MONITOR NUMBER menu



Remote programming

At the *ENTER PROGRAMMING CODE* menu, press **9-5-1-seq** to display the *REMOTE PROGRAMMING menu*, which allows you to program devices such as cameras and VCRs, as shown in the tree in *Figure 51*.

Figure 51. Remote programming menu tree

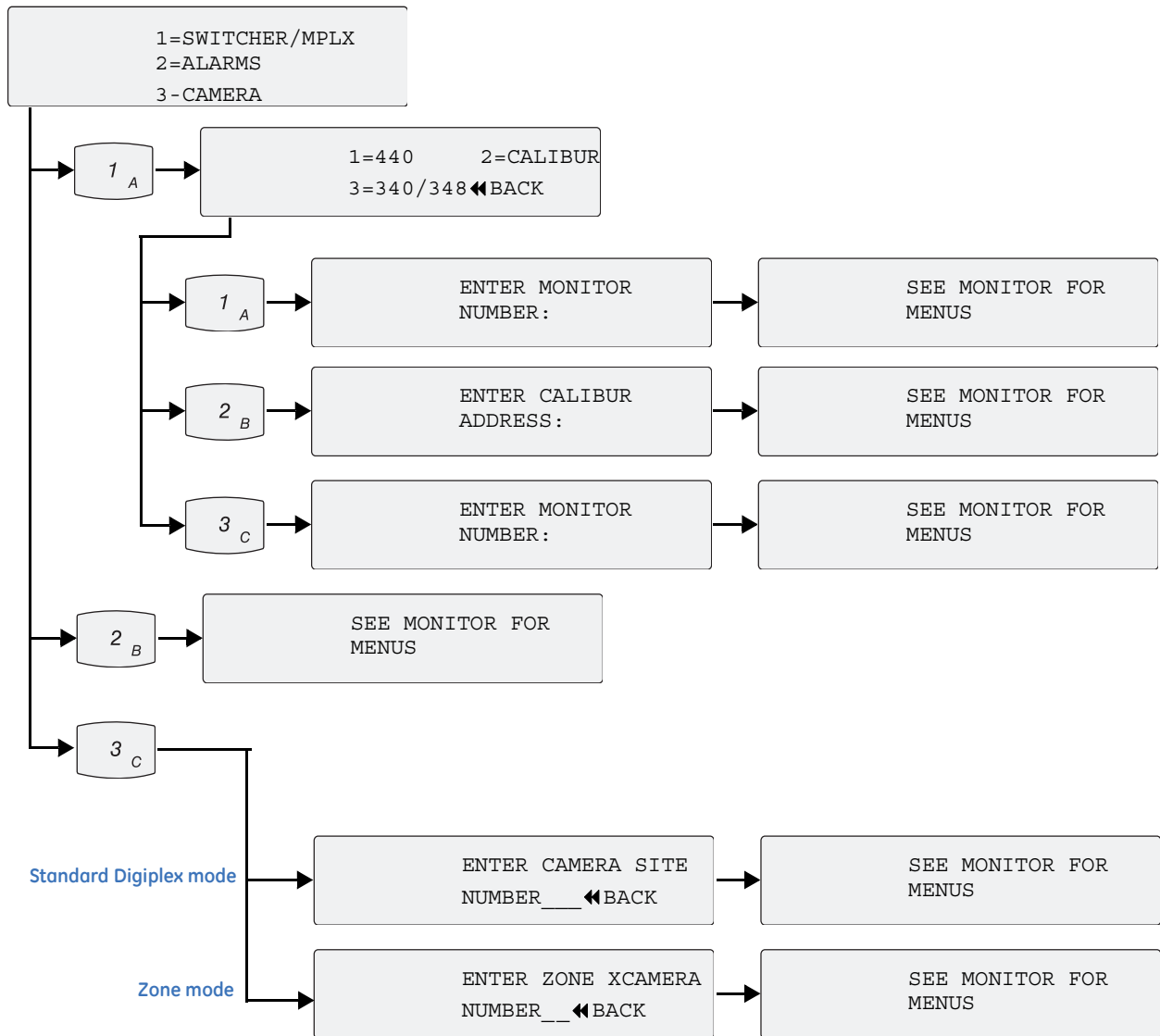

A few things to note about your choices within this menu tree:

- You must select the zone before entering programming mode.
- Pressing 3 in *standard Digiplex mode* prompts you to enter a camera site number.
- Pressing 3 in *zone mode* prompts you to enter a camera number in the current zone:

Note: Supervisors may disable remote programming.

Quick Shadow Tour 1 programming short cut

This section explains how to use the shadow tour 1 programming shortcut.

To program a ShadowTour™, do the following:

1. Beginning at the normal operating display, bring up the *PROGRAM SHADOW TOUR* display (Figure 52) by pressing and holding the **esc** key, then pressing the **tour** key.
2. At the *PROGRAM SHADOW TOUR* display (Figure 53), press the + side of the zoom, focus, or iris key to start recording a shadow tour.
3. Quickly move to the next step after the keypad beeps and the *END SHADOW TOUR PROGRAMMING* display appears (Figure 54).
4. Begin the manual operation sequence you want to record as your ShadowTour.
5. At the *END SHADOW TOUR PROGRAMMING* display, press the **esc** key to stop recording the shadow tour.

Note: The keypad is still recording your manual operation even though the *END SHADOW TOUR PROGRAMMING* display returns to the normal operating display after a few seconds. Continue your sequence and press **esc** to stop recording

Your shadow tour is now available for use. Follow the keypad's instructions for activating the shadow tour. See *Table 3* on page 38.

Note: The zoom, focus, and iris buttons do not work while programming a shadow tour using the short cut method. 405-2D users should not use this feature because the Zoom keys are disabled.

Figure 52. Normal operating display

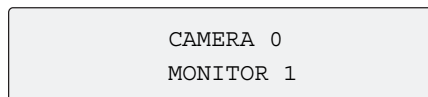

Figure 53. PROGRAM SHADOW TOUR display

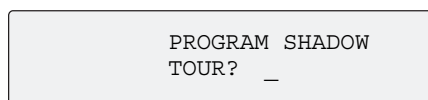

Figure 54. END SHADOW TOUR PROGRAMMING display



Chapter 4 Operation

This chapter explains how to operate your keypad. It also describes the different operating modes, standard Digiplex mode and zone mode.

In this chapter:

- Operating your keypad* 38
- Standard Digiplex mode* 41
- Zone mode*..... 48

Operating your keypad

Table 3 shows the default functions for the keypad’s keys in normal and shifted mode (shaded cells). To select the shifted mode, press and hold **esc** and then press the key. Some keys can be changed to other functions.

[Reprogrammable keys and commands](#) on page 67 in Appendix A shows which keys can be reassigned. Use the help function (shifted **mon** key) to find the current function assigned to any key.

Table 3. Normal and shifted key functions

Key	Function
mon	With number keys, selects active monitor from matrix switcher or multiplexer.
	Help
view	Works in two ways, depending on the type of multiplexer or DVMRe you are addressing: for duplex DVMRes and most multiplexers, pressing view steps selected monitor through programmed multiscreen views. Triplex DVMRes and some brands of multiplexers, pressing view with number keys selects multiscreen views (view, 2 calls up 2 x 2 view, and view, 4 calls up 4 x 4 view) If view is pressed and held for 5 seconds, the keypad will broadcast a command to all PTZ’s to display their site address and zone mode; Caliber devices will display their address; status disappears when the key is released.
	View message. Recalls the last message sent from HDS system controller.
zone	With number keys, selects a zone.
	Group. Activates group switching and group sequence initiation.
aux 1	Open gate (or other device) at selected camera address. *
	Unlock *
aux 2	Close *
	Lock *
aux 3	Stop *
	Flip. Pan 180 degrees to point in opposite direction.
aux 4	Last. Switches back to the camera selected just before the current one. For KTD-405A this is a talk function.
	Stabilize. Turns on the image stabilization function of the camera if preset.
seq	Activates a sequence tour on the active monitor.
	Function
alarm	Toggles active monitor between the alarm on and alarm off modes; calls up help menus when remotely programming matrix switcher and CyberDome.
	Lens reset. Sends a command to the camera module to reset the lens controller.
tour	With number keys 1 – 64, places PTZ camera in tour mode; or, if pressed and held for 3 sec, keypad beeps and sends an autopan command to PTZ camera. With number keys 1-16 Tours, unit limited. (IE CyberDome 2 supports 8, 4 Shadow Tours, 4 Preset Tours)
	Shadow. Starts programming Showdow Tour 1.

Table 3. Normal and shifted key functions (continued)

Key	Function
store	With number keys, sets presets and autopan limits for selected camera; accesses sequence programming for Calibur multiplexers.
	Group. Activates group switching and group sequence initiation.
find	With number keys, selects PTZ position saved by the previous store command for selected camera site.
	Step
+zoom -	Controls the zoom function on selected receiver site's motorized zoom lens.
	PTZ lockout on/off. Asserts or releases PTZ lockout priority. Lower priority keypads will lose PTZ control.
+focus -	Controls the focus function on selected receiver site's motorized zoom lens; disables the autofocus feature on CyberDome.
	Focus + = GRAB VID, Focus - = GRAB END
+iris -	Controls the iris function on selected receiver site's motorized zoom lens.
	Backlight bright/dim
esc	With number keys, clears alarms and clears number entry.
	No shifted function.
1st	Selects earliest of pending annunciations.
	Macro
autofocus	Places selected CyberDome camera in autofocus mode.
	Autopan
0 - 9	Selects camera (selects any numeric entry following other keys).
	No shifted function.
▶▶	Places selected DSR, DVMRe, or VCR in fast forward mode.
	Site up. Selects the camera number one more than the current one.
◀◀	Places selected monitor's DSR, VCR, or DVMRe in fast reverse mode.
	Site down. Selects the camera number one less than the current one.
▶▶▶	Advances selected DSR or DVMRe one frame forward in pause mode.
	Joystick right
◀◀◀	Steps selected DVMRe one frame backward in pause mode; selects reverse play in play mode.
	Joystick left
▶	Places selected DSR, VCR, or DVMRe in play mode.
	Joystick down
◀◀	Places selected DSR, VCR, or DVMRe in pause mode.
	Joystick up

Table 3. Normal and shifted key functions (continued)

Key	Function
■	Places selected monitor's DSR, VCR, or DVMRe in stop mode; esc plus ■ exits play mode in multiplexers.
	Live. Key for DVMRe live mode selection.
●	Places selected DSR, VCR, or DVMRe in record mode.
	Home. Sends current camera to preset 0.
	Toggles selected multiplexer's full-screen picture between normal and 2X magnification.
	Light, For PTZs that support WDR, This will toggle the WDR feature On and Off.
	Locates video on selected DVMRe.
	0 lux, Forces Day/Night switch, removes/adds IR cut filter.
(dsr/vcr)	With number keys, addresses remote recording device.
	Alt. Key for DVMRe.
face **	Control of specialized ID checking unit.
	Card *
badge **	Control of specialized ID checking unit.
	Door 1 *
over **	Control of specialized ID checking unit.
	Door 2 *
vol ▲ **	Increase audio volume. *
	Slow *
vol ▼ **	Decrease audio volume. *
	Fast *

* The action commands control specialized actions for auxiliary controllers at the site address of the current camera.

** These keys are present only on the KTD-405A.

Standard Digiplex mode

When you provide power to the unit, the normal operating display appears (*Figure 55*), showing the current camera number and the current monitor number.

Figure 55. Normal operating display

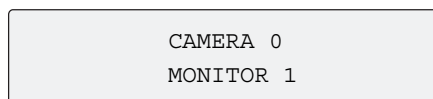

Selecting a monitor

There are two ways to enter the number for a new monitor:

1. Press the **mon** key.
2. Enter one of the following:
 - the monitor number including any preceding zeros; or
 - the monitor number directly.
3. Press **↵**.

The keypad remembers the last camera that was selected on the previous monitor. If a new monitor is selected that is the same as the one in use immediately before the current monitor, that last camera will be selected as well when the monitor is switched back. This allows you to alternate between two monitors and have the camera control follow the monitor selection. This only works for two monitors. If the monitor selected is not the previous one, the camera selection remains the same as it is on the current monitor.

Note: System controller mode will usually restore the last camera used with a monitor when that monitor is selected whether it was the last monitor or not.

Selecting a camera

When you select a camera, the keypad sends a command to the switching device to call that camera to the active monitor. There are two camera-selection methods:

- Enter the camera number including preceding zeros (for example, if you have tens of cameras, enter 01 for camera 1; if you have hundreds of cameras, enter 001 for camera 1).
- Enter the camera number directly (omitting preceding zeros), and then press **↵**.

Controlling a camera

PTZ. Pan, tilt, and zoom are controlled by the joystick. Zoom is also controlled by the + **zoom** - key.

To pan, move the joystick left or right. To tilt, move the joystick up or down. To zoom, twist the joystick knob clockwise or counterclockwise.

Focus. For autofocus, press the **autofocus** key. To focus manually, use the + **focus** - key.

Iris. The iris is controlled by the + **iris** -key; + opens the iris and - closes the iris.

Setting a preset

The KTD-405 has a number of features that allow users to quickly set camera presets directly from the keypad. Installers and supervisors can also manage this capability in a flexible way.

Setting presets from the keypad

PTZ cameras from GE Security have the ability to remember position settings and return to them on command. These position records are called presets. Users can instruct the camera to go to a stored position, that is, *find* or *recall* any preset that has been set up, by entering keystrokes on the keypad.

Note: Each GE PTZ has its own limitations for Presets, but the 405 keypad supports 1-127 plus Calling Home which is preset 0 for CyberDome 2. Also please see each PTZs user manual for more details.

If the system has been set to allow it, the user can also set the position of some presets directly from the keypad. Installers or supervisors have a flexible tool built into the keypad to manage this capacity.

When the keypad comes from the factory, the default settings allow the user to set presets 58 through 61 directly from the keypad. In addition the user can set the autopan limits which are stored in presets 62 and 63. Other GE PTZs can support additional presets 64-127, see their user manuals for more info. By default these also can be set from the keypad. With this default setting, presets below 58 must be set from the camera setup menus, which the user may or may not have access to.

The installer or supervisor can allow a user to set more or fewer presets from the keypad with a setting in the Supervisor menu. This setting is called the Lowest User Programmed Preset value (Preset Limit for short). It is set by factory default to 58. This is why, by default, the user cannot access presets below 58. If the supervisor sets this value to a lower number, all the preset numbers higher than or equal to that number will be accessible to be set directly from the keypad. Conversely, if it is set to a number higher than 63, the user cannot directly set presets in a Legend camera with numbers lower than that value (see [Shortcuts](#) for an exception to this statement).

To store a preset, do the following:

1. Position the camera.
2. Press **store**.
3. Enter the preset number using the number keys, or **aux 1, 2, 3**, or **4** for presets 58 through 61.

Note: Presets 62 and 63 cannot be set using the number keys; they can only be set by using the ◀ and ▶ keys.

4. Press **store**.

You must press the **store** key at the end as protection against inadvertently overwriting a previously stored position. For example, if the user intended to press the **find** key, the extra step would be unexpected, and the

user would realize the error. The keypad will prompt for the final **store** press, and give a confirmation message that it was actually stored. If the preset number is not in the allowed range, the keypad will give an error message instead of asking for the final press of the **store** key.

Shortcuts

There are two types of shortcuts provided by the keypad for setting and recalling presets. They are useful for preset that may be changed or recalled frequently. Presets 58 through 61 are accessible using the **aux** keys (**aux 1** to **aux 4**) instead of typing the number. Preset 58 is associated with **aux 1**, preset 59 with **aux 2**, and so on. To recall preset 60, for example, press **find** and then **aux 3**. To store preset 60 the press **store**, **aux 3**, and then **store** again. Except in one case, these preset shortcuts are always available, even if the Preset Limit is set to a value above the associated preset number. If the supervisor has set the Preset Limit to the value of 128, no presets at all can be set from the keypad, even the ones that govern the autopan limits.

There is one other, even quicker shortcut. The value of the Preset Limit setting itself defines a shortcut preset that can be accessed with only the **store** or **find** keys. For example, if the Preset Limit is set to 35, to store a position in preset 35, press the **store** key three times. In effect, the second press substitutes for typing the preset number. The preset defined by the Preset Limit can be recalled by pressing the **find** key twice. If the Preset Limit is set to a value above the maximum number of presets (set in the user menu) this shortcut is not available.

Recalling a preset

To recall a preset, do the following:

1. Press **find**.
2. Enter the preset number using the number keys, or aux, 1, 2, 3, or 4 for presets 58 through 61.

Operating group switching on Digiplex IV switchers

To operate a group, do the following:

1. In Digiplex mode, hold **esc** and press **zone** to display the *ENTER MONITOR GROUP* menu (Figure 56).
2. Enter a number from 1 through 64 that calls up that group of cameras, or press **tour** to display the *ENTER GROUP SEQUENCE* menu (Figure 57).
3. Enter a number from 1 through 12 initiates that group sequence.

Figure 56. Enter monitor group menu

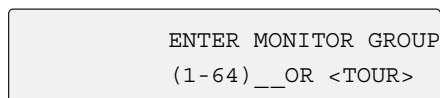

```
ENTER MONITOR GROUP
(1-64) __OR <TOUR>
```

Figure 57. Enter group sequence menu

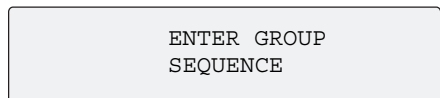

```
ENTER GROUP
SEQUENCE
```

Setting autopan limits

You can set the left and right autopan limits separately.

Left autopan limit

To set the limit for the left turn-around point of the camera's back and forth motion, as well as the tilt and zoom positions for the autopan, do the following:

1. Position the camera at the desired left limit.
2. Tilt and zoom the camera into the desired position.
3. Press **store**.

Note: Do not attempt to enter a preset number. The preset number 62 is reserved for the left autopan limit and is automatically entered when you perform step 5.

4. Press **◀**.
5. Press **store** again. The Store Preset Number displays on the keypad.

Right autopan limit

To set the limit for the right turn-around point of the camera's back and forth motion, do the following:

1. Position the camera at the desired right limit and press **store**.

Note: Do not attempt to enter a preset number. The preset number 63 is reserved for the right autopan limit and is automatically entered when you perform step 3.

2. Press **▶**.
3. Press **store** again. The Store Preset Number displays on the keypad.

Controlling a DVMRe/multiplexer (hybrid mode)



When you press the zone key, the keypad switches to the hybrid zone mode. In this mode, the keypad can control a DVMRe/multiplexer. Key functions are the same as those used during normal zone mode operation, except the **esc** key, which returns the keypad to the standard Digiplex mode. See *Table 4*. The keypad can control DVMRe recorders with addresses up to 250. All units with addresses above 32 must have the same characteristics and permissions as unit 32.

Note: Camera control (PTZ) is disabled while in the hybrid zone mode.

Controlling a recording device

When a recording device is selected, it can be controlled by the keypad. (See *Table 4, Controlling a recording device* and *Receiver site addressing* on page 65 for details.)

Table 4. Controlling a recording device

Control	Function for DSR/VCR	Function for DVMRe and SymDecs
●	starts record mode	starts record mode
▶	starts playback mode	starts playback mode
■	stops record or playback mode	stops record or playback mode
	pauses playback	pauses playback or live view
▶▶	fast forwards playback	fast forwards playback
◀◀	rewinds playback	rewinds playback
▶	forwards playback by frame (action depends on DSR/VCR)	in reverse: shifts play direction to forward in pause mode: steps playback forward one frame
◀	reverse playback (action depends on DSR/VCR)	playing forward: shifts play direction to reverse in pause mode: steps playback in reverse one frame
		zooms image to 2X magnification (toggle) Note: Not supported by SymDecs.
		calls up screen to search for specific recording puts DVMRe in playback mode
Joystick	twisting right: steps forward at a variable rate twisting left: steps in reverse at a variable rate	in play or pause mode right: fast forwards left: rewinds up: skips forward approximately 15 sec down: skips backward approximately 15 sec twisting right: steps forward at a variable rate twisting left: steps in reverse at a variable rate return to center: resumes pause mode with 2X magnification on right: pans right left: pans left up: pans up down: pans down

System information menus

In standard Digiplex mode, holding **mon** at the normal operating menu displays three system information menus. These menus show the keypad’s address, version, and system size setting. Use **◀** and **▶** to navigate through these menus. To exit the system information menus, press **◀** from the first menu or press **esc**.

Figure 58. Maximum values

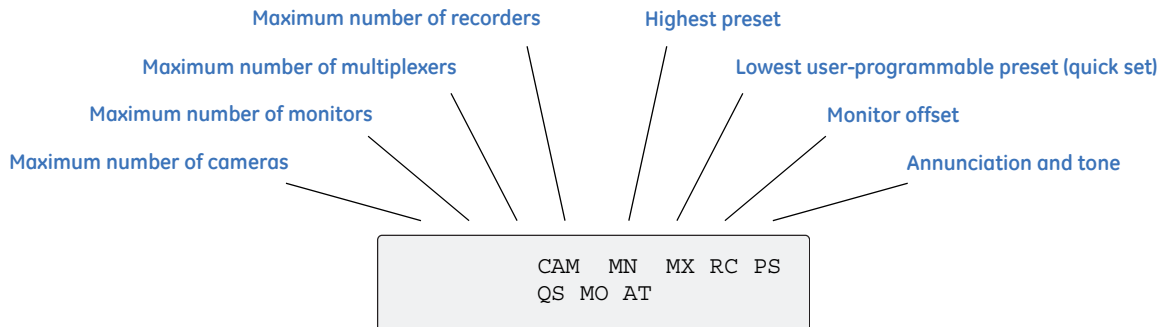

Numbers shown are for system controllers; for Digiplexes, the camera maximum is 1023 and the monitor maximum is 128.

Help menu

The HELP menu lets you determine the function associated with each key.

To display the HELP menu (Figure 59), at the normal operating display, press and hold the **esc** key, then press the **mon** key. Release both keys.

Figure 59. HELP menu

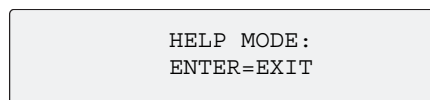

To display a key’s default function, at the HELP menu, press the key. To display a key’s shifted (secondary) function, press **esc** and the key. (See Table 3 on page 38 for a list of keys and their default assignments for normal and shifted functions.)

The help menu times out in ten seconds. To force an exit, press **↵**.

Audio

Annunciation and alarms

When a keypad is programmed for site annunciation, it stacks as many as 32 call-in requests in the order in which they are received. The numbers of the first three sites appear in the keypad's display window (*Figure 60*).

Figure 60. Normal operating display with annunciation

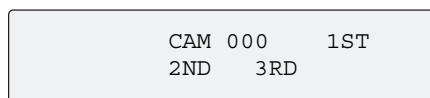

To call up the first site:

Press the **1st** key. The site will be removed from the queue and the waiting requests will move up in order.

To call up any site in the queue:

Press **0** through **9** to enter a site number. The site will be removed from the queue and the waiting requests will move up on order.

Note: When an annunciation call is received, a tone sounds every 15 seconds until the call is cleared by an operator. In multiplexer mode, the tone sounds every 5 seconds.

Two-way audio

To establish two-way audio communication with a site:

1. Press **0** through **9** to enter a site number.
2. Use the **vol** (volume) keys to adjust the audio level.
3. Press **aux 4** to talk to the site. The **aux 4** key on the audio-version of the keypad automatically defaults to the talk function.

Zone mode

The LCD displays the zone number and title on the top line and the current camera and monitor numbers on the bottom line (*Figure 61*).

Figure 61. Zone mode main menu

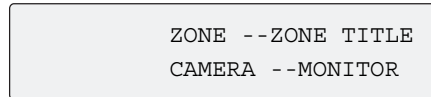

To select a zone, press **zone** and enter the zone number.

The LCD displays the zone number and title, which is created during programming.

Selecting a camera

Use one of the following methods to enter the camera number to select a new camera.

- Enter the camera number including any preceding zeros. (For example, if you have tens of cameras, enter 01 for camera 1; if you have hundreds of cameras, enter 001 for camera 1.)
- Enter the camera number directly (omitting preceding zeros), then press **↵**.

Controlling a camera

The control address of a PTZ camera in zone mode is offset from the number used to select it. When setting up and controlling your cameras in zone mode, refer to [Receiver site addressing](#) on page 65 in Appendix A.

PTZ. Pan, tilt, and zoom are controlled by the joystick. Zoom is also controlled by the + **zoom** - key.

To pan, move the joystick left or right. To tilt, move the joystick up or down. To zoom, twist the joystick knob clockwise or counterclockwise.

Focus. For autofocus, press the **autofocus** key. To focus manually, use the + **focus** - key.

Iris. The iris is controlled by the + **iris** - key; + opens the iris, - closes the iris.

Note: Refer to the CyberDome manual for additional operation on some CyberDome models.



Selecting a monitor

1. Press the **mon** key.
2. Enter the monitor number including any preceding zeros or enter the monitor number directly and press **enter**.

Selecting and controlling a DVMRe/multiplexer

When a zone is active, the corresponding DVMRe/multiplexer can be controlled by the keypad (*Table 5*).

Table 5. Controlling a multiplexer

Control	Function for multiplexer	Function for DVMRe
●	starts record mode	starts record mode
▶	starts playback mode (if multiplexer has an attached DSR/VCR, a play command is sent to the multiplexer and the VCR)	starts playback mode
■	stops playback or record mode	stops playback or record mode
	pauses live picture; pauses playback	pauses playback or live view
	toggles image between normal and 2X magnification (joystick moves view)	zooms image to 2X magnification (toggle)
		calls up screen to search for specific recording puts DVMRe in playback mode
Joystick	<p>when attached to a DSR/VCR in pause mode twisting right: steps forward at a variable rate twisting left: steps in reverse at a variable rate</p> <p>in any mode with 2X magnification right: pans right left: pans left up: pans up down: pans down</p>	<p>in play or pause mode right: fast forwards left: rewinds up: skips forward approximately 15 sec down: skips backward approximately 15 sec twisting right: steps forward at a variable rate twisting left: steps in reverse at a variable rate return to center: resumes pause mode</p> <p>with 2X magnification on right: pans right left: pans left up: pans up down: pans down</p>
▶▶	fast forwards playback	fast forwards playback
◀◀	rewinds playback	rewinds playback
▶	in pause mode, steps forward one frame	<p>in reverse: shifts play direction to forward in pause mode: steps playback forward one frame</p>
◀	in pause mode, steps in reverse one frame	<p>playing forward: shifts play direction to reverse in pause mode: steps playback in reverse one frame</p>

To enter a Calibur DVMRe/multiplexer’s programming menus, do the following:

1. Enter the remote programming mode:
 - a. Press and hold **↵**.
 - b. Press **9-5-1-seq.**
2. Select **1**, switcher/multiplexer.
3. Select **2**, Calibur.
4. Enter the Calibur address.
5. Press **↵**.
6. Enter the Calibur password.

To navigate the DVMRe/multiplexer programming menus, see *Table 6*.

Table 6. Navigating Calibur menu

Control	Function
Joystick	moves left and right within menu options; can be used to move up and down within the menu options
▶▶	makes selections
◀◀	backspaces out of selections; exits the programming menus if pressed in the main menu
	moves up within menu options
▶	moves down within menu options
▶	moves right within menu options
◀	moves left within menu options
↵	interchangeable with ▶▶
esc	interchangeable with ◀◀

Programming a DVMRe/multiplexer camera sequence

If you are using a Calibur DVMRe/multiplexer, set a camera sequence by doing the following:

1. Press **store**.
2. Press **seq.** to display the *ENTER SEQUENCE* menu (*Figure 62*).
3. Enter the number of the first camera in the sequence.
4. Wait the amount of time you want between cameras, then press the next camera in the sequence.
5. Repeat step 4 until all cameras in the sequence have been entered.
6. Press **▶▶**.

Figure 62. Enter sequence menu

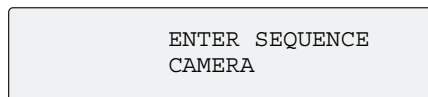

Note: Pressing **seq** toggles between sequencing and not sequencing.

Chapter 5 Troubleshooting and support

This section provides information to help you diagnose and solve various problems that may arise while configuring or using your GE Security product and offers technical support contacts in case you need assistance.

In this chapter:

- Troubleshooting your keypad* 54
- Contacting us* 56

Troubleshooting your keypad

This section provides information to help you diagnose and solve various problems that may arise while configuring or using your GE Security product and offers technical support contacts in case you need assistance. (See [Contacting us](#) on page 56.)

Adhere to all installation guidelines while making connections, including those provided in section *Chapter 2, Installation* on page 7.

- *I can't control the cameras or DMVRes.*

This could be the result of a number of different causes. First, make sure that you are in zone mode while trying to control cameras through a DVMRe. Also try cycling the power on the DVMRe and keypad to see if a simple reset will correct the problem.

If that doesn't solve the problem, check the wiring, verifying the following:

- The correct type of wiring (STP or UTP) is being used for the different signals.
- All wires are in good condition.
- All cabling and pinout connections are made according to directions (observing polarity).
- Equipment is properly terminated.
- Cables are properly grounded.

Lastly, the cause of the problem could be incorrect wiring of dome inputs or incorrect zone addressing (camera addressing starts at 0 in zone mode). The address of the camera has to be one less than the input on the DVMRe. Readdress the cameras or move the coaxial connections up one input on the DVMRe.

If none of these solutions corrects the problem, contact customer support.

- *I cannot connect to a DVMRe.*

Make sure that the correct hub device is selected in the zone programming menus. The selection defaults to Triplex. Also check the termination and bias settings (see [Installation guidelines](#) on page 8).

- *I have lost control between keypads that are connected using RS-422.*

The keypad may be positioned incorrectly on the RS-422 control line with a switcher and data merger.

Refer to the keypad, switcher, and data merger installation instructions and correct wiring along RS-422 control line. With the KTD-405 keypad, the units should be in line in the following order: keypad, data merger, and switcher.

- *Audio on KTD-405A keypads is unclear.*

You probably have incorrectly set jumpers or a faulty KTD-336. Ensure that the attenuation jumpers are set as described in [Two-way audio](#) on page 47.

If a KTD-336 is present, ensure that its relays are not clicking. If they are, contact customer support.

- *I cannot control the dome camera.*

You may have poor voltage or resistance on the data line. If the wiring, addressing, and termination of the camera and keypad are all correct, verify that the voltage along the RS-422 data line reads approximately 1.5 VDC and that it drops when a command is sent. If it isn't, check the power line. Also verify that the resistance across the RS-422 data line is between 95 and 125 ohms. If it isn't, contact customer support.

- *I cannot accurately program a shadow tour using RS-485 or ASCII protocols while using KTD-405-2D.*

While recording shadow tours, RS-422 and ASCII protocols cannot communicate nor record all camera commands while the pan/tilt joystick and zoom buttons are used simultaneously. Use zoom commands separately from pan/tilt commands during shadow tour programming.

Contacting us

For help installing, operating, maintaining, and troubleshooting this product, refer to this document and any other documentation provided. If you still have questions, contact us during business hours (Monday through Friday, excluding holidays, between 5 a.m. and 5 p.m. Pacific Time).

Table 7. Technical support

North America	Latin America
T: 888 GE Security (888.437.3287). Toll-free in the US, Puerto Rico, and Canada. 503.885.5700 outside the toll-free area. F: 888.329.0332 (Tualatin tech support) E: nstechsrv@ge.com (tech support) gesecurity.customerservice@ge.com (customer service)	T: 305.593.4301 F: 305.593.4300 E: InfraSec.TechnicalServicesLatinAmerica@ge.com (técnica) InfraSecCustomerService.LatinAmerica@ge.com (cliente)
	Europe, Middle East, and Africa
	W: At www.gesecurity.eu , select <i>Customer Support</i> .

Note: Be ready at the equipment before calling.

Online resources

Here are some useful links on our website www.gesecurity.com:

Online library. From the *Customer Support* menu, select the [Resource Library](#) link. After you register and log on, you may search through our online library for the documentation you need.¹

Training. To view any available online training for GE Security products, select the [Training](#) link. (Online training is not available for all products.)

Warranty and terms information. From the *Customer Support* menu, select [Return and Warranty Policy Statement](#) or [Terms and Conditions Policy Statement](#).

Customer service and technical support. From the *Customer Support* menu, select [Customer Service](#) or [Technical & Application](#). Select the appropriate product category for the contact information or use the dropdown menu to select a location outside the US.

1. Many GE documents are provided as PDFs (portable document format). To read these documents, you will need Adobe Reader, which can be downloaded free from Adobe's website at www.adobe.com.

Appendix A Sample configurations and charts

This appendix provides several sample configuration diagrams to help you visualize your system and also includes DIP switch aids, charts, and other helpful information.

In this appendix:

<i>Sample analog system configurations</i>	58
<i>Sample IP system configuration</i>	64
<i>Receiver site addressing</i>	65
<i>Reprogrammable keys and commands</i>	67
<i>System planning chart</i>	69

Sample analog system configurations

Figure 63. Typical KTD-405/KTD-405-2D Digiplex configuration

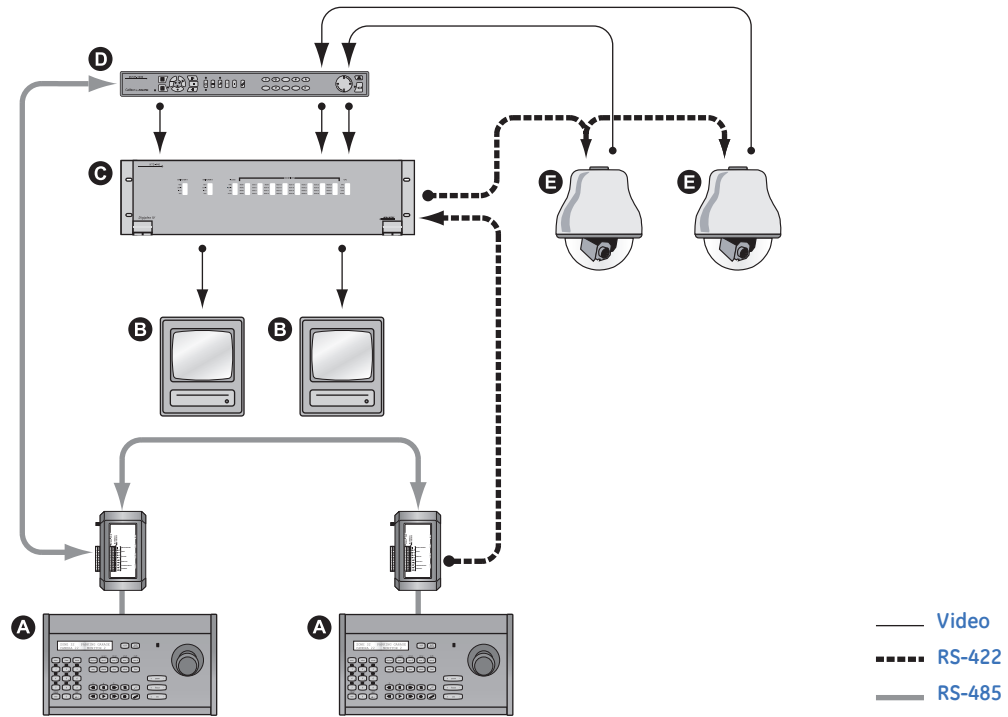

- A** Keypads (with I/O boxes)
- B** Monitors
- C** Matrix video switcher
- D** DVMRe
- E** CyberDomes

Figure 64. Typical KTD-450A Digiplex configuration

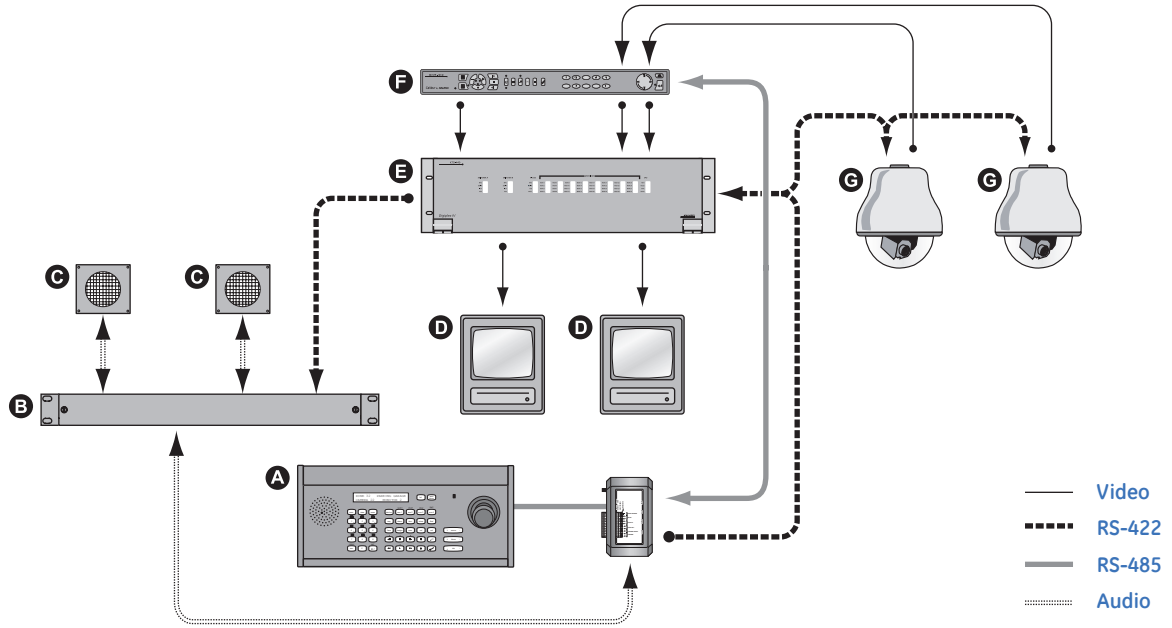

- | | | |
|----------------------------------|--------------------------------|---------------------|
| A KTD-405A (with I/O box) | D Monitors | F DVMRe |
| B Relay follow | E Matrix video switcher | G CyberDomes |
| C Audio | | |

Figure 65. Zone configuration

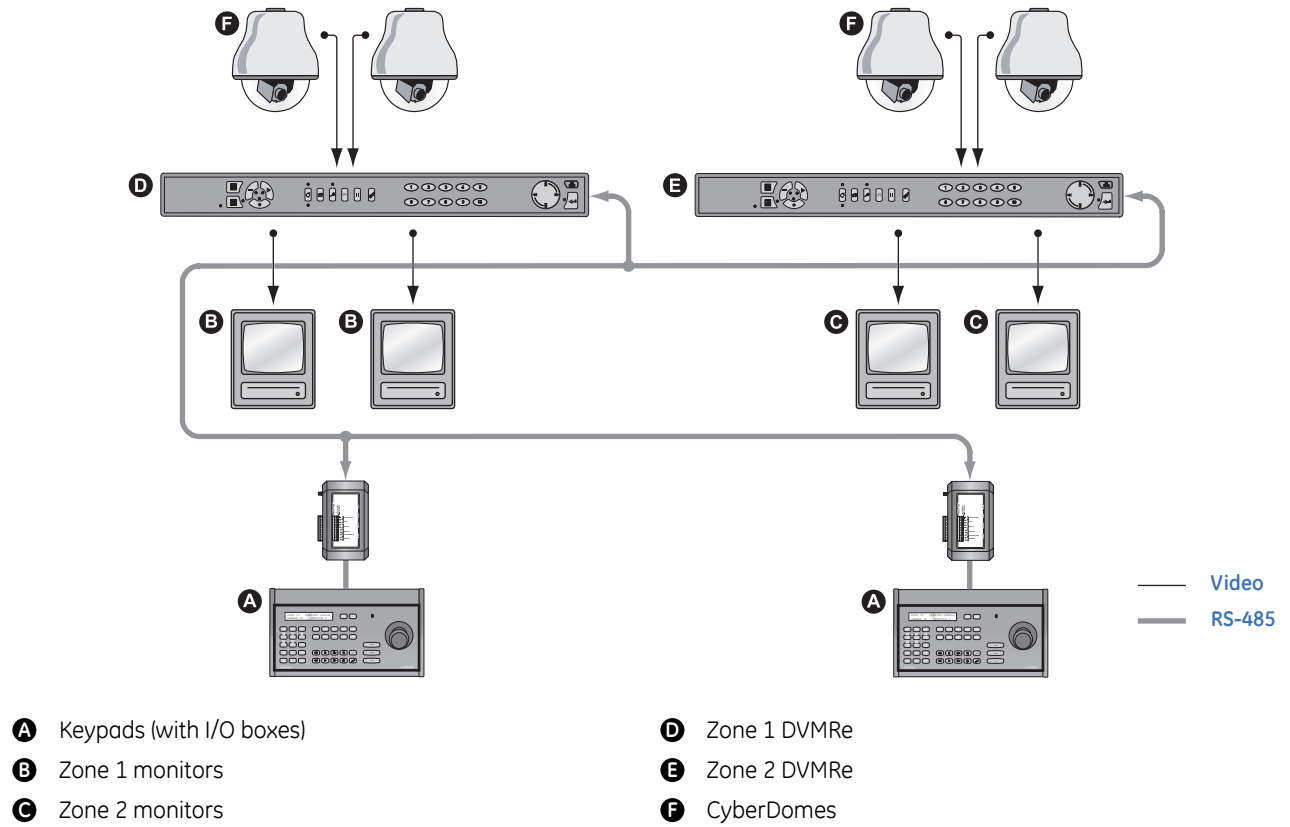

Old I/O box connections

Figure 66. Old I/O box connections for audio and nonaudio keypads

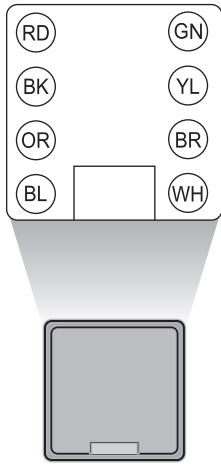

Nonaudio I/O box

- Ⓡⓓ RS-485 A
- ⓅⓀ RS-485 B
- ⓄⓇ 12 VDC in (no polarity)
- ⓅⓁ 12 VDC in (no polarity)
- ⓖⓃ RS-422 in B
- ⓎⓁ RS-422 in A
- ⓅⓇ RS-422 out B
- ⓌⓂ RS-422 out A

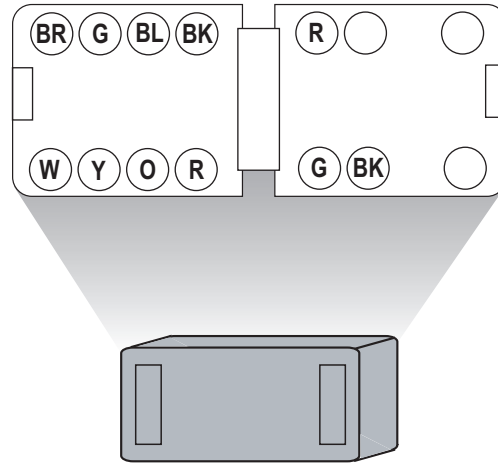

Audio I/O box

Data connections

- ⓅⓇ RS-422 out B
- Ⓦ RS-422 out A
- ⓖ RS-422 in B
- Ⓨ RS-422 in A
- ⓅⓁ 12 VDC in (no polarity)
- Ⓞ 12 VDC in (no polarity)
- ⓅⓀ RS-485 B
- Ⓡ RS-485 A

Audio connections

- Ⓡ Audio A
- ⓖ Shield (float in field)
- ⓅⓀ Audio B

Figure 67. Connecting a multiplexer or DVMRe to the old I/O box

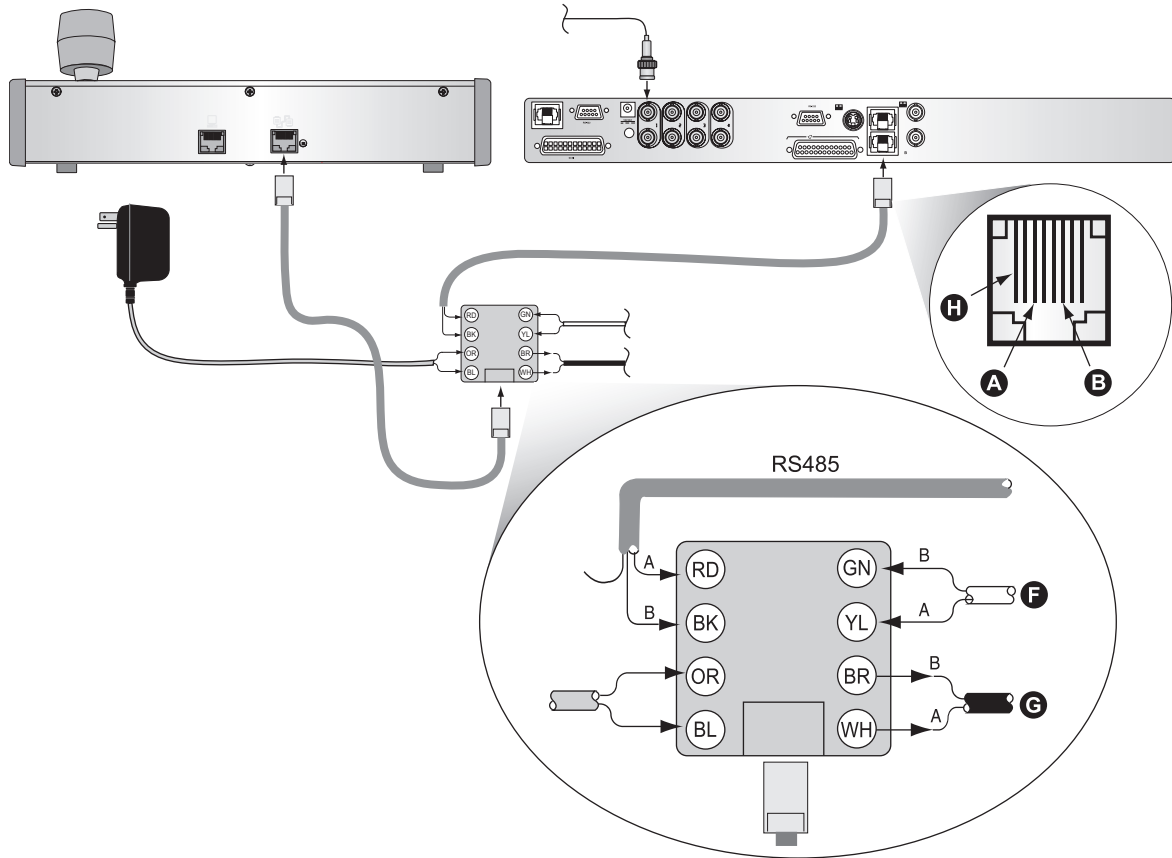

- A** Connect PIN 3 to RS-485 A (RD)
- B** Connect PIN 6 to RS-485 B (BK)
- C** Floating shield
- D** 12 VDC in (no polarity)
- E** To multiplexer or DVMRe (ground at mux/DVMRe)
- F** RS-422 input (if used)
- G** RS-422 output (to CyberDomes/PTZ receivers)
- H** Connect PIN 1 to RS-485 shield

Connecting multiple keypads to the old I/O box

Figure 68. Multiple KTD-405 connections

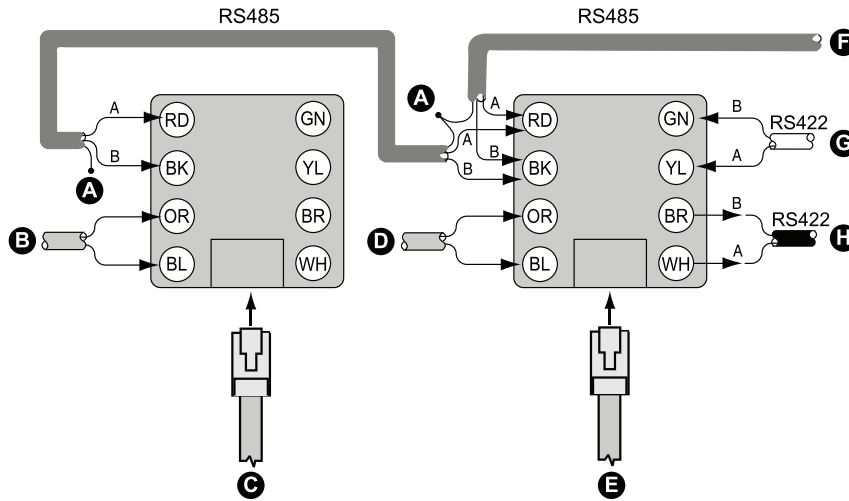

- A** Shield (float)
- B** 12 VDC in (no polarity)
- C** To/from KTD-405
- D** 12 VDC in (no polarity)
- E** To/from KTD-405
- F** To additional keypads or multiplexer/DVMRe (ground at mux/DVMRe)
- G** RS-422 input (if used)
- H** RS-422 output (to CyberDomes)

Figure 69. KTD-405/KTD-405-2D to KTD-405A connections

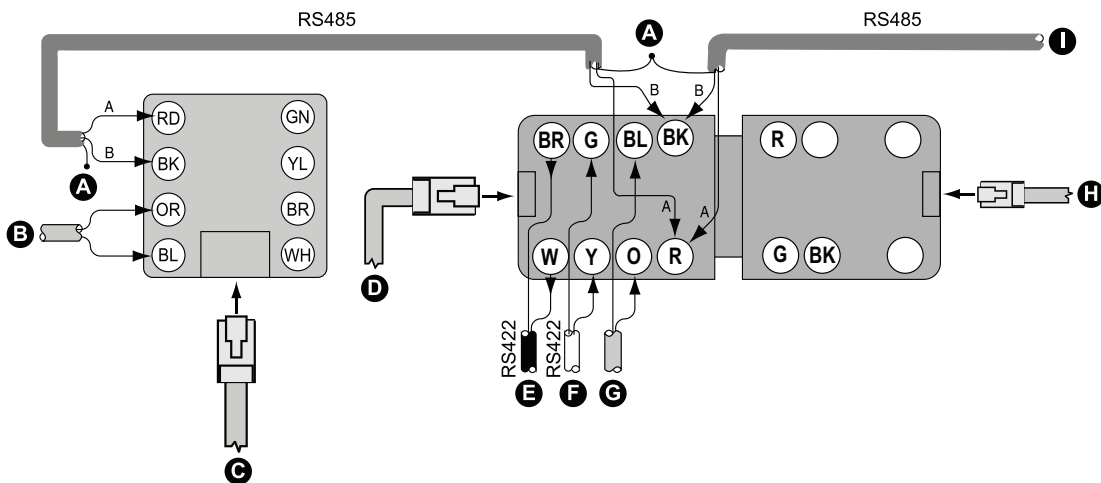

- A** Shield (float)
 - B** 12 VDC in (no polarity)
 - C** RJ45 to/from KTD-405
 - D** RJ45 to/from KTD-405A
 - E** RS-422 output (to CyberDomes)
 - F** RS-422 input (from alarm chassis)
 - G** 12 VDC in (no polarity)
 - H** RJ11 to/from KTD-405A
 - I** To additional keypads or multiplexer/DVMRe (ground at mux/DVMRe)
- Audio connections**
- R** Audio A
 - G** Float shield in field
 - BK** Audio B

Sample IP system configuration

In *Figure 70*, the four IP sources are GE Legend IP domes. The domes' ID addresses need to be programmed as #17, #18, #19, and #20 as the IP inputs. To control them you should have the PTZ units site address set to 16, 17, 18, and 19.

The SymDec 16 plus 4 is capable of recording 16 analog video signals and 4 IP streamed video signals. Any video source can be a PTZ (pan/tilt/zoom) device. Only a KTD-405 keypad or SymNav may be used to control a PTZ device. *Figure 70* is an example of a SymDec single-zone system configuration.

Note: All GE IP dome's addresses are always one number lower than the physical input number on the SymDec 16 plus 4.

Figure 70. SymDec 16 plus 4 single-zone system configuration

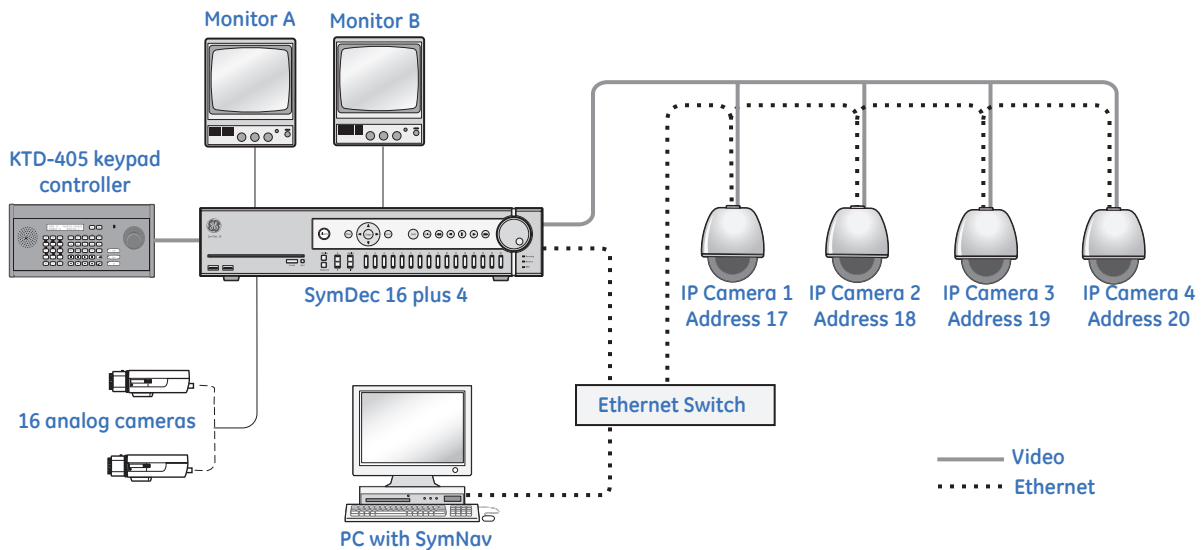

We have upgraded KTD-405 and SymDec 16 firmware to allow this new functionality. The latest KTD-405 firmware includes a new device type, SymDVR, now available in the hub list. Installers using zone mode can now select analog and IP cameras connected to the SymDec device in sequential order.

In the SymDec device firmware upgrade, the SymDec device now assigns the cameras attached to the IP ports as the next device ID following the last analog port. For a SymDec with 16 analog ports and 4 IP ports, the IP ports will address cameras 16, 17, 18, and 19 (zero base ID).

To upgrade your KTD-405, order part #1037271 from GE Security. The upgrade kit consists of two EPROMs with the updated firmware, version 1.4. To upgrade your SymDec device firmware, open a browser window, and navigate to <http://www.gesecurity.com/videoupgrades>. Click on the *Current Product Flash Upgrade Files* link. Click on the *SymDec16 plus 4* link, and then read the instructions on the page.

Receiver site addressing

Each receiver has a DIP switch used to assign its site address. To determine the receiver site address, see *Table 8*, *Table 9*, and *Figure 71* on page 65 and perform the following:

1. Determine which position values must be added together to equal the site number.
2. Place the switches that correspond to those values in the ON position

One way to determine which switches to use is to subtract the highest possible switch value from the address you want, then subtract the highest possible switch value from that difference. Continue to subtract the highest possible switch value from the difference until you have zero.

For example, assume you want address 209. The highest value under 209 is 128 (switch 8). Subtracting 128 from 209 yields 81. The highest value under this remainder is 64 (switch 7). Subtracting 64 from 81 yields 17, and from there you would subtract 16 (switch 5) and 1 (switch 1).

Therefore, for address 209, you would use switches 8, 7, 5, and 1 (equivalent to $128 + 64 + 16 + 1 = 209$). See *Figure 71*.

Figure 71. Receiver site address DIP switches (set to 209)

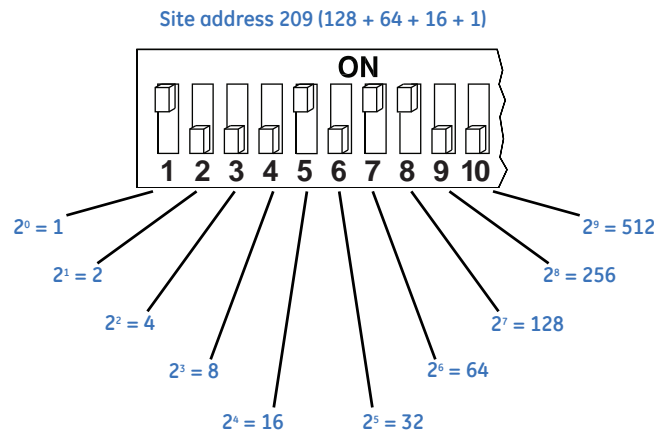

Table 8. Dip switch positions and equivalent values

DIP switch position number	1	2	3	4	5	6	7	8	9	10
Equivalent value	1	2	4	8	16	32	64	128	256	512

Table 9. Receiver site addressing values by zone

Camera input	Zone number															
	1	2	3	4	5	6	7	8	9	10	11	12	13	14	15	16
1	0	32	64	96	128	160	192	224	256	288	320	352	384	416	448	480
2	1	33	65	97	129	161	193	225	257	289	321	353	385	417	449	481
3	2	34	66	98	130	162	194	226	258	290	322	354	386	418	450	482
4	3	35	67	99	131	163	195	227	259	291	323	355	387	419	451	483
5	4	36	68	100	132	164	196	228	260	292	324	356	388	420	452	484
6	5	37	69	101	133	165	197	229	261	293	325	357	389	421	453	485
7	6	38	70	102	134	166	198	230	262	294	326	358	390	422	454	486
8	7	39	71	103	135	167	199	231	263	295	327	359	391	423	455	487
9	8	40	72	104	136	168	200	232	264	296	328	360	392	424	456	488
10	9	41	73	105	137	169	201	233	265	297	329	361	393	425	457	489
11	10	42	74	106	138	170	202	234	266	298	330	362	394	426	458	490
12	11	43	75	107	139	171	203	235	267	299	331	363	395	427	459	491
13	12	44	76	108	140	172	204	236	268	300	332	364	396	428	460	492
14	13	45	77	109	141	173	205	237	269	301	333	365	397	429	461	493
15	14	46	78	110	142	174	206	238	270	302	334	366	398	430	462	494
16	15	47	79	111	143	175	207	239	271	303	335	367	399	431	463	495
17	16	48	80	112	144	176	208	240	272	304	336	368	400	432	464	496
18	17	49	81	113	145	177	209	241	273	305	337	369	401	433	465	497
19	18	50	82	114	146	178	210	242	274	306	338	370	402	434	466	498
20	19	51	83	115	147	179	211	243	275	307	339	371	403	435	467	499
21	20	52	84	116	148	180	212	244	276	308	340	372	404	436	468	500
22	21	53	85	117	149	181	213	245	277	309	341	373	405	437	469	501
23	22	54	86	118	150	182	214	246	278	310	342	374	406	438	470	502
24	23	55	87	119	151	183	215	247	279	311	343	375	407	439	471	503
25	24	56	88	120	152	184	216	248	280	312	344	376	408	440	472	504
26	25	57	89	121	153	185	217	249	281	313	345	377	409	441	473	505
27	26	58	90	122	154	186	218	250	282	314	346	378	410	442	474	506
28	27	59	91	123	155	187	219	251	283	315	347	379	411	443	475	507
29	28	60	92	124	156	188	220	252	284	316	348	380	412	444	476	508
30	29	61	93	125	157	189	221	253	285	317	349	381	413	445	477	509
31	30	62	94	126	158	190	222	254	286	318	350	382	414	446	478	510
32	31	63	95	127	159	191	223	255	287	319	351	383	415	447	479	511

Reprogrammable keys and commands

From the supervisor programming mode you can reprogram any of the soft keys with any of the available commands.

Note: Holding the **seq** key for three seconds returns you to the normal operating display, except on displays where **esc** is required to exit.

To reprogram soft keys, do the following:

1. Beginning at the normal operating display, enter the supervisor programming mode by pressing and holding the **↵** key.
2. After the keypad beeps and the code entry display appears (*Figure 73*), quickly enter the access code for the supervisor menus by pressing the **1-4-7-6-*seq*** key sequence. The display will automatically advance to the next display.
3. Press the **▶▶** key (for NEXT) until the *PROGRAM SOFT KEYS* display appears (*Figure 74*). Press the + side of the *zoom*, *focus*, or *iris* key.

Note: Use the plus side of any of these keys for YES and the minus side of any of these keys for NO.

Figure 72. Normal operating display

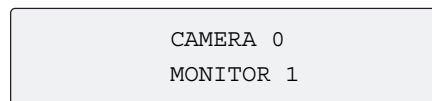

Figure 73. Code entry display

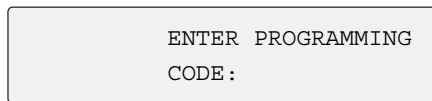

Figure 74. PROGRAM SOFT KEYS display

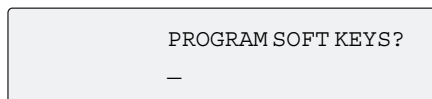

Figure 75. Keys that can be reprogrammed

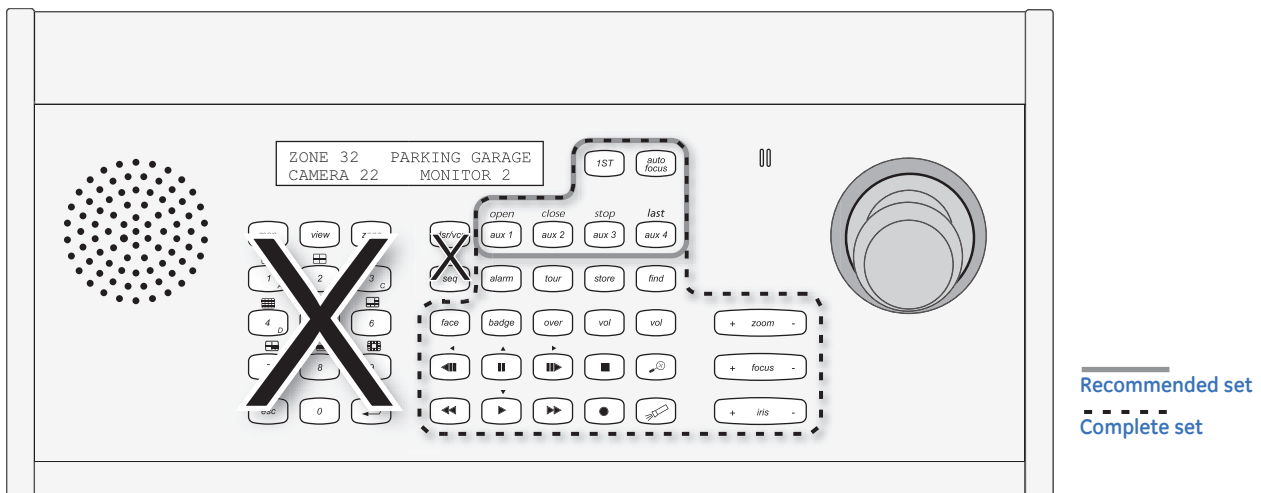

Table 10. Commands that can be assigned to reprogrammed keys

ALARM	FIND	LOCK	STEP
ALT	FIRST	MACRO (for future use)	STEP FWD
AUTO FCS	FLIP	MAGNIFY	STEP REV
AUTO PAN	GROUP	OPEN	STOP RCD
BADGE	HOME	OPEN 1	STORE (for future use)
BKLT BRT	IRIS CLS	OPEN 2	TALK
BKLT DIM	IRIS OPN	OVER	TOUR
BLNK/AUX	JOY CCW	PAUSE	UNLOCK
CARD	JOY CW	PLAY	VIEW
CLOSE	JOY DOWN	RECORD	VOL DOWN
DOOR 1	JOY LEFT	REWIND	VOL UP
DOOR 2	JOY RGT	SEARCH	ZONE
FACE	JOY UP	SHADOW	ZOOM IN
FAST FWD	LAST	SITE DWN	ZOOM OUT
FAST/AUX	LENS RST	SITE UP	0 LUX
FCS FAR	LIGHT	SLOW/STOP	NOTHING
FCS NEAR	LIVE	STABILIZ	

Index

A		K	
access code.....	26	key assignments.....	25
annunciation.....	30, 33, 47	keypad operation.....	38
audio.....	47	M	
audio attenuation.....	18	monitor selection.....	41, 48
autopan limits.....	44	multiple keypads connections.....	63
B		multiplexer control.....	44, 49
back panel connections.....	10	O	
baud rate.....	26	operating mode.....	5
C		<i>Digiplex</i>	5
camera control.....	42, 48	<i>zone</i>	6
camera selection.....	41, 48	P	
connections		preface.....	1
<i>back panel</i>	10	presets.....	24, 42
<i>I/O box</i>	12, 61	product	
<i>multiple keypads</i>	15	<i>contents</i>	4
<i>multiplexer</i>	14	<i>overview</i>	4
<i>RJ cable</i>	12	programming.....	20
<i>twisted pair</i>	13	<i>remote</i>	23, 34
conventions.....	1	<i>supervisor</i>	20
D		<i>user</i>	28
Digiplex mode.....	5, 41	<i>zone</i>	30
<i>hybrid</i>	5	programming modes.....	20
<i>standard</i>	5	<i>remote device</i>	20
G		<i>supervisor</i>	20
group switching.....	43	<i>user</i>	20
H		R	
help menu.....	46	recording device.....	45
hybrid mode.....	5	reprogrammable keys.....	67
I		S	
inactive timeout.....	27	safety terms and symbols.....	1
installation guidelines.....	8	site address.....	65
I/O box connections.....	12, 61	soft keys.....	26, 67
		standard mode.....	5
		system configuration.....	58

T

technical support 56
technical support centers 56
troubleshooting 53

Z

zone mode 6, 48