



# INSTRUCTION MANUAL

Part number 10768, REV 1292

## ESL 445D SERIES PHOTOELECTRONIC SMOKE DETECTORS

MODEL	DESCRIPTION
445DRT	Smoke detector with extra Form C alarm contact set and 135°F heat sensor
445DSRT	Smoke detector with extra Form C alarm contact set, 135°F heat sensor, and solid state horn, 85 dBA @ 10 ft.

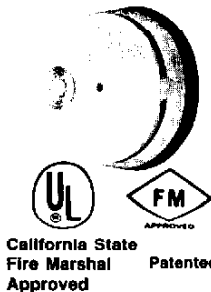

### GENERAL DESCRIPTION

ESL 445D Series are photoelectronic, four-wire system smoke detectors operating on the light-scattering detection principle. 445D Series smoke detectors are suited for commercial, industrial and institutional fire alarm systems.

The detector is intended for four-wire connection to UL Listed 120 volt AC fire alarm control units. Each detector has one Form A (SPST-NO) alarm relay contact for connection to an alarm initiating circuit, and an additional alarm contact set (Form C SPDT), *Listed as suitable for releasing service*, for auxiliary functions. Each unit also includes an integral heat sensor rated at 135°F.

Model 445DSRT has a built-in solid state horn rated at 85 dB @ 10 feet. The 85 dB sounder emits a steady tone whenever the detector alarms. These models are especially suited for occupancies such as hotels, motels and dormitories where efficient distribution of the alarm signal is essential.

### INSTALLATION

The 445 Series smoke detectors mount to standard single-gang electrical boxes, 4" octagonal (e.g., RACO #125 or equivalent) electrical boxes, or on WIREMOLD No. 5739 fixture boxes. The volume of the electrical box is determined by the number and size of conductors as required by the National Electrical Code (NFPA 70). All wiring must be installed in compliance with the NEC or the local code(s) having jurisdiction.

All field wiring connections are made to a terminal block on the printed circuit board. Access this area by inserting the blade of an 1/8" screwdriver in the small slot on the detector base, opposite the hinge. Gently depress the cover release tab, and swing the cover open. Remove the terminal block cover by gently pulling straight out. Dress all system wiring through the opening in the base of the smoke detector. Secure the detector to the mounting surface using the appropriate mounting holes and hardware. Strip 3/8" of insulation from each conductor and insert under the appropriate screw terminal. The barrier-type terminal block will accommodate one wire of 14 AWG to 22 AWG under each side of each screw/clamping plate. This design prevents "looping" of wires and provides for supervision of conductors. See Diagram #2 WIRING for correct terminal usage.

CHECK ALL WIRING AND MOUNTING CONNECTIONS. Dress wiring neatly and re-install the terminal block cover. Close and securely latch the detector cover.

**NOTE:** Positive air pressure from wire openings, conduit, mounting boxes, irregular mounting surfaces, or plenums causing air movement through and away from the detector may prevent proper operation. Seal all such openings causing unwanted air flow using UL Listed expanding foam or Duxseal.

### TESTING THE INSTALLATION

After all connections are complete and the wiring is checked for errors, apply power to the system. There should be no alarm. If an alarm is reported, check to verify if an actual alarm has occurred or if there is a problem with the installation. If it is not an actual alarm, power down the system and check each detector for correct wiring. If no alarm has occurred, check each detector's LED to verify that it is pulsing at approximately one pulse every seven seconds. Go to the last detector and check the smoke detector power with a volt meter for the specified voltage.

To test each detector for alarm operation, use canned smoke, a smoldering punk stick or cotton wick. If canned smoke is used follow manufacturer's directions carefully to prevent damage to the detector. For smoldering punks or cotton wicks, hold smoke source near the smoke entry and gently direct smoke into the detector. Continue for up to 20 seconds or until an alarm is indicated. **BE SURE TO PROPERLY EXTINGUISH THE SMOKE SOURCE AFTER TESTING!**

This is a gross test and is not a reliable indication of the sensitivity of the detector. If it is a successful test the LED will light steady. To reset the detector, operate the system reset switch for 2 to 3 seconds to remove power from the detectors. Control unit alarm and all ancillary functions should be verified for a complete test of each detector. Follow this procedure for the remaining detectors.

**TEST EVERY DETECTOR FOR PROPER OPERATION.** This testing procedure should be conducted annually by qualified personnel. If a detector fails to function properly, obtain a Return Authorization Number by calling 1-800-648-7422 or 503-620-8540, then carefully pack it and return it prepaid to the manufacturer. Include an explanation of the suspected failure mode.

### SENSITIVITY MEASUREMENT

The actual sensitivity of a detector may be determined by testing in a correlated UL 217/268 smoke test chamber. For a nominal charge ESL will perform this test and, if a detector is found to be outside of the marked sensitivity range, will clean the detector.

Contact ESL Customer Service for details on the return of the product. As an alternate to the above procedure, the Gemini Model 501 Aerosol Generator may be used. Follow the operating instructions supplied with the Gemini. Adjust the Gemini flow meter setting to the lower value in the table below. No alarm should occur with this value. Now adjust the Gemini setting to the higher value and re-conduct the test. The detector should alarm to the second test.

#### GEMINI FLOW METER SETTINGS

	Sensitivity	Flow Meter Setting
400 SERIES	3.1 + 0.5%/ft.	85
Photoelectronic Detectors	3.1 - 0.5%/ft.	74

Sensitivity measurements should be taken on all detectors towards the end of the first 12 months of operation, and every 24 months subsequent.

If a detector responds incorrectly, contact ESL Customer Service for details on the return of the product.

### APPROVALS

The smoke detector is for use in commercial fire protective signaling systems (NFPA 71, 72A, 72B, 72C, or 72D) and in household fire warning systems (NFPA 74).

Listed by Underwriters Laboratories, Inc.; California State Fire Marshal approved (Listing #7257-447:104); Factory Mutual approved (J.I.OK789.AY); State of Maryland approved (Permit #1885); City of Cleveland approved (Docket S-5-88); New York City, Board of Standards and Appeals approved (Calendar #122-73-SA).

### SUPERVISION OF SYSTEM WIRING

The detector's power is supervised by installing a power supervision unit for the appropriate control unit voltage at the end of the detector power circuit. The contacts of the supervision unit are wired in series with the system's alarm initiating circuit, and are closed when energized.

A break in the detector power circuit or a loss of power de-energizes the power supervision unit, opening the contacts and causing a trouble annunciation at the fire alarm control unit. See Diagram #2.

### MAINTENANCE

The 445 Series smoke detectors are designed to require little maintenance. Once a year (more often in dusty environments), open the detector cover and use a vacuum and/or filtered compressed air to loosen and remove dust from the screen surrounding the optical sensing mechanism. For detectors installed in hostile (dusty) environments, it may be necessary to purge the chamber with canned or clean, dry compressed air. It is important to notify all concerned parties when any maintenance or testing of a fire alarm system is to occur. Always test each detector after cleaning.

**DO NOT** attempt to adjust or alter the detector.



## ELECTRICAL SPECIFICATIONS

### SMOKE DETECTORS—All Models

Operating Voltage	120 VAC 60 Hz
Current	30 mA
Contact Rating (resistive)	2 Amperes @ 30 VDC or 120 VAC

### POWER SUPERVISION UNITS MODEL 910-5

Operating Voltage	120 VAC 60 Hz
Operating Current	16 mA
Contact Rating (resistive)	1 Ampere @ 30 VDC or 120 VAC

## OPERATIONAL DATA

Operating Temperature Range	0°C to 50°C; 32°F to 120°F	
Operating Humidity Range	0 to 95% RH	
Detector Size:	Diameter	6.1 in. 15.5 cm
	Height	2.0 in. 5.0 cm
	Weight	8.8 oz. 0.25 kg
Power/Alarm Indicator LED	Standby — Flashing Alarm — Steady	
Electronic Alarm Latch	Reset by momentary power interruption	
Sensitivity to Smoke	3.1 ± 0.5%/ft.	

## INSTALLATION (Diagram #1)

### FLUSH MOUNTING ON 4" OCTAGON BOX

See Note (Below)

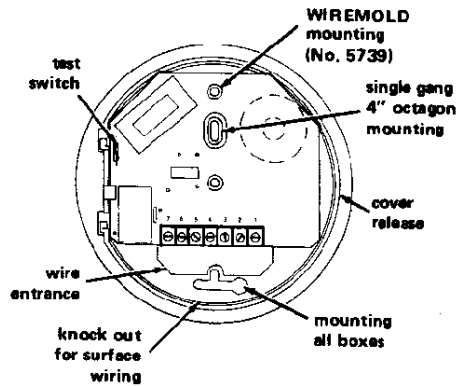
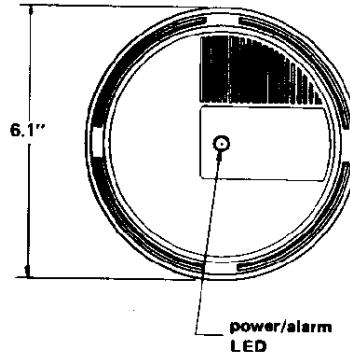
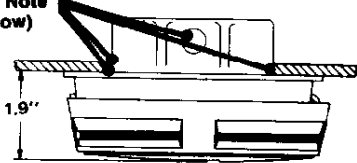

**NOTE:** Positive air pressure from wire openings, conduit, mounting boxes, irregular mounting surfaces, or plenums causing air movement through and away from the detector may prevent proper operation. Seal all such openings causing unwanted air flow using UL Listed expanding foam or Duxseal.

## WIRING CONNECTIONS (Diagram #2)

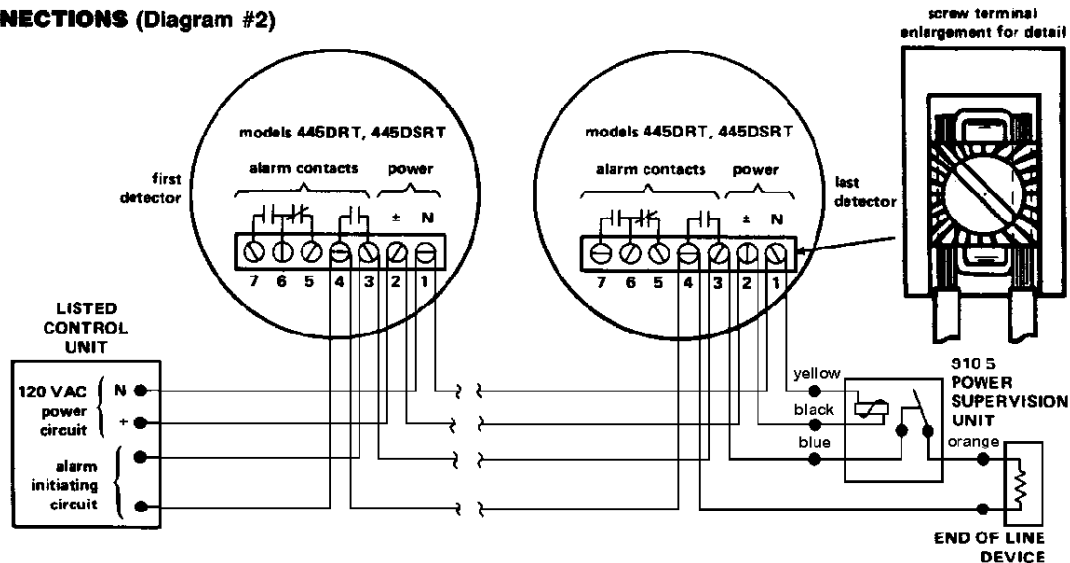

**Emergency operation [Style D (Class A)]:** Return initiating circuit wiring to appropriate control unit terminals and connect the end of line devices per the control unit instructions.

**CAUTION:** DO NOT use looped wire under screw terminals. These terminals are designed to prevent looping of an unbroken wire around or under a terminal screw in a manner that would permit the looped wire to remain unbroken during installation. This would preclude supervision if the wire were to dislodge from the terminal.

## SMOOTH CEILING SPACING

On smooth ceilings, spacing of 30 feet (9.1 meters) may be used as a guide. Other spacing may be used depending on ceiling height, high air movement, and other conditions or response requirements.

In all installations, good engineering judgment should govern.



**ELECTRO SIGNAL LAB, INC.**  
75 Terry Drive, Hingham, MA 02043  
Sales 1-800-225-8632  
Literature 1-800-648-7423  
Inside Massachusetts 617-740-3800

For more information on ESL 445 Series smoke detectors, including application information and detailed performance data, cleaning instructions, sensitivity verification procedure, and recommendations on spacing and placement, read Technical Bulletin 2282-TB "445 SERIES PRODUCT GUIDE."

Consult National Fire Protection Association Publications, "NFPA 72E, Standard on Automatic Fire Detectors," and, where applicable, "NFPA 74, Standard for the Installation, Maintenance, and Use of Household Fire Warning Equipment."