

# ID Repeater Daughter Board 600-1031 Installation Instructions

## Description

The ID Repeater Daughter Board mounts directly onto any frequency OEM transceiver module and converts the transceiver into a repeater. The purpose of the repeater is to receive and retransmit signals from wireless sensors, wireless touchpads, and other repeaters.

## Installation guidelines

Observe the following guidelines when installing the ID Repeater Daughter Board and OEM transceiver module:

- Allow at least 9 inches (22.9 cm) of clearance above the enclosure for the antennas.
- Avoid mounting locations that expose the module to moisture.
- Avoid areas with excessive metal or electrical wiring including furnace and utility rooms. If unavoidable, mount on or near metal with the antenna extending above the metallic surfaces as shown in Figure 1 below.

**Figure 1: Mounting on or near metal**

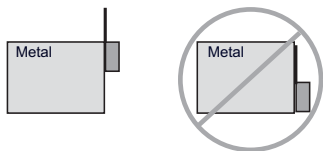

## Installation

To mount the ID Repeater Daughter Board, do the following:

1. Insert the plastic standoffs supplied with the daughter board into the standoff holes (Figure 2 below) on the daughter board.

**Figure 2: ID repeater daughter board**

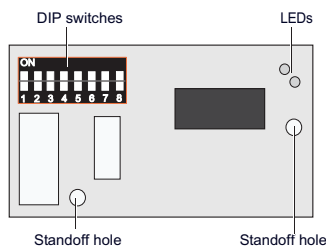

**Caution:** You must be free of static electricity before handling circuit boards. Wear a grounding strap or touch a bare metal surface to discharge static electricity.

2. Mount the ID Repeater Daughter Board onto the OEM transceiver module as shown in Figure 3 below.

**Figure 3: ID Repeater Daughter Board mounted on the OEM transceiver**

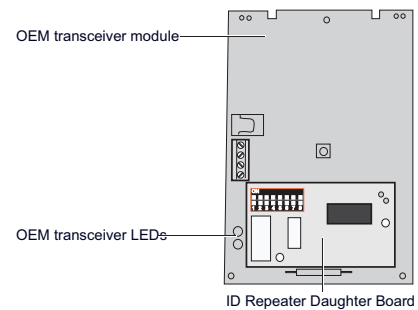

To mount the 600-1029 enclosure, follow the installation instruction provided with the enclosure.

To mount the OEM transceiver module onto the back plate of the 600-1029 enclosure (Figure 4 on page 2), do the following:

1. Insert the antennas into the antenna shrouds.
2. Gently slide the top of the OEM transceiver module under the two top latches.
3. Snap the OEM transceiver module in at the bottom latch to secure it in place.

**Figure 4: OEM transceiver module mounted in the 600-1029 enclosure**

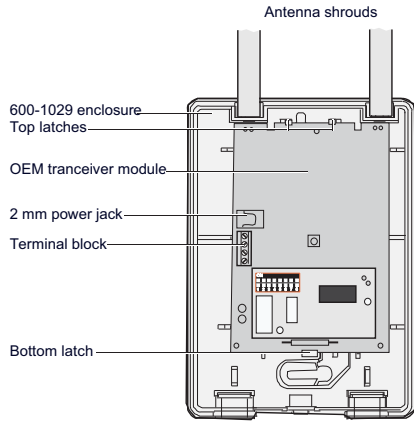

4. Connect DC power to the OEM transceiver module using a 2 mm power jack (center positive), or connect flyleads to the terminal block as labeled on the board.

## LED operation

Table 1 below shows the LED indications for the OEM transceiver module.

**Table 1: OEM transceiver module LED indications**

Indication	Green LED	Red LED
Powered up	On	Off
Communication with daughter board	On	Flashing
Valid packet received	On flash off	Off or flashing

Table 2 below shows the LED indications for the ID Repeater Daughter Board.

**Table 2: IRepeater Daughter Board LED indications**

Indication	Green LED	Green LED	Red LED
Power up	Power up	Flashes version*	On
Run		On steady	Off
Run error		Off	On
Run	Packet in to be repeated	One flash off	Off
Enroll		Long flashes	Off
Enroll	Pocket in, sensor enrolled	Long flashes	One long flash
Enroll	Pocket in, repeater enrolled	Long flashes	Two long flashes
Enroll	Tamper hit, sensor removed	Long flashes	One long flash
Enroll	Tamper hit, repeater removed	Long flashes	Two long flashes
Delete		Long flashes	Quick flashes
Delete	Packet in, sensor removed	Long flashes	One long flash

Delete	Packet in, repeater removed	Long flashes	Two long flashes
Delete all			Quick flashes
Delete all	Tamper hit, all removed	Long flashes	Long flashes

\* When flashing the version, a long flash indicates a 1 and a short flash indicates a 0.

## Modes of operation

The unit has the following modes of operation:

- **Smart mode** - The ID Repeater Daughter Board only retransmits signals from sensors and repeaters that have been enrolled into memory (up to 127 sensors and 4 repeaters). Smart mode is the recommended mode of operation and is enabled when the repeater number is set to a non-zero number.
- **Dumb mode** - The repeater retransmits signals heard from any sensor, but does not repeat signals from other repeaters. You can only have one dumb mode repeater per installation.

## Configuration

Table 3 below shows how to configure the modes of operation.

**Table 3: Repeater configuration**

Action	OEM tamper	DIP switches							
		1	2	3	4	5	6	7	8
Run mode	N/A	X	X	0	Repeater number				
Program mode	Open	X	X	1	Repeater number				
Enroll mode	Open	0	0	1	Repeater number				
Delete last device enrolled*	Press to delete	0	0	1	Repeater number				
Delete mode	Open	0	1	1	Repeater number				
Delete all	Press to delete	1	0	1	Repeater number				
Disable unlearned panic repeat	Press to disable	1	1	1	0	0	0	1	0
Enable unlearned panic repeat	Press to enable	1	1	1	0	0	0	1	1
63-bit mode	Press to set mode	1	1	1	0	0	1	0	0
63/80-bit mode	Press to set mode	1	1	1	0	0	1	0	1

\*Only deletes device during current enrollment session.

**Selecting 63-bit only** - Only 63-bit signals are transmitted and the repeater status is reported via 63-bit packets. This mode can be used while operating in either smart or dumb modes.

**Selecting 63/80-bit** - 63-bit and 80-bit signals are retransmitted and the repeater status is reported via 80-bit packets. This mode can only be used in conjunction with smart mode. Refer to the sensor's installation manual to determine if 63 or 80-bit format is appropriate for a particular sensor.

## Setting the repeater number

By setting a repeater number to a unique, non-zero number using DIP switches 4 to 8, you enable the repeater for smart mode operation (see Table 4 below).

**Note:** When the repeater is operated in 63/80-bit mode, the repeater number is limited to 1 through 15.

**Table 4: Repeater number DIP switch settings**

Repeater number	DIP switches				
	4	5	6	7	9
0	0	0	0	0	0
1	0	0	0	0	1
2	0	0	0	1	0
3	0	0	0	1	1
4	0	0	1	0	0
5	0	0	1	0	1
6	0	0	1	1	0
7	0	0	1	1	1
8	0	1	0	0	0
9	0	1	0	0	1
10	0	1	0	1	0
11	0	1	0	1	1
12	0	1	1	0	0
13	0	1	1	0	1
14	0	1	1	1	0
15	0	1	1	1	1
16*	1	0	0	0	0
17*	1	0	0	0	1
18*	1	0	0	1	0
19*	1	0	0	1	1
20*	1	0	1	0	0
21*	1	0	1	0	1
22*	1	0	1	1	0
23*	1	0	1	1	1
24*	1	1	0	0	0
25*	1	1	0	0	1
26*	1	1	0	1	0
27*	1	1	0	1	1
28*	1	1	1	0	0
29*	1	1	1	0	1
30*	1	1	1	1	0
31*	1	1	1	1	1

**Note:** \*Not a valid repeater number when operated in 63/80-bit mode.

**Note:** 1 = DIP switch up (On), 0 = DIP switch down (Off)

## Sensor/repeater enrollment

To enroll the sensor or repeater, do the following:

1. Place the repeater into enroll mode by placing DIP switch 3 into the on position (Table 3 on page 2). The ID Repeater Daughter Board's LEDs flash to indicate the mode has been entered. (Table 2 on page 2).
2. Trip the enrollment mechanism for each sensor/repeater (Table 5 below). The ID Repeater Daughter Board's red LED flashes to indicate successful enrollment (Table 2 on page 2).
 

**Note:** The last sensor/repeater enrolled may be deleted by pressing the OEM receiver's tamper switch. Other repeaters can only be enrolled if their repeater number is greater than the repeater number of the enroller.
3. Return all ID Repeater Daughter Board DIP switches to the run mode positions (Table 3 on page 2).

## Delete sensors/repeaters

To delete sensors or repeaters, do the following:

1. Place the repeater into delete mode by placing DIP switches 2 and 3 into the on position (Table 3 on page 2). The ID Repeater Daughter Board's LEDs flash to indicate the mode has been entered (Table 2 on page 2).
2. Trip the enrollment mechanism for each sensor/repeater (Table 5 below). The ID Repeater Daughter Board's red LED flashes to indicate the sensor/repeater was successfully deleted (Table 2 on page 2).

## Delete all

To clear the memory of all enrollments, do the following:

1. Place the repeater into delete all mode by placing DIP switches 1 and 3 into the on position (Table 3 on page 2). The ID Repeater Daughter Board's LEDs flash to indicate the mode has been entered (Table 2 on page 2).
2. Press and release the OEM transceiver module's tamper switch. The ID Repeater Daughter Board's red LED flashes to indicate the memory was cleared (Table 2 on page 2).

**Table 5: Enrollment mechanism**

Transmitter	Action
Sensors	Remove cover/base or press and release tamper switch.
Keychain touchpad	Press lock and unlock buttons simultaneously.
Other touchpad	Bypass button.
Receiver	Remove cover or press and release tamper switch.

## Testing

The receive and transmit tests should be done prior to permanently mounting the repeater, but after programming is completed.

**Note:** It takes two people to do the following tests due to the distance between devices.

## Receive test

To test that the repeater is receiving information, do the following:

- Force each device that is intended to operate with the repeater to transmit. The green LED on the OEM transceiver module located directly below the terminal block will flash for each packet received. The ID Repeater Daughter Board's green LED will also flash if:
  - The ID Repeater Daughter Board is in the dumb mode, or
  - The ID Repeater Daughter Board is in the smart mode **and** the sensor/repeater tripped is enrolled.
- Verify that at least 7 of 8 (14 of 16) of the packets are received. The number of packets may vary depending on the type of device (Table 6 below).

## Transmit test

To test that the repeater is transmitting information, do the following:

- Force the repeater to transmit by either pressing the tamper switch or tripping an enrolled device.
- Verify that at least 7 of 8 (14 of 16) of the packets are received by the panel or another repeater. The number of packets may vary depending on the type of devices (Table 6 below).

**Table 6: Number of packets sent per device type**

Device	Trigger	Number of packets
Door/window sensor	Remove magnet cover	8
Keychain touchpad	Press lock and unlock simultaneously	8
Other touchpads	Press and hold emergency buttons	8
Panic button	Press and hold 5 seconds, then release	16
PIR motion sensor	Remove from mounting plate	8
Repeater	Press and hold tamper for 5 seconds, then release	16
Smoke sensor	Press and hold test button for 20 seconds	8

## Troubleshooting

The following tables give troubleshooting suggestions for the OEM transceiver module and the ID Repeater Daughter Board.

**Table 7: OEM transceiver module troubleshooting**

Problem	Action
OEM transceiver module's green and red LEDs are off	1. Check that the transformer is plugged in. 2. Check the transformer to module wiring.
OEM transceiver modules' green LED is on and red LED is off	Check the ID Repeater Daughter Board mounting.

**Table 8: ID Repeater Daughter Board troubleshooting**

Problem	Action
ID Repeater Daughter Board's green and red LEDs are off	1. Check that the transformer is plugged in. 2. Check the transformer to module wiring. 3. Check the ID Repeater Daughter Board mounting.
ID Repeater Daughter Board's green LED is off and red LED flashes slowly	1. Disconnect the transformer, verify the daughter board mounting and reconnect the transformer. 2. The ID Repeater Daughter Board is set to 63/ 80 and the repeater board's number is set to zero. Set the repeater board to a non-zero number.

## Specifications

Compatibility	OEM transceivers and wireless transmitters
Power requirements	Power supplied by OEM transceiver module (see appropriate OEM transceiver manual for details)
Wireless signal range	See appropriate OEM transceiver manual
Operating temperature	32 to 120°F (0 to 49°C)
Storage temperature	-30 to 140°F (-34 to 60°C)
Max. relative humidity	85% noncondensing
Dimensions (LxWxD)	6.5 in. x 4.6 in. x 1.25 in. (16.5 cm x 11.7 cm x 3.2 cm) excluding antennas

## Regulatory information

Manufacturer	UTC Fire & Security Americas Corporation, Inc. 1275 Red Fox Rd., Arden Hills, MN 55112-6943, USA
--------------	---

FCC compliance:

This device complies with FCC Rules Part 15. Operation is subject to the following two conditions:

- This device may not cause harmful interference.
  - This device must accept any interference that may be received, including interference that may cause undesired operation.
- Changes or modifications not expressly approved by UTC Fire & Security can void the user's authority to operate the equipment.

Certification



European Union directives:

We declare under our sole responsibility that this product is in conformity with Directive 93/68/EEC (Marking) and/or complies to the essential requirements and all other relevant provisions of the 1999/5/EC (R&TTE) based on test results using (non) harmonized standards in accordance with the Directives mentioned.

## Contact information

For contact information, see [www.utcfireandsecurity.com](http://www.utcfireandsecurity.com) or [www.interlogix.com](http://www.interlogix.com).

For technical support, toll-free: 888.437.3287 in the US including Alaska, Hawaii, Puerto Rico, and Canada. Outside the toll-free area, contact your dealer.

Copyright © 2011 Interlogix, a UTC Fire & Security Company. All rights reserved.