

TVJ-JBS Stainless Steel Junction Box Installation Instructions

Specifications

Dimensions: 248.7 × 174 × 77.5 mm
(9.79 × 6.85 × 3.05 in.)

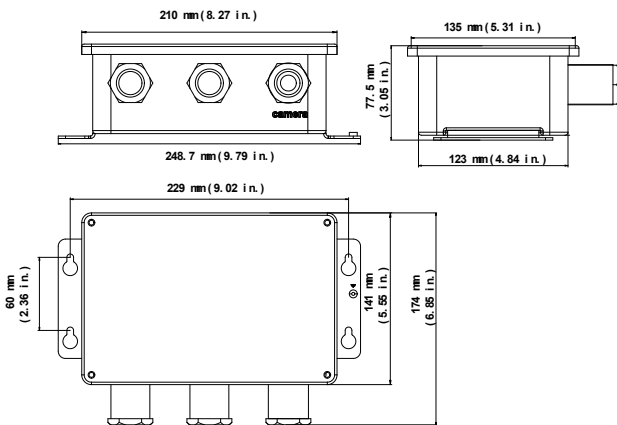

Weight: 1981 g (4.37 lb.)

Accessories:

Drill template: 1 pcs



Screw: PA5 x 25 mm (4 pcs)

Used to install the TVJ-JBS stainless steel junction box to the mounting surface.

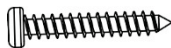

Drywall anchor: 7.5 x 24.5 mm (4 pcs)

Used to install the TVJ-JBS stainless steel junction box to the mounting surface along with the screw described above.



Torx wrench: 1 pcs

Used to remove and tighten the Torx screws on the cover of the stainless steel junction box.

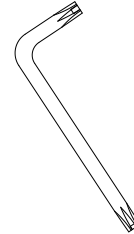

Sealing plug group A: 4 pcs

Used for the camera cable harness access hole. Plug color depends on cable diameter. Use the correct color for a tight seal.

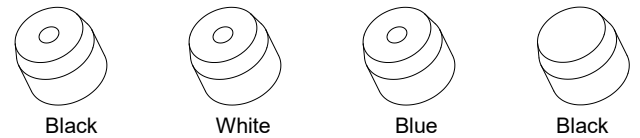

Sealing plug group B: 4 pcs

Used for the other two holes. Plug color depends on cable diameter. Use the correct color for a tight seal.

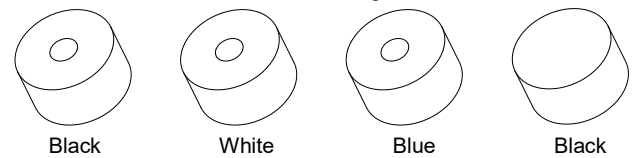

Supported Cameras

The stainless steel junction box can be used with following cameras:

Stainless Steel Box Camera Housing/Bullet:	TVB-5801, TVB-5802
Stainless Steel Dome:	TVD-5801

Installation

To install the junction box:

1. Drill mounting holes in the mounting surface according to the supplied drill template. Insert the four drywall anchors in the mounting surface. Partially tighten down the four mounting screws



2. Unscrew the four screws on the cover of the junction box and remove the cover.

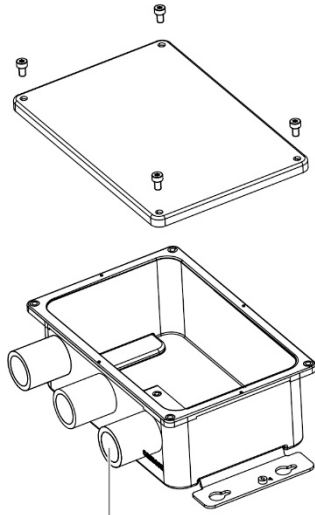

Camera cable harness access hole

3. Align the four slotted mounting holes on the junction box with the mounting hardware. Secure the junction box to the mounting surface.
4. Route the camera cable harness through the cable access hole on the junction box and tighten the waterproof nut.

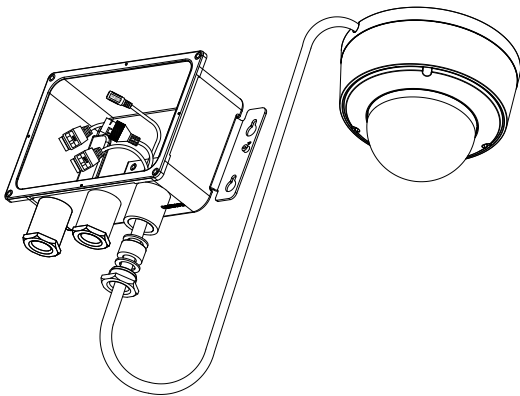

5. Use the other cable access holes in the junction box to route the cables into the junction box. Complete the connections.

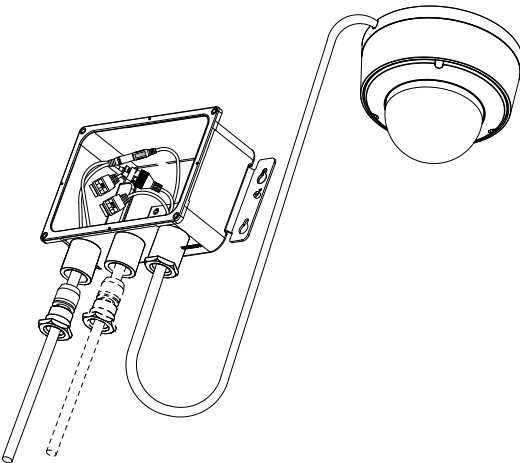

6. Tighten the sealing plug group A and group B after connecting the cables. Reattach the cover of the junction box.

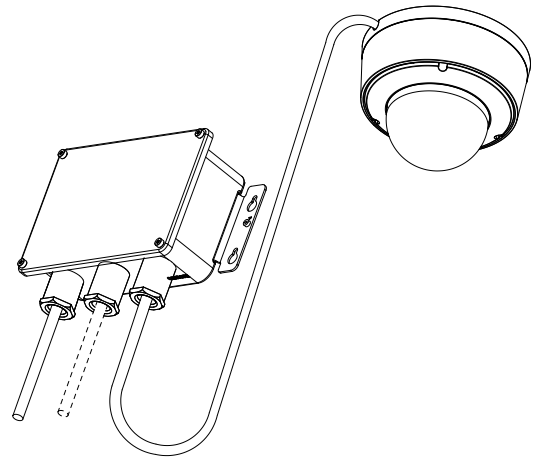

Legal and regulatory information

Trademarks and patents	The trade names used in this document may be trademarks or registered trademarks of the manufacturers or vendors of the respective products.
Manufacturer	Interlogix. 2955 Red Hill Avenue, Costa Mesa, CA 92626 5923, USA Authorized EU manufacturing representative: UTC Fire & Security B.V. Kelvinstraat 7, 6003 DH Weert, The Netherlands

Certification



Product warnings and disclaimers

THESE PRODUCTS ARE INTENDED FOR SALE TO, AND INSTALLATION BY, AN EXPERIENCED SECURITY PROFESSIONAL. UTC FIRE & SECURITY CANNOT PROVIDE ANY ASSURANCE THAT ANY PERSON OR ENTITY BUYING ITS PRODUCTS, INCLUDING ANY "AUTHORIZED DEALER", IS PROPERLY TRAINED OR EXPERIENCED TO CORRECTLY INSTALL SECURITY RELATED PRODUCTS.

For more information on warranty disclaimers and product safety information, please check www.firesecurityproducts.com/policy/product-warning/ or scan the following code:



Contact information and manuals / tools / firmware

For contact information and to download the latest manuals, tools, and firmware, go to the web site of your region.

Americas: www.interlogix.com

EMEA: www.firesecurityproducts.com

Manuals are available in several languages

Australia/New Zealand: www.utcfs.com.au