

## STEP 1 - MOUNTING

1. Determine the best location for the 3040/3050 based on the work habits of the end user and their physical reach. The 3040 should be placed such that the user would not call attention while activating the switch. Typical mounting positions are on the sides of desks in the kneehole area, or under counters away from view. The 3050 with its lit LED (green) is visible in low light environments or at night. The unit should be mounted within the line of sight, so that the LED is not obstructed. The device can be located in a hall, entryway or near a bedside. The lever must be oriented vertically or horizontally as shown in the illustrations below.

### Desk Mount

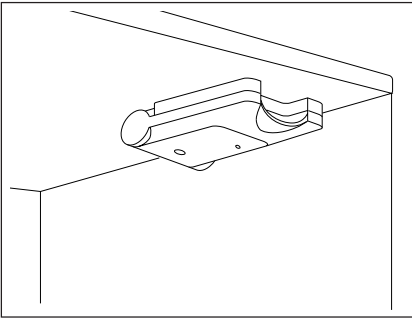

*Under Counter*

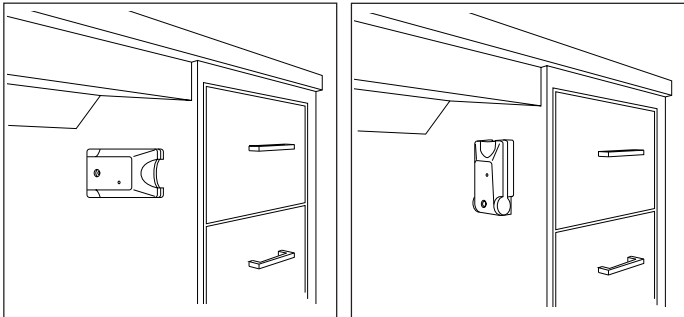

*Kneehole of Desk, Horizontal*

*Kneehole of Desk, Vertical*

### Freezer Mount



**IMPORTANT:** You must allow at least 3" (7.62cm) of clearance above the mounting surface to accommodate the actuating lever once it is fully open.

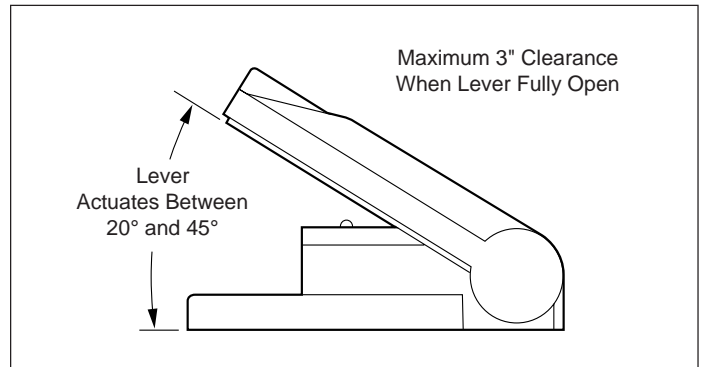

2. Temporarily position the unit where it will be mounted, and mark the screw holes and the hole for the leads.

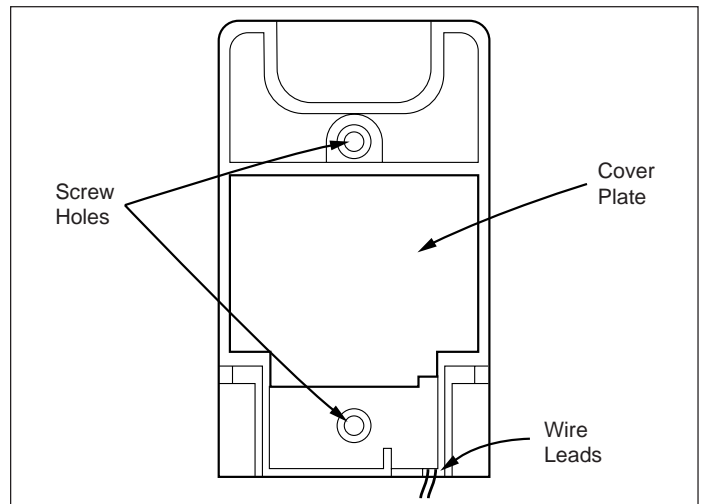

3. Drill pilot holes or start the screws. Connect the wire leads to the terminal block (see wiring diagram).

4. After the leads are wired, install cover plate by snapping it in place. Then, insert the screws through the switch housing and firmly secure unit into place.

## STEP 2 - WIRING

The wiring diagrams show two separate circuits: the SPDT circuit and the latching LED circuit. The latching LED must be powered and controlled by, respectively, a +12 VDC source in the alarm panel (24 hour switchable power loop or equivalent), and a normally closed push-button or spring-loaded momentary-action toggle switch inside or mounted outside the panel. Wire the reset circuit in series to the LED circuit as shown.

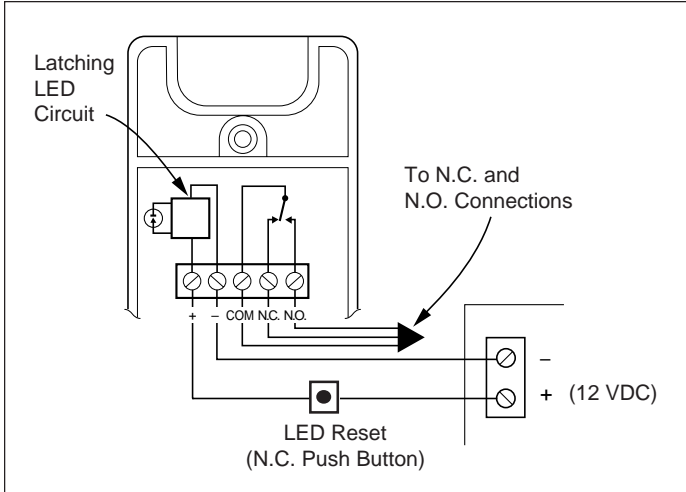

When the actuating lever is pulled between 20° to 45°, the alarm circuit switch (SPDT) will actuate. Then the LED will latch and light or change to red (3050), indicating that the SPDT switch has been activated. Closing the handle rearms the SPDT switch. However, the LED remains lit.

**IMPORTANT: The lever must be closed first to reset the SPDT circuit before the LED is reset.**

To test and rearm the SPDT switch, do the following:

1. Pull the handle down until the LED lights or changes to red (3050), indicating that the SPDT alarm circuit has been activated.

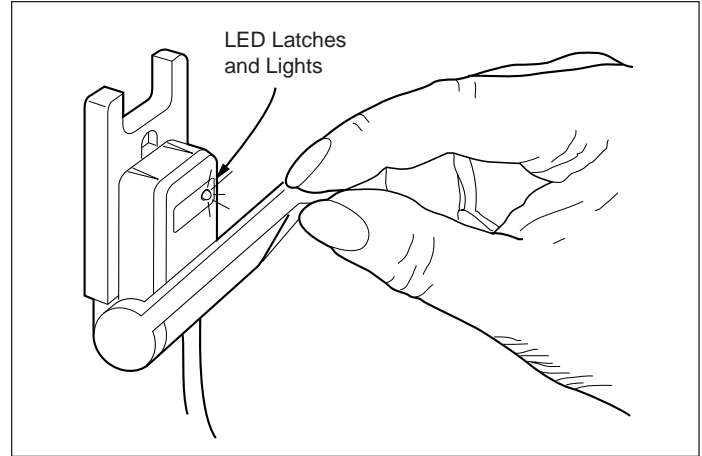

2. Close the handle. The SPDT switch is now fully re-armed. The LED remains lit.
3. Activate the normally closed push-button or toggle switch located at the master control panel to interrupt power to the latching LED. The LED will go out or change to green (3050).

## SPECIFICATIONS

Nominal Voltage .....	12 VDC @ 6mA
Operational Voltage .....	7 VDC - 15 VDC
Current Draw .....	Max 8mA
Temperature .....	0° to 110°F (-18° to 48°C)
Dimensions .	1.77" (4.50cm) W x 2.90" (7.37cm) L x .76" (1.93cm) D
Weight .....	1.5 oz.
Housing Material .....	ABS plastic

### Lead Colors for 3040CT, 3050CT Form C

Green	Common
Brown	Closed Loop (N.O.)
White	Open Loop (N.C.)
Red	Positive
Black	Negative

## ORDERING INFORMATION

Model Number	LED	Latching Circuit	Electrical Loop Type	Configuration	Color	Listed
3040	Red	Yes	Open or Closed	SPDT	White	UL
3040CT	Red	Yes	Open or Closed	SPDT	White	UL
3050	Bi-color	Yes	Open or Closed	SPDT	White	UL

\* European Union Specification: 48 V AC/DC Max., 0.5 Amp



SENTROL

### CORPORATE HEADQUARTERS

12345 SW Leveton Dr., Tualatin, OR 97062

Tel.: 503.692.4052 Fax: 503.691.7566

<http://www.sentrol.com>

**U.S. & Canada: 800.547.2556**

**Technical Service: 800.648.7424**

**FaxBack: 800.483.2495**

Sentrol reserves the right to change specifications without notice.

©1999 Sentrol

C-3732-0299  
14327 Rev B