

Fiber Optic Video Transmission System  
Models S700V and S702V

# installation instructions



**GENERAL**

This manual is a guide to the installation and operation of the S700V and S702V series fiber optic video transmission system. Please read the entire manual before installing the equipment.

**NOTE:** The series numbers S700V and S702V are used to describe all models unless noted otherwise.

The Series S700V and S702V video transmission system offers one-way transmission of video from a camera to a monitoring station over one or two fibers. The S700V is a multimode link using a single fiber, while the S702V is a multimode link using two fibers.

A complete system consists of either one or two transmitters and one or two receivers, depending on the model.

Units are designed for standalone operation or for installation in Fiber Options' 503H, 515R1 or 517R1 Card Cages.

**Unpacking the Unit**

In the event that anything is missing from the following list, contact your authorized Fiber Options dealer or representative.

S700VT or S702VT Transmitter(s) and S700VR or S702VR Receiver(s)  
Instruction manual

Save the original packing materials in case it becomes necessary to return the unit.

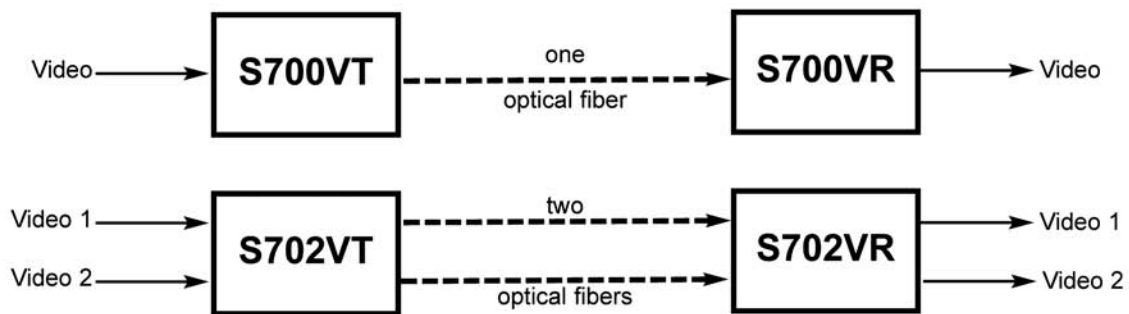
**BASIC SYSTEM DIAGRAMS**

See Figure 1 for additional system configurations.

FIGURE 1: ADDITIONAL SYSTEM CONFIGURATIONS

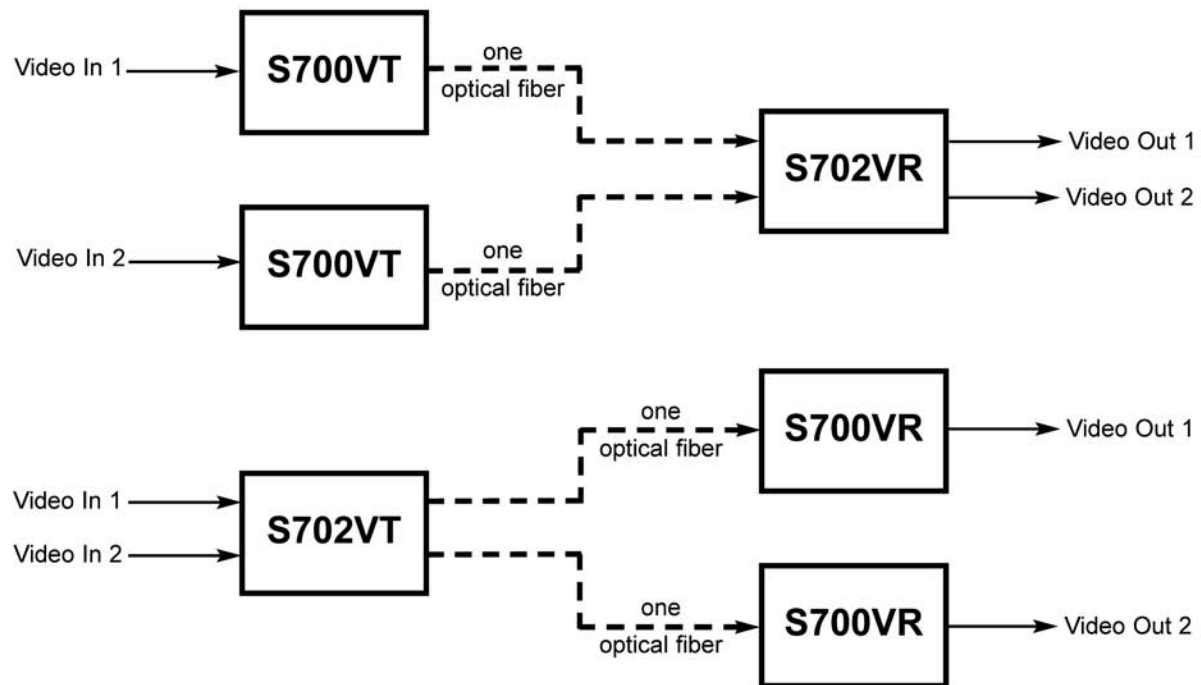

## INSTALLATION

### Installation Considerations

This fiber-optic link is supplied as a standalone module or as a rack card. Units should be installed in dry locations protected from extremes of temperature and humidity. The type of screws used for mounting must be suitable for the surface where a module will be mounted.

### Standalone Modules

Standalone modules are provided with a mounting plate with holes for two No. 6 flat head screws (3-mm or 3.5-mm). The type of screws must be suitable for the surface where a module will be mounted. See Figure 2.

1. Determine where the module will be installed, and ensure that there is adequate space at both ends for making the various cable connections and for reading the diagnostic LEDs.
2. Attach the mounting plate to a flat surface using two mounting screws. Once the plate is securely attached, align the tabs in the plate with the holes in the rear of the module and apply downward pressure until the module snaps in place.

### Rack Cards

Rack cards are designed to be installed in one of Fiber Options' 19-inch (483-mm) EIA standard card-cage racks, either the 503H, 515R1 or the 517R1. They may also be installed in one of the 501R, 502R, or 503R standalone rack card enclosures. Follow these guidelines to install rack cards.

**CAUTION:** Although rack cards are hot-swappable and may be installed without turning off power to the rack, Fiber Options recommends that the power switch on the rack power supply be turned OFF and that the rack power supply is disconnected from any power source.

1. Make sure that the card is oriented right-side up, and slide it into the card guides in the rack until the edge connector at the back of the card seats in the corresponding slot in the rack's connector panel. Seating may require thumb pressure on the top and bottom of the card's front panel.

**CAUTION:** Take care not to press on any of the LEDs.

2. Tighten the two thumb screws on the card until the front panel of the card is seated against the front of the rack.

FIGURE 2: STANDALONE MODULE MOUNTING PLATE

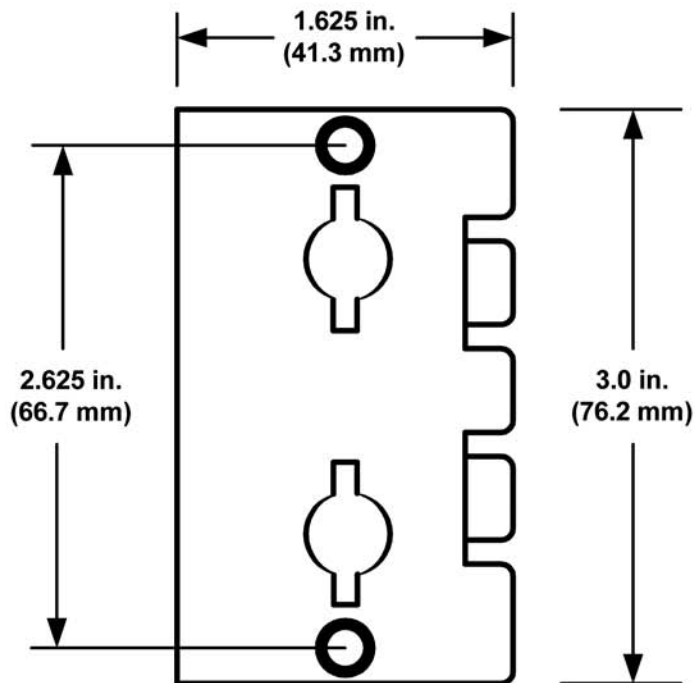

### 503H Horizontal Card Cage

**CAUTION:** The rack card module can only be powered by 13.5 VDC. AC power must not be used.

**CAUTION:** Fiber Options recommends that the card cage is not connected to any power source during installation.

1. Look inside the card cage to determine the location of the socket for the edge connector on the card. Orient the card so that it will seat in the socket, and slide it into the card guides in the card cage until the edge connector at the back of the card seats in the socket. Seating may require thumb pressure on the top and bottom of the card's front panel.

**CAUTION:** Take care not to press on any of the LEDs.

2. Tighten the two thumb screws on the card until the front panel of the card is seated against the front of the card cage.

### 501R, 502R and 503R Rack Card Enclosures

**CAUTION:** The rack card module can only be powered by 13.5 VDC. AC power must not be used.

**CAUTION:** Fiber Options recommends that the enclosure is not connected to any power source during installation.

1. Look inside the enclosure to determine the location of the socket for the edge connector on the card. Orient the card so that it will seat in the socket, and slide it into the card guides in the enclosure until the edge connector at the back of the card seats in the socket. Seating may require thumb pressure on the top and bottom of the card's front panel.

**CAUTION:** Take care not to press on any of the LEDs.

2. Tighten the two thumb screws on the card until the front panel of the card is seated against the front of the enclosure.

### CONNECTIONS

All fiber-optic links convert electrical signals into a light source at the transmitter and convert the light back to electrical signals for output at the receiver.

### Video Cable Connection

The S700V has one BNC connector and one fiber connector on the transmitter and receiver. The S702V has two BNC connectors and two fiber connectors. See Figures 3 and 4.

**FIGURE 3: STANDALONE MODULE CONNECTIONS**

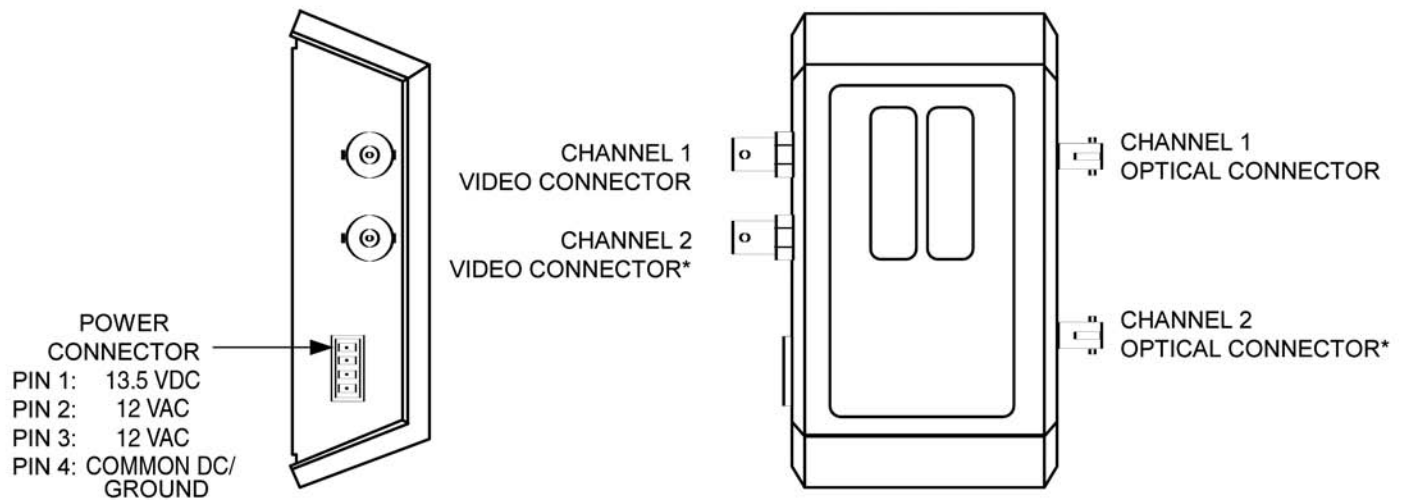

\* Channel 2 VIDEO and Channel 2 OPTICAL connectors are not present on S700VT single-channel transmitters. Units are identical otherwise.

**FIGURE 4: RACK-MOUNT MODULE CONNECTIONS**

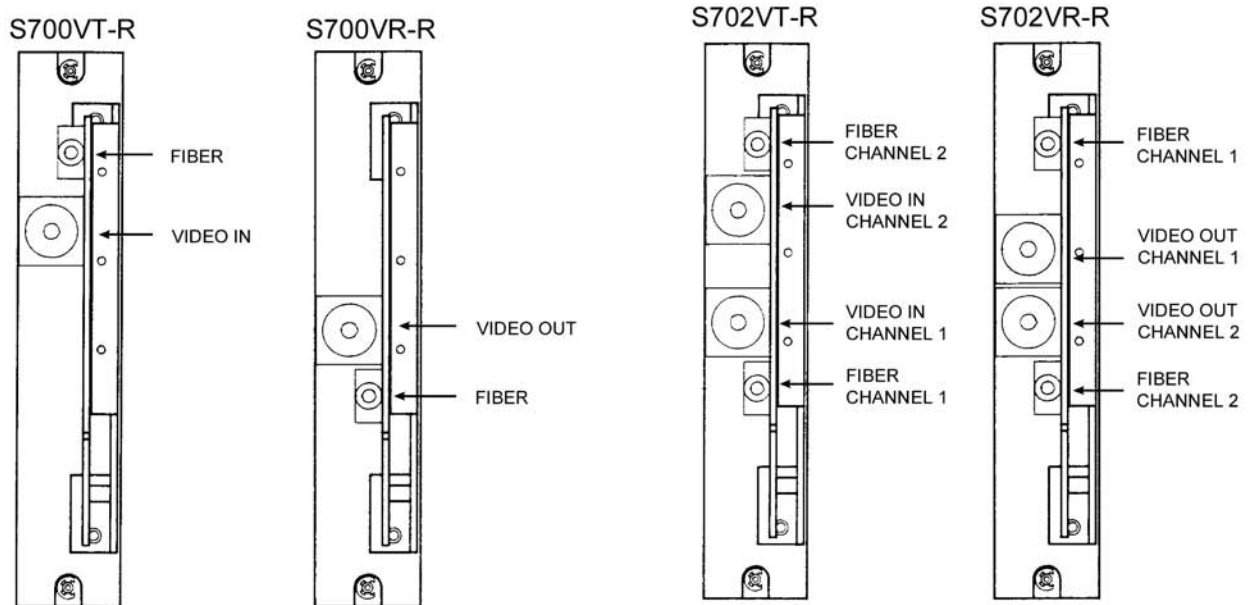



**CAUTION:** Make sure all peripheral equipment that will be connected to the fiber unit is turned OFF during installation.

Fiber Options recommends using Belden number 9259 or equivalent RG59/U coaxial cable between the video equipment and the fiber units. Do not exceed the maximum distance recommended by the manufacturer of the video equipment.

**NOTE:** Coaxial cable must be terminated with female BNC connectors to properly connect with the Fiber Options equipment.

Connect the video equipment, such as a camera, to the input BNC jack on the S700VT transmitter using terminated coaxial cable. Connect the monitoring equipment to the output BNC jack on the S700VR receiver with terminated coaxial cable. (The S702VT and S702VR units have BNC connectors for two video sources or monitors.)

### Fiber Optic Cable Connection

Most cable manufacturers identify the individual fibers in the cable. Select appropriately terminated fiber and mark both ends with unique identification label (e.g. for cable no. 03, fiber no. 08) to ensure that the fiber connected to the near end is the same one that is connected to the far end. The proper optical connection will link the transmitter's TRANSMIT (OUT) port to the receiver's RECEIVE (IN) port. See Figures 3 and 4.

1. Wipe the inside of the port's sleeve with a lint-free pipe cleaner moistened with reagent-grade isopropyl alcohol. Blow dry with dry air.
2. Clean the connector using a lint-free cloth dampened with alcohol to thoroughly wipe the side and end of the ferrule. Blow the ferrule dry with dry air. Visually inspect the ferrule for lint.
3. Fasten the fiber optic cable to the port. As a convenience to the installer, one-fiber units have been fitted with an angled optical connector to permit easy access.

### Power Connections

#### Standalone Modules

Standalone units may be powered either by 12 VAC or by 13.5 VDC. Standalone modules have a removable screw terminal connector for the electrical input connection.

Refer to Table 1 for the 501R and 503H rack card enclosures and Figure 3 for standalone units.

1. Identify the power connector and remove it from the module.
2. Make sure the power supply is not connected to any power source, and strip approximately 0.25-in (6-mm) of insulation from the ends of the cable.
3. Taking care to observe the correct polarization of the cable, insert one lead into one of the screw sockets and tighten the screw. Repeat for the other conductor. Confirm the security of the connection by a light pull on the cable.
4. Seat the connector in its position in the fiber unit.
5. Plug the power supply into a suitable outlet.

**CAUTION:** The rack card module can ONLY be powered by 13.5 - 16 VDC. AC power must not be used.

Power up the peripheral equipment and verify system operation by observing video on the monitor at the receiver end.

### Rack Modules

Power connections are made automatically when the card is installed. To supply power to the rack, connect the rack power supply to an AC outlet and set the power switch to ON.

### SMARTS™ DIAGNOSTICS

The S700V has built in Status Monitoring And Reliability Test System (SMARTS™) diagnostic capabilities that includes LED indicators for monitoring video and optical status. They are described in the following sections.

#### LED Operation

The S700V has 2 LED indicators that are very useful in describing the current state of operation, as well as the fiber optic signal strength. These indicators are LEVEL/LOSS™ and VIDEO. See Figure 5. They function as follows:

#### LEVEL/LOSS™ Indicator

This LED is useful for indicating the relative optical signal strength at the fiber optic receiver. When sufficient optical power is being received, the LED is green. If no or insufficient optical power is received, the LED will be red.

**TABLE 1: STANDALONE ENCLOSURE POWER CONNECTIONS**

Pin	Connection
1	Ground
2	Not Used
3	DC +

**FIGURE 5: RACK-MOUNT MODULE BEZELS**

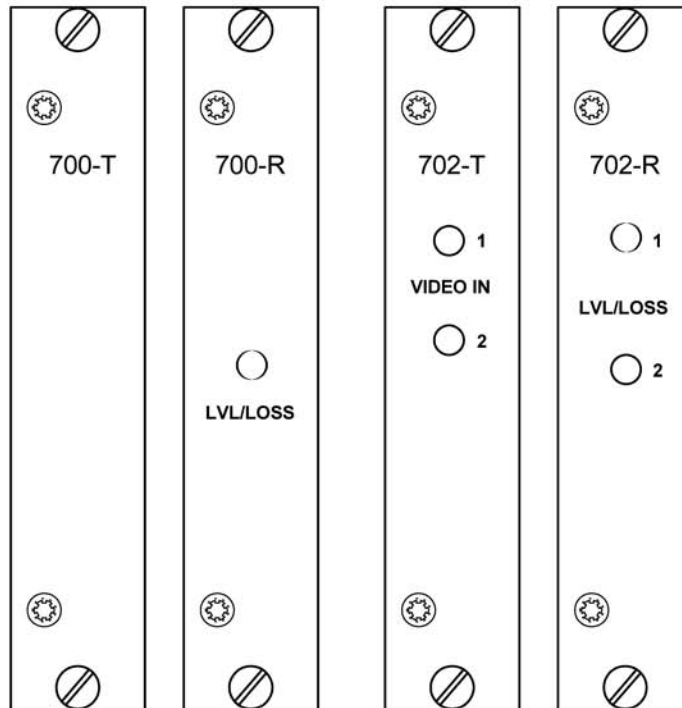

**VIDEO Indicator**

The VIDEO LED on the transmitter indicates the presence of a video signal. It will remain green as long as an adequate video signal is being input to the transmitter.

The LED will be red when no video signal is present.

**NOTE:** A blank video screen can be a valid video input.

If the S700V fails to operate and the cause of the failure cannot be determined, it may be necessary to contact Fiber Options.

**OPERATION**

S700V and S702V links operate automatically once installed. Refer to the Table 2 for an explanation of how to diagnose system faults using the LEDs built into the Fiber Options units. For an explanation of LED color codes, refer to LED Operation on page 5.

**MAINTENANCE**

There is no operator maintenance other than keeping the units clean.

TABLE 2: LED DIAGNOSTIC INDICATORS

LED Name	Color	Indicates/Corrective Action
LEVEL/ LOSS	Green	Sufficient optical power received. <i>No action required.</i>
	Red	Insufficient optical power received. <i>Verify fiber connected &amp; within optical budget, transmitter and receiver power on.</i>
VIDEO	Green	Valid video signal at unit. <i>No action required.</i>
	Red	No video signal at unit. <i>Verify video connected, video source has power and is transmitting.</i>

## Customer Support

For assistance in installing, operating, maintaining, and troubleshooting this product, refer to this document and any other documentation provided. If you still have questions, please contact technical support during normal business hours (Monday through Friday, excluding holidays, between 6 a.m. and 5 p.m. Pacific Time).

### GE Security

Call: 888 437-3287 (US, including Alaska and Hawaii; Puerto Rico; Canada)

Outside the toll-free area: 503 885-5700

Fax: 561 998-6224

[www.gesecurity.com](http://www.gesecurity.com)



GE Security

[www.GESecurity.com](http://www.GESecurity.com)

#### U.S.

T (561) 998-6100

T 888-GE-SECURITY

888 (437-3287)

F 561 998-6224

E [gesecuritycustserv@ge.com](mailto:gesecuritycustserv@ge.com)

#### Asia

T 852-2907-8108

F 852-2142-5063

#### Australia

T 613-9239-1200

F 613-9239-1299

#### Canada

T 519-376-2430

F 519-376-7258

#### Europe

T 44-113-238-1668

F 44-113-253-8121

#### Latin America

T 305-593-4301

F 305-593-4300

As a company of innovation, GE Security reserves the right to change product specifications without notice.

For the latest product specifications visit GE Security online at [www.GESecurity.com](http://www.GESecurity.com) or contact your GE Sales Representative.