



# SENTROL

## R1078 1" Diameter Steel Door

Magnetic Contacts

Gap distance	Closed loop		
In Steel			
5/8"		R1078	
Color	White	Mohagany brown	Grey
Quantity		10	



R1078-M

**100% TESTED**



## R1078 1" Diameter Steel Door Magnetic Contacts

### Installation Instructions

1. Drill a 1" diameter and 1 1/8" deep hole for the contact. Hole saw arbors are available from Sentrol.
2. Connect the contact leads to the security system loop and test continuity.
3. The 1840 Magnet is designed to be mounted in the top channel of a metal entry/exit door. The magnet can be rotated to accommodate either wide or narrow topchannels.
4. Clean the top channel of the door.
5. Position the magnet opposite the switch in the top of the door channel.
6. Lightly coat the contact and magnet with RTV mounting compound (Sentrol part number 1905) and mount into respective locations.

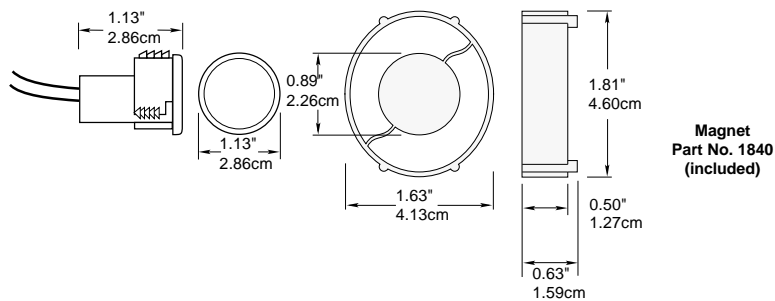

### UL Specifications

\*\*European Union Specifications: 48 VAC/DC Max., 0.5 Amp

Part Number	Loop Type	Electrical Configuration	Gap Distance In Steel*
R1078	Closed	N/O	5/8"

**\*\*FORM A (R1078)**  
**Voltage: 100 VAC/DC Max**  
**Current: 0.5 A Max**  
**Power: 7.5 W Max**

\* Gap Specifications are nominal and may vary  $\pm 20\%$  due to temperature. Gap Specifications are for switch to make. Break distance is approximately 1.1 to 1.5 times make.

### ULC Specifications

**All Contacts: 30 VDC, 50 ma max. Gap Specifications:\***  
**See UL Gap Specifications**



PH 503.692.4052  
**USA & Canada:** 800.547.2556  
**Technical Service:** 800.648.7424 **FaxBack:** 800.483.2495  
[www.sentrol.com](http://www.sentrol.com) [www.interlogixsecurity.com](http://www.interlogixsecurity.com)

©2001 Interlogix, Inc.  
 Interlogix, Caddx, ESL, ITI and Sentrol are  
 trademarks of Interlogix, Inc.