

International SuperBus® 2000 Hardwire Output Module (HOM)

Document Number: 466-1778 Rev. A
August 2000

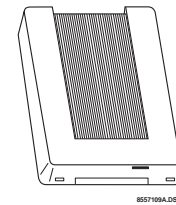

Installation Instructions

About this Document

This document describes how to install and test the ITI® International SuperBus® 2000 Hardwire Output Module (HOM). For HOM programming and operating details, refer to the installation instructions for your security panel.

Note

The panel installation instructions and touchpad displays may refer to HOM relays as outputs or output points. The terms are interchangeable. This document uses the term “relay” to avoid confusion in the wiring diagrams, because the terminals of the HOM are labeled RELAY 1, RELAY 2, etc.

Product Summary

The HOM expands the versatility of compatible panels by adding four programmable outputs. These include both normally open and normally closed dry relay contact outputs.

The HOM also includes one input zone for hardwire sensors. This input is monitored (using an end-of-line resistor [EOL]) and the HOM alerts the panel if there is an open or short circuit.

You can add up to 16 SuperBus 2000 devices to one International Concord™ security panel.

A built-in cover tamper switch provides additional security.

Examples of HOM output uses include the following:

- Turning on a closed-circuit television (CCTV) camera during a burglary alarm.
- Turning on exit lights during a fire alarm.
- Activating backup cellular phones or long-range radios if primary communications are inoperable.

HOM Components

The HOM module comes complete with mounting hardware. Power is provided by the panel.

- Figure 1 shows the main HOM components. Table 1 describes these components

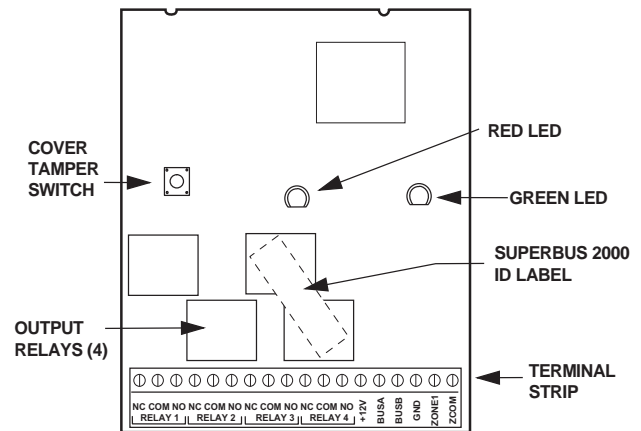

Figure 1. HOM Circuit Board Components

Table 1: HOM Component Descriptions

Component	Function
Red light-emitting diode (LED)	Flashes to indicate normal communication to the panel bus.
Green LED	Indicates power is on.
Output relays	Form C (dry contact) output relays.
Terminal strip	Used for SuperBus 2000 and output wiring connections.
Cover Tamper Switch	Alerts the panel if the HOM cover is removed.
SuperBus 2000 device ID Label	Identifies the unique device ID number assigned to each ITI SuperBus 2000 module

Installation Guidelines

- The International Concord security system supports up to 16 SuperBus 2000 devices.
- Do not exceed the total DC power rating of the panel when using panel power for bus devices and hardwired sensors that require panel power (see the specific panel installation instructions).

Important !
If separate power supplies are necessary to accommodate the HOM modules, safety standards require that each power supply be prominently marked with adequate instructions for removing all power from the unit.

- ❑ Maximum HOM current draw with all relays energized is 180 mA. Each HOM typically draws 25 mA when relays are not energized (idle) and an additional 39 mA per energized relay.
- ❑ Do not exceed the HOM output relay contact ratings (see the specifications section at the end of this document).
- ❑ Use 4-conductor, 22-gauge or larger stranded wire from the HOM to the panel.
- ❑ Use 22-gauge or larger stranded wire from the HOM to the output devices. Refer to the panel installation instructions for wire length limitations.
- ❑ If you are replacing an existing HOM, then you must delete the existing HOM information from panel memory before installing this HOM. See the panel installation instructions for details.

Tools and Supplies Needed

- ❑ Screwdriver
- ❑ 4 self-tapping screws (included)
- ❑ 4 #6 plastic wall anchors (included)
- ❑ 22-gauge or larger stranded hookup wire

Installation

The SuperBus 2000 HOM can be mounted

- ❑ on a wall, or
- ❑ inside a SuperBus Accessory Enclosure, or
- ❑ inside a metal Concord cabinet.

To comply with safety standards, the HOM module, or the cabinet in which the HOM module is mounted, must be secured to the building structure before operation.



CAUTION
To prevent damaging the panel or card, remove AC power from the panel and disconnect the backup battery before installation.

Note
You must be free of all static electricity when handling electronic components. Touch a bare metal surface before touching the circuit board.

Mounting the HOM in a SuperBus Accessory Enclosure

1. Remove AC power from the panel and disconnect the backup battery.
2. Remove the HOM cover and set it aside (Figure 3).
3. Place the back plate inside the cabinet and line up the module mounting holes with the cabinet mounting holes (Figure 2).

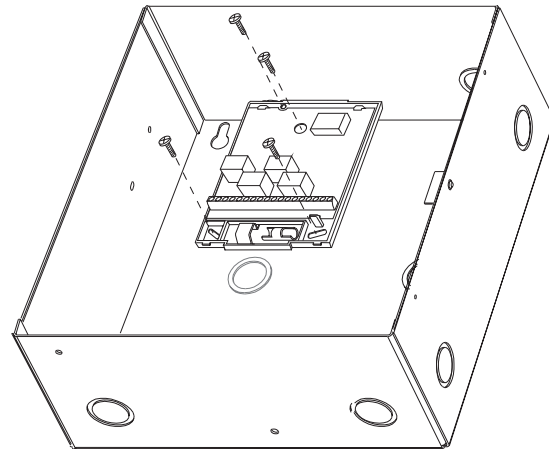

Figure 2. SuperBus Accessory Enclosure (cover not shown)

4. Secure the back plate to the cabinet with four #6-32 self-tapping screws as shown.

Mounting the HOM in a Concord Cabinet

1. Remove AC power from the panel and disconnect the backup battery.
2. Remove and discard the HOM cover (Figure 3).

PRESS DOWN
HERE AND PULL
AWAY FROM BASE

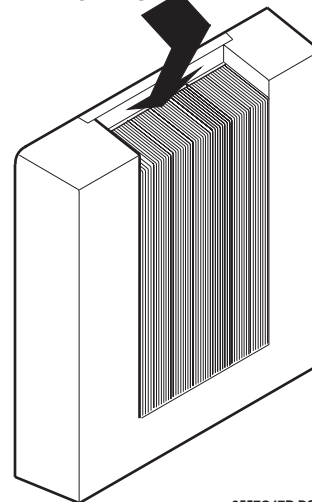

8557G47B.DS4

Figure 3. Removing the Cover

3. Open the panel cabinet cover.
4. Slide the module backplate onto the two module mounting clips located on the top-left, top-center, or top-right corner of the cabinet (Figure 4).

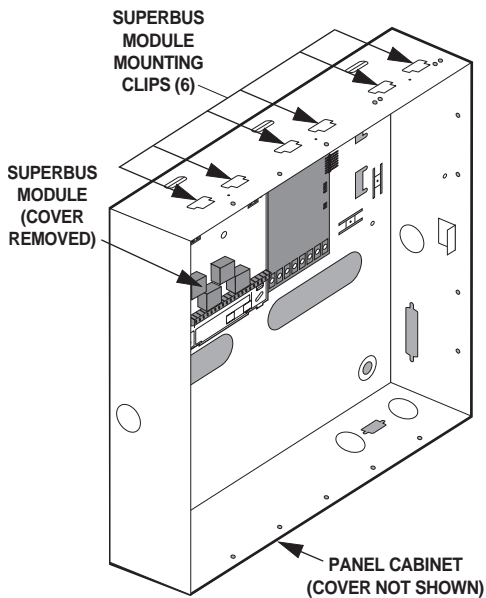

Figure 4. Mounting the Module in a Concord Cabinet

5. Install the supplied standoff between the module backplate and the circuit cards

Mounting the HOM on a Wall

1. Remove AC power from the panel and disconnect the backup battery.
2. Remove the HOM cover and set it aside (Figure 3).
3. Place the back plate on the wall and mark the mounting holes (Figure 5).

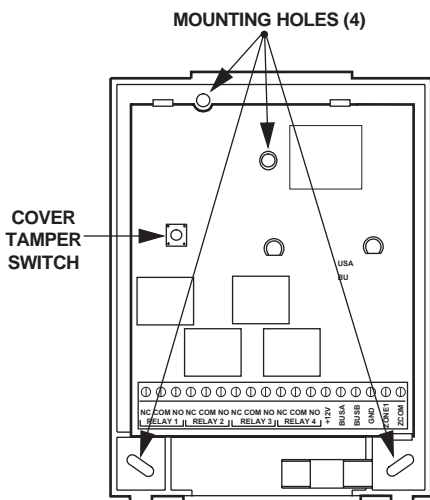

Figure 5. HOM Mounting Holes

4. Drill holes and insert appropriate anchors.
5. Secure the back plate to the wall with panhead screws.

Wiring

This section describes how to wire the HOM to an International Concord security panel and how to wire various devices to the HOM terminals.

To wire the HOM to a panel:

1. Remove AC power from the panel and disconnect the backup battery.
2. Wire the HOM to the panel as shown in Table 2 and Figure 6. For specific SuperBus 2000 wiring details, see the panel installation instructions.

Table 2: HOM to Panel Wiring Guide

HOM Terminals	+12VDC	BUS A	BUS B	GND
International Concord Terminals	1	2	3	4

To wire output devices to the HOM

Wire the HOM supervised hardwire input zone as shown in Figure 6. For specific output device wiring details, see the output device installation instructions. (Example HOM applications and wiring are provided later in this document.)

Module Tamper Detection

If the panel is programmed to detect tampers, the cover tamper switch will cause an alarm when the HOM cover is opened. See the panel installation instructions for details.

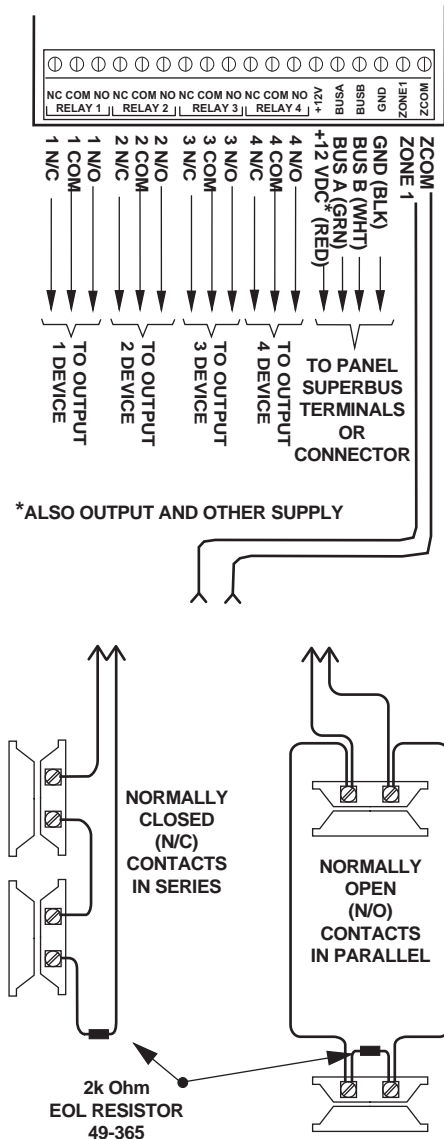

Figure 6. HOM Hardwire Input Zone Wiring

Power-Up and Bus Communication

This section describes how to power up the panel and the HOM and get them communicating with each other.

To power up the panel and the HOM and verify bus communication:

1. Verify that all wiring between the panel, touchpad, and HOM is correct.
2. Connect the panel battery and restore AC power to the panel. Alphanumeric touchpad displays should momentarily indicate:
SCANNING BUS DEVICES

Note
The International Concord security panel scans and

automatically “learns” the device ID number of each bus device when the panel is first powered up. The panel then assigns a unique “address” to each bus device.

3. Enter program mode by pressing **[*]** + **installer code (default = 54321)** + **[0]** + **[0]**. The touchpad should display: *SYSTEM PROGRAMMING*
4. Press **[*]** and the display shows *SECURITY*.
5. Press **[A]** or **[B]** until the display shows *ACCESSORY MODULES*, and then press **[*]**. The display should read: *BUS DEVICES*
6. Press **[*]**. The display shows unit number *00* and its device ID number.
7. Press **[A]** or **[B]** to cycle through all bus device unit numbers until the HOM appears. For example:
UNIT - ID
06 - NNNNNNNN

where 06 is the unit number assigned by the panel and NNNNNNNN is the device ID number on the HOM SuperBus 2000 device ID label.

Note
If the HOM ID does not appear, remove AC power from the panel, disconnect the backup battery, and verify that all wiring is correct.

8. Verify the HOM device ID number by checking it against the SuperBus 2000 device ID label on the HOM circuit board.
9. Use the information in the panel installation instructions to configure the HOM, then press **[*]** repeatedly until the display shows *SYSTEM PROGRAMMING*
10. Press **[A]** or **[B]** until the display shows *EXIT PROGRAMMING READY*
11. Press **[*]** to exit the program mode. The display shows the day, date, and time. The green LED of the HOM should be on to indicate power and the red LED should be flashing to indicate successful communication with the panel.

Note
If the red LED is not flashing, remove AC power from the panel, disconnect the backup battery, and verify that all wiring is correct.

Programming the HOM Input Zone

The HOM input zone must be entered (learned) into the memory of the International Concord security panel. See the panel installation instructions for details.

Programming HOM Outputs

The HOM receives pre-programmed output commands from the panel via the SuperBus 2000 data connection, then energizes the appropriate HOM relay. Relay operation, time delay, and duration are determined by the panel programming. See the panel installation instructions for details.

Application Examples

The following sections provide some examples of typical applications to assist you in configuring the HOM to your specific applications.

CCTV Camera Control Output Example

The following is an example of a CCTV camera controlled by a burglary alarm.

To wire the HOM to a CCTV camera:

1. Remove AC power from the panel and disconnect the backup battery.
2. Wire the HOM module to the panel (see Table 2 and Figure 7).
3. Wire the HOM relay 1 COM and N/O outputs to the camera (or camera multiplexer control) as shown.
4. Restore AC power to the panel and reconnect the backup battery.

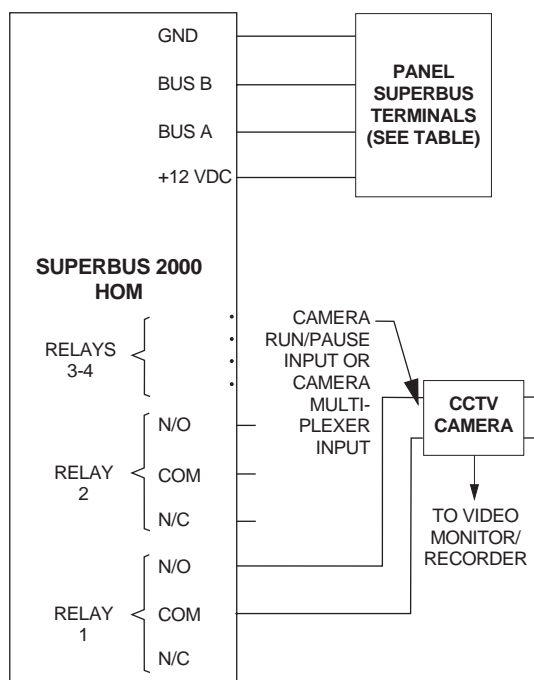

NOTE: DO NOT EXCEED RELAY CONTACT VOLTAGE AND CURRENT RATINGS

Figure 7. Connecting a CCTV Camera to the HOM

5. At the panel, select the desired partition and set HOM relay 1 to trigger on sensor 1 activity (for example, motion detector learned as sensor 1) and have a 3

minute response. This would be HOM configuration code 25701.

LED Indicator Output Example

The following is an example of an LED indicator used to show an arming status condition.

To wire the HOM and LED indicator:

1. Remove AC power from the panel and disconnect the backup battery.
2. Wire the HOM module to the panel (see Table 2 and Figure 8).
3. Wire the LED and the appropriate current limiting resistor in series with the output as shown.
4. Restore AC power to the panel and reconnect the backup battery.

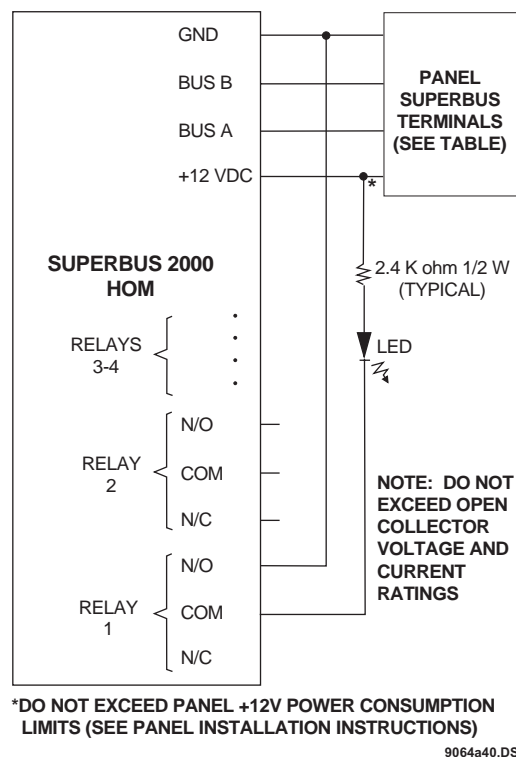

Figure 8. Connecting an LED Indicator to the HOM

5. At the panel, select the desired partition and set HOM relay 1 to trigger on arming levels 2 or 3 with a sustained response. This would be HOM configuration code 00903.

Wireless Overhead Door Control Output Example

The following is an example of a wireless keychain touchpad(s) used to control an overhead door.

Note

This procedure would affect the “star” key of ALL wireless keychain touchpads entered (learned) into the system.

To wire the HOM and overhead door control:

1. Remove AC power from the panel and disconnect the backup battery.
2. Wire the HOM module to the security panel (see Table 2).
3. Wire the HOM Relay 1 COM and N/O outputs in parallel with the overhead door operator control as shown in Figure 9.
4. Restore AC power to the panel and reconnect the backup battery.

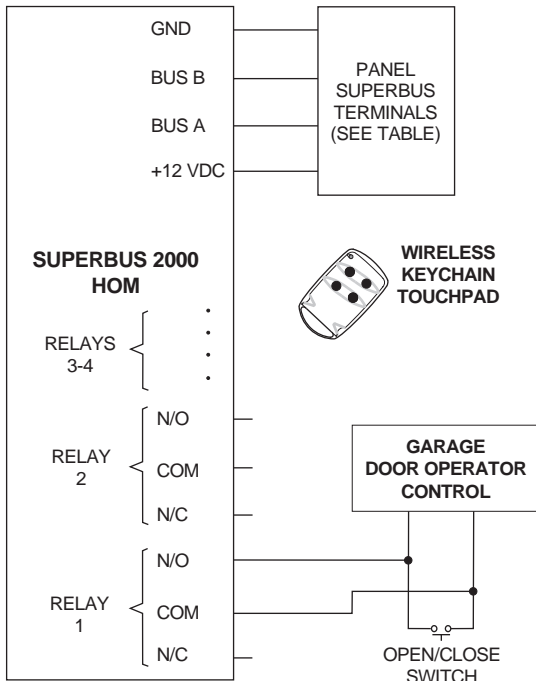

NOTE: DO NOT EXCEED RELAY CONTACT VOLTAGE AND CURRENT RATINGS

9064a41.DSF

Figure 9. Connecting an Overhead Door Operator to the HOM

5. At the panel, select the desired partition and set HOM relay 1 to trigger on a wireless keychain star button and have a momentary response. This would be HOM configuration code 01400.

Long-Range Radio Communications Backup Output Example

The following is an example of a long-range radio used as a communications backup in case of a Failure-To-Communicate (FTC) response from the panel if, for example, the phone lines are inoperable.

To wire the HOM to a long-range radio:

1. Remove AC power from the panel and disconnect the backup battery.
2. Wire the HOM module to the security panel (see Table 2).
3. Wire the HOM Relay 1 COM and N/O outputs to the long-range radio as shown in Figure 10.
4. Restore AC power to the panel and reconnect the backup battery.

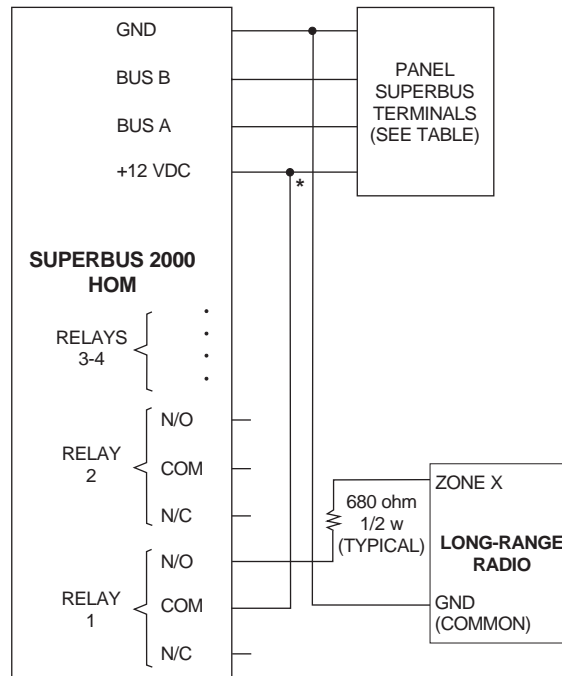

NOTE: DO NOT EXCEED RELAY CONTACT VOLTAGE AND CURRENT RATINGS

***DO NOT EXCEED PANEL +12V POWER CONSUMPTION LIMITS (SEE PANEL INSTALLATION INSTRUCTIONS)**

9064a42.DSF

Figure 10. Connecting a Long-Range Radio to the HOM

5. At the panel, select the desired partition and set HOM relay 1 to trigger on a fail to communicate (FTC) condition and to have a sustained response. This would be HOM configuration code 01203.

4-Wire Smoke Detector (with Power Reset) Example

The following is an example of a 4-wire smoke detector with power reset application.

To wire the HOM and 4-wire smoke detector

1. Remove AC power from the panel and disconnect the backup battery.
2. Wire the HOM module to the security panel SuperBus 2000 terminals as shown in Table 2.
3. Wire the HOM Relay 1 COM and N/C terminals to the smoke detector terminals and Power Supervision Module wires as shown in Figure 11.
4. Wire the smoke detector output terminals to the Power Supervision Module wires and then to any of the unused panel zone inputs and zone input common terminals as shown in Figure 11.
5. Restore AC power to the panel and reconnect the backup battery.
6. At the panel, select the desired partition and set HOM relay 1 to trigger on a smoke power condition and have a momentary response. This would be HOM configuration code 01500.

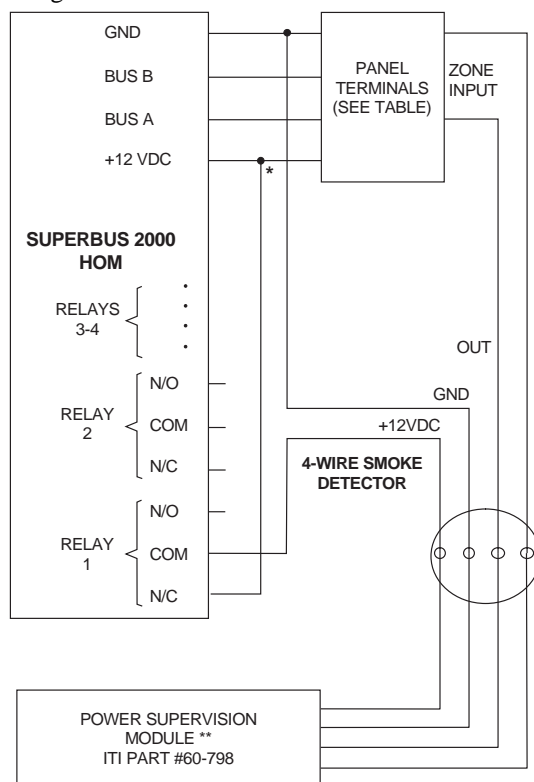

*DO NOT EXCEED PANEL +12V POWER CONSUMPTION LIMITS (SEE PANEL INSTALLATION INSTRUCTIONS)

**LOCATE AT LAST DEVICE. CONTAINS INTERNAL 2.0 K END-OF-LINE RESISTOR BETWEEN GREEN AND WHITE)

NOTE: DO NOT EXCEED RELAY CONTACT VOLTAGE AND CURRENT RATINGS

9064a43.DSF

Figure 11. Connecting a 4-Wire Smoke Detector to the HOM and Concord Security Panel

Testing the HOM Operation

To test the HOM operation, activate each of the programmed system triggering events and check that the desired HOM relays respond.

The HOM status LED (red) should blink regularly when communications to and from the panel (through the SuperBus 2000 data connections) are correct.

Troubleshooting the HOM

Use Table 3 to determine possible solutions to HOM problems.

Table 3: Troubleshooting the HOM

Problem	Solution
The green POWER LED stays off.	<ol style="list-style-type: none"> 1. Check for incorrect wiring connections. 2. Make sure the panel AC power is on and the backup battery is connected. 3. If the LED still remains off, replace the module.
The red BUS LED doesn't flash to indicate communication between the panel and the HOM.	<ol style="list-style-type: none"> 1. Verify that the panel recognizes the module by entering program mode (see specific panel installation instructions). 2. Check for incorrect wiring connections. 3. If the LED still doesn't flash, replace the module.
The red BUS LED blinks but the system does not respond when zones are tripped.	<ol style="list-style-type: none"> 1. Re-initialize the panel by disconnecting and reconnecting panel power. 2. Make sure the zone has been "learned" into panel memory. 3. Verify that the panel recognizes the module by entering program mode (see specific panel <i>Installation Instructions</i>). 4. Remove zones and try installing the module without the zones. 5. Replace the module.
One relay never activates.	<ol style="list-style-type: none"> 1. Check panel/HOM programming. 2. Check that the point (particular HOM output) programmed trigger event actually occurs. 3. Check output-to-output device wiring.
Relay(s) activate only momentarily. OR Relay(s) activate randomly.	<ol style="list-style-type: none"> 1. Check panel/programming (particular HOM output) uses correct response configuration. 2. Check SuperBus 2000 wire routing and length.

Table 3: Troubleshooting the HOM (Continued)

Problem	Solution
One relay stays activated.	<ol style="list-style-type: none"> 1. Check if the point is programmed for a 3 minute "on" time and if the triggering event for the point is repeatedly "resetting" the 3 minute timer. 2. Relay may have failed or been overloaded. Reprogram to use a different (unused) relay or replace module.

Replacing the HOM Cover

To replace the HOM cover on wall mount installations:

1. Insert the two tabs at the bottom of the module back plate into the slots of the cover.
2. Swing the cover up and press onto the back plate until it clicks into place.

Note
On in-cabinet mounting installations the HOM module cover is not used and may be discarded.

Specifications

- Compatibility:** International Concord security panels.
- Power Requirements:** 12 VDC, 25 mA typical (idle), plus 39 mA per energized relay (180 mA maximum with all relays energized). Power supplied from the panel through the SuperBus 2000 connections.
- Input:** One supervised hardwire input zone
- Outputs:** Four panel programmable, "Form-C" relay contacts (COMMON, N/C, N/O). Relay contacts rated 5.0 A at 30 VDC or 70 VAC
- Storage Temperature:** -30° to 140° F (-34° to 60° C)
- Operating Temperature Range:** 32° to 140° F (0° to 60° C).
- Dimensions:** 5.25" (133.4mm) L x 4.125" (104.8mm) W x 1.0" (25.4mm) D
- Case:** Belgian gray ABS plastic

Notices



This Intruder Alarm System Accessory (Security Grade 2, Environmental Class II) has been manufactured to comply with the following European directives:

[i] EMC Directive 89/336/EEC amending directive 92/31/EEC & 93/68 EEC as per

EN 50081: 1992
EN 50130-04: 1995

[ii] Low Voltage Directive (Safety) 73/23/EEC as per

IEC 60950: 1999-04

Changes or modifications not expressly approved by Interactive Technologies, Inc. can void the user's authority to operate the equipment.

©2000, Interactive Technologies, Inc., an Interlogix company. Interlogix is a trademark of Interlogix, Inc. ITI and SuperBus are registered trademarks of Interactive Technologies, Inc. Concord is a trademark of Interactive Technologies, Inc.



Interactive Technologies, Inc.
2266 Second Street North
North Saint Paul, MN, USA 55109-2900
T: 651/777-2690
F: 651/779-4890
1-800-777-1415

Security
Automation
Fire Protection
Access Control

www.ittechnologies.com

an **interlogix** company.