

INSTALLATION

AND

USER'S

MANUAL

CS-4000 CENTRAL STATION RECEIVER



Interactive Technologies, Inc.

CS-4000 CENTRAL STATION RECEIVER

Printed
August 1992

Interactive Technologies, Inc.
2266 North Second Street
North St. Paul, MN 55109
(612) 777-2690
(800) 777-1415

ITI 1992 - Part # 46-056
Issue Date 7/24/91

U.L. Statements

UL1610 - Central Station Burglar Alarm

1. Either the Yuasa Model NP38-12, 12V, 38Ahr or the Panasonic Model LCL12V65P, 12V, 65AHR battery shall be employed. The ITI p/n 49-134 battery cable shall be used.

NFPA71/UL864 - Control Units for Fire-Protective Signalling Systems

1. The Model CS4000 Annunciator (60-417) shall be employed. For installation requirements, refer to the CS-4000 Annunciator Users and Installation Guide, p/n 46-358.
2. Both the CS-4000 DACR and Annunciator shall be mounted within the same 19 inch rack. The 19 inch rack shall be a listed Control Unit, System Accessory (UOXX) manufactured by Atlas Soundalier, p/n UWA-100 or UWA-200.
3. Both the DACR and annunciator shall be connected to a Panasonic Model LCL12V65P, 12V, 65Ahr battery. The ITI p/n 49-349 battery cable shall be used to connect the DACR and Annunciator to the battery.
4. A minimum of two phone lines (numbers) shall be employed.

TABLE OF CONTENTS

<i>SECTION 1</i>	<i>INTRODUCTION</i>
1.1 Outline of Manual	1
1.2 Software/Hardware Features	2
1.3 Front/Back View of Receiver	4,5
<i>SECTION 2</i>	<i>CS-4000 INITIAL SETUP</i>
2.1 Connections and Power Up (Setup Checklist)	6
2.2 Set Operator Password	10
2.3 Select and Set Receiver Options	13
2.4 Commands that Affect the Receiver	17
2.5 Receiver Troubleshooting and Self Tests	20
<i>SECTION 3</i>	<i>OPERATING THE CS-4000</i>
3.1 Receiver Controls and Hardware	24
3.2 Keyboard Functions	27
3.3 HELP Feature	29
3.4 Reading the CRT Display	30
3.5 Use of the Password Command	33
<i>SECTION 4</i>	<i>PROGRAMMING A CPU</i>
4.1 Introduction	36
4.2 Interactive Commands that Affect a CPU	40
4.3 The TRAP Command	46
4.4 How to Program an Unprogrammed CPU	49
4.5 Reprogramming an Existing Phone/Account Number	54
4.6 The GROUP Command--	
SX-V Group Nos., Letter Codes	58
SX-IVB Group Nos., Letter Codes	60
SX-III/IVA Group Nos., Letter Codes	61
Explanation of GROUP Command	63
Advanced Group Changes	67
Examples of Group Changes	70
4.7 SX-V Only Commands	73

SECTION 5**CENTRAL STATION MESSAGES**

5.1 Central Station Messages During An Alarm	78
5.2 Central Station Messages During the Zone Command	83
5.3 Central Station Fault and Status Messages	87
5.4 Central Station Error Messages	89
5.5 Communication Messages	90
5.6 Central Station Messages During Interactive Programming	91
5.7 Examples of Central Station Reports	92

SECTION 6 INTERFACING PERIPHERAL DEVICES TO THE CS-4000

6.1 Overview	93
6.2 Interfacing a Computer to the CS-4000	95
6.3 Interfacing a Printer to the CS-4000	102
6.4 Interfacing a Terminal to the CS-4000	106
6.5 Custom Interface Formatting	108

SECTION 7**NON ITI FORMAT PANELS**

7.1 The CareTaker™	111
7.2 Non-ITI Formats	113

APPENDIX A	ITI GENERIC COMPUTER OUTPUT FORMAT
APPENDIX B	RS-232 PORT FORMAT AND SIGNAL EXPLANATION
APPENDIX C	MISCELLANEOUS WARNINGS AND NOTICES
APPENDIX D	CPU LEVELS OF OPERATION
APPENDIX E	MISCELLANEOUS WARNINGS AND NOTICES
APPENDIX F	UNDERWRITERS LABORATORIES INSTALLATIONS
APPENDIX G	COMMANDER PROGRAMMING COMMANDS
APPENDIX H	ITI COMP FORMAT
APPENDIX I	RF COMMANDER PROGRAMMING COMMANDS
APPENDIX J	SOFTWARE RELEASE NOTES VER. 3.2 01/01/91
APPENDIX K	SOFTWARE RELEASE NOTES VER. 3.2 06/06/90
APPENDIX L	SOFTWARE RELEASE NOTES VER. 3.2 10/15/89
APPENDIX M	SOFTWARE RELEASE VER. 4.0 6/15/92

PARTS LIST

The following is supplied with each CS-4000--

- 1 - CS-4000 ITI Interactive Central Station
- 1 - CS-4000 Manual
- 1 - Cable for Radio Shack printer Model DMP 106
- 1 - Open ended cable for hooking up a computer
- 1 - Backup battery cable
- 1 - External siren output cable
- 1 - SX-IVB Installation Manual
- 1 - SX-V Installation Manual
- 1 - AC power cord

SECTION 1

INTRODUCTION

1.1 PREFACE

The ITI CS-4000 Receiver is capable of monitoring all ITI systems, including the new SX-V, CareTaker[®], and Commander[™] systems as well as most other popular communicator formats from other alarm panels.

NOTE: See "Section 7.2 - NON ITI FORMATS" for a complete listing of panels that have been tested and found to be compatible to date with the CS-4000.

In addition to being a receiver, the ITI CS-4000 Receiver is "Interactive." This means that the CS-4000 and an ITI CPU can communicate with each other. Many programming changes, such as delay times and customer access codes, which typically needed to be done by the technician at the installation site, can now be programmed or changed with the CS-4000. ITI was the first company to introduce interactive downloading capabilities to the alarm industry.

The ITI CS-4000 Receiver is "User Friendly", meaning that all commands and printouts are in simple English. There is also an on-line users guide, the HELP command, that provides the operator with menus of all the different commands and functions as well as step-by-step instructions and examples of how to use a specific feature or command.

This manual is intended for use with the ITI CS-4000 Interactive Central Station Receiver. It is divided into sections covering the specifics of set-up, operations and programming. We recommend that you thoroughly review each section of the manual before attempting to perform any of the programming commands or operations.

This manual has been designed to provide you with quick reference to as much information as possible in a readable format. Please read each section before attempting to perform any of the commands or operations in that section.

FCC Registration Number: B4Z 8NW-16726-DT-N

Ringer Equivalence Number: 2.3B

Load Number: 100

The CS-4000 is not approved for use in the State of Texas for fire alarm applications governed by Article 5.43-2 of the Texas Insurance Code. Please contact ITI Technical Service for further assistance regarding this application.

NOTE - UL INSTALLATIONS - Failure to install and program the system as indicated for applicable Underwriters Laboratories installation is a violation of the Listing Mark.

1.2 SOFTWARE/HARDWARE DIFFERENCES

The CS-4000 has many features that are different from our former central station. These include:

HARDWARE DIFFERENCES

1. The CS-4000 uses 12 volt DC battery backup, not 24 volt DC! U.L. recommends the Yuasa NP38-12.
2. There are separate standard (6 position) telephone jacks for **both** the programming telephone and the incoming phone for Line 1. You do not need an RJ-31X jack for the Programming (Line 1) phone connection.
3. The CS-4000 has 3 RS-232 input/output serial connector ports. These 3 ports are independent of each other and can all be used simultaneously.
4. The CS-4000 does not have a built-in printer. You can use most of the popular serial printers available. We have different printer output formats via the RS-232 ports. (UL requires that the Tandy Inc. Model DMP-106 printer shall be used.)
5. The CS-4000 has a CRT display that shows many forms of information.
6. The CS-4000 has a built-in CPU programming jack.
7. The Keyboard is a personal computer-style keyboard. (UL requires that the Maxiswitch Inc. Part Number 2186002A keyboard be used.)
8. The CS-4000 has been designed for rack mounting or use the flip down legs and place on a table.
9. The CS-4000 is equipped with a built in lithium battery which holds the RAM memory should there be a total power loss. This feature allows the CS-4000 to power up to previous Receiver Options and to retain screen memory.

SOFTWARE DIFFERENCES

1. The HELP feature can answer questions you have regarding any command. (Refer to the section on the Help Feature).
2. The PASSWORD configuration has been changed. You have the option of setting up 20 operators and assigning each a number, a password, and a separate privilege level. (Refer to section on Use of the Passwords Command).
3. When a command that affects a CPU program is entered, the Receiver displays both the previous information in the memory of the CPU and the new information that you have just entered into the CPU memory.
4. All commands used for the SX-IVB will work with the SX-V. However the SX-V has additional commands that will not work with either the SX-III/SX-IV or the SX-IVB.

5. We refer to PORTS as ZONES in this manual. However, PORT and ZONE both mean the same thing.
6. The PHONE command replaces ONLINE, and should be used from now on. ONLINE is an obsolete command.
7. When a command is entered, it is displayed in the command window, then on the Scroll after the enter key is pressed.
8. Letter codes are now referred to as "Attribute Codes"
9. The Receiver will display the date and time every hour on the hour in the Scroll of Events Window. Date and time are continuously displayed in the Date and Time Windows.
10. When a command such as ACCOUNT or PHONE is entered, the Receiver will display the current data in the CPU followed by the data you have just entered.

Example: You are programming an ACCOUNT number of IT-100 in an unprogrammed CPU:

Type: *ACCOUNT IT-100* <enter>

Reply: Account = 00-000 (This is what the account number was.)

Account = IT-100 (This is the new account number.)

CS-4000 FRONT VIEW

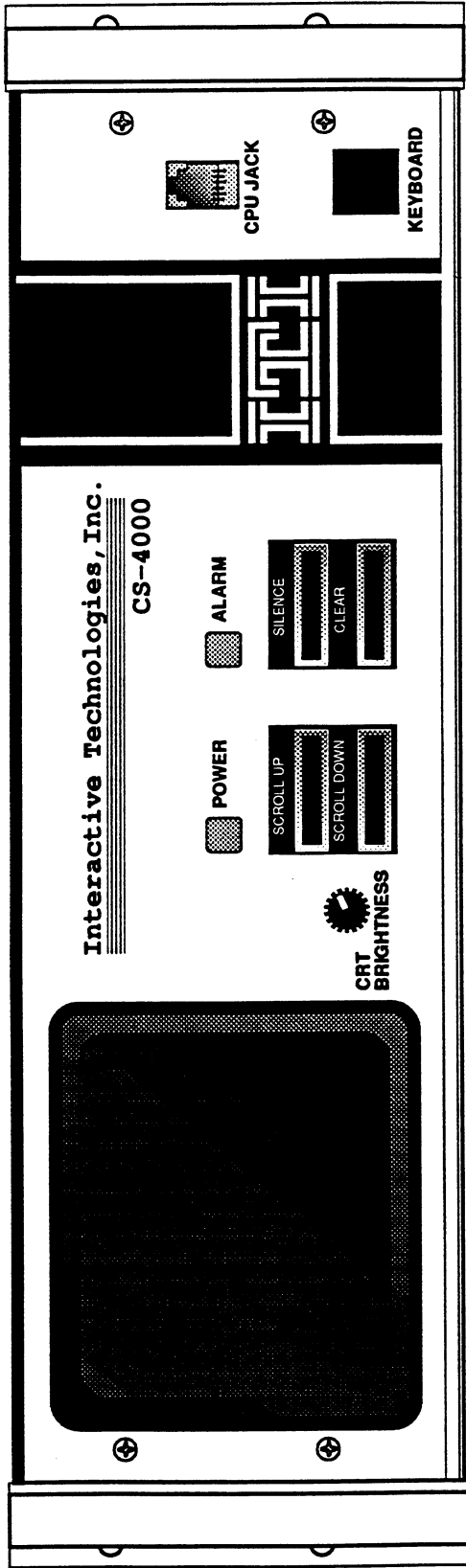

CS-4000 CRT SCREEN

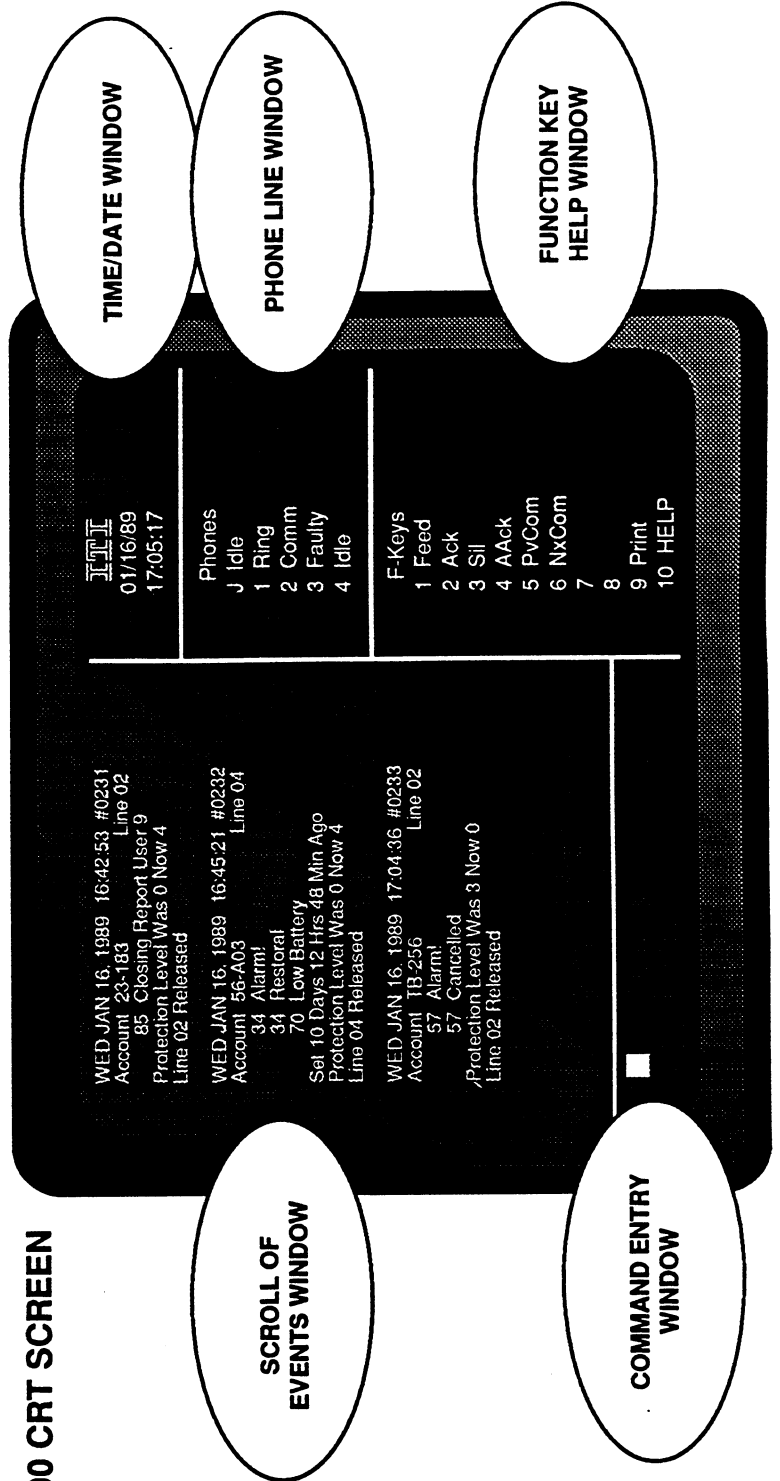

CS-4000 BACK VIEW

MONITORING AND PROGRAMMING PHONE INPUTS

POWER FUSES

RS-232 JACKS TO INTERFACE TO A COMPUTER, PRINTER OR TERMINAL

FAULT RESET BUTTON

EXTERNAL SIREN ALERT CONNECTION

SWITCHABLE LINE VOLTAGE CARD FOR 100/120 V or 220/240 V OPERATION

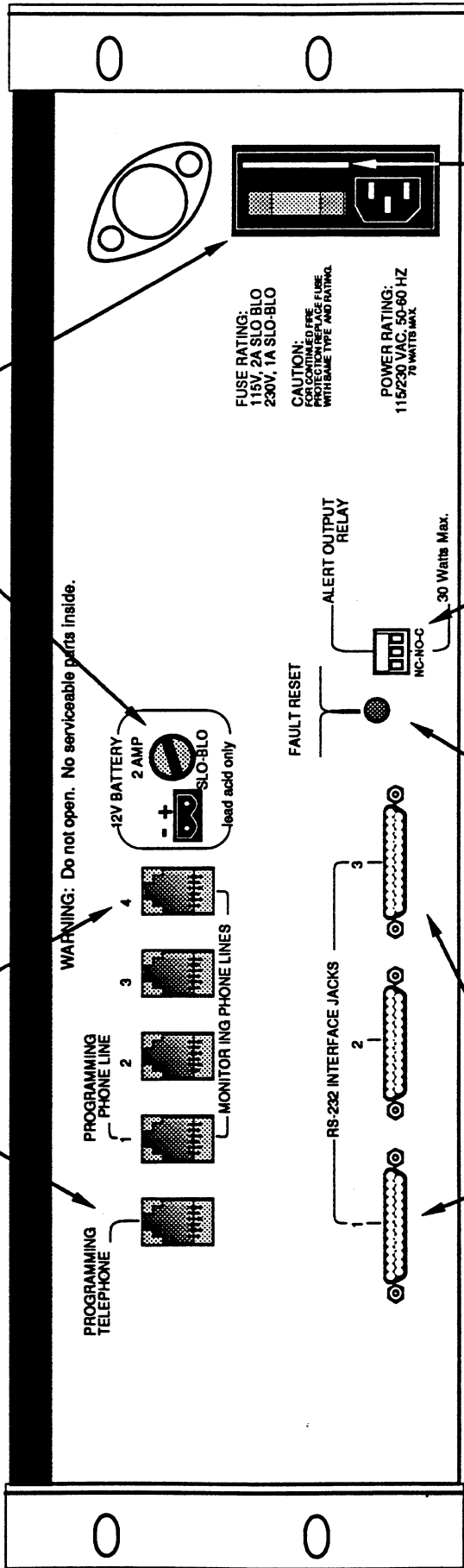

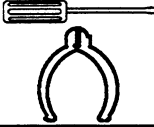

SECTION 2**CS-4000 INITIAL SETUP****2.1 CONNECTIONS AND POWER UP**

The following checklist outlines what will be covered through this section.

√ SETUP CHECKLIST

- √ Connect Keyboard to Receiver
- √ Plug in A/C Cord
 - Type: *CHANNEL 1 OFF*
 - Type: *PASSWORD PERMANENT* <enter>
- √ Connect Backup Battery
- √ Connect Phone Lines
- √ Connect Programming Phone
- √ Set Receiver Date and Time
- √ Set Receiver Options

ALERT	CTIME	LINE FAULTS
OPERATOR(S)	PASSWORDS	PNUMS
POWER FAULTS	PTIME	QUIET
RING	SILENT	STAMP
	TEST	
- √ Construct a Cable for Serial Printer
 - Connect Printer Cable, Set Switches (if needed)
 - Configure Channel 1 Format for the Printer
 - Turn Channel 1 ON
- √ Construct a Cable for Computer
 - Connect Computer Cable
 - Configure Channel 2 Format for the Computer
 - Turn Channel 2 ON
- √ Type: *MSTATUS* <enter>
It is important that the Central Station Manager have a complete MSTATUS list in case of trouble.
- √ Type: *PASSWORD OFF* <enter>

KEYBOARD CONNECTION

The keyboard connects to the circular jack on the lower right corner of the front of the Receiver (refer to the diagram on page 5). Be sure to keep the notch of the keyboard plug to the top!

AC POWER CONNECTION

Connect the AC power cord to the back of the Receiver. (Refer to the diagram on page 5). Plug the AC power cord into a grounded, non-switched source of 115 volts 60 Hz AC Power before connecting the battery. (Upon power up the CS-4000 will appear "dead" for about 10 seconds while the Receiver performs a self-test.)

NOTE: Use of a TOPAZ Line Noise Suppressing Ultra-Isolator, TOPAZ part number 91091-12, or equivalent is recommended.

BACK-UP BATTERY CONNECTION

For Standby Power connect a backup battery. A two-wire cord with connector is supplied with the Receiver for connecting the Backup Battery. The Backup Battery connector is in the parts package. It plugs into the receptacle on the back of the Receiver labelled " BATTERY + - ". (Refer to the diagram on page 5.) The Back-up Battery must be lead-acid or gel cell as the built-in float charger is designed for a lead-acid chemical system. The Receiver requires a 12 Volt DC deep discharge battery--YUASA NP38-12 (38 amp hour) gel cell or equivalent is recommended for U.L. This will give approximately 24 hours of battery backup. Small gel cell batteries (3 amp hour minimum) may be used if an emergency power generator is available. The estimated battery life is 5 years.

If you power up the Receiver without battery back-up the Receiver will reply:

Battery (Backup Test) ON
Ready
Low Backup Battery

← Bold type indicates highlighted words.
on the CRT screen.

If you are not using a backup battery turn the battery Fault OFF by:

Type: *FAULT BATTERY OFF* <enter>

WARNING! The CS-4000 Central Station uses 12 Volt DC not 24 Volt DC as our former Central Station did.

PRINTER CONNECTION

NOTE: The CS-4000 is compatible with serial printers only, not parallel printers..

If you are using a printer, connect it to Channel 1 (RS-232 Port 1) using a cable configured to meet the requirements of the printer and the Receiver. The procedures for interfacing a printer to the Receiver are explained in detail in the section **INTERFACING A PRINTER TO THE CS-4000**. The Receiver expects a printer to be connected to **CHANNEL 1** and will print the following error message every few seconds until a printer is connected or the function turned OFF:

ERROR: DSR Timeout channel = 1

Type: *CHANNEL 1 OFF* <enter> to turn this command OFF *after* power up until you are ready to connect a printer to the Receiver.

EXTERNAL ALERT RELAY CONNECTION

The Receiver is equipped with a N/O, N/C Form C Relay for connecting an external sounder. A 3-wire cord with connector is supplied for use with this relay output. A power supply is needed to power the external sounder.

PHONE LINE CONNECTION(S)

The CS-4000 has four phone jacks for receiving calls. Phone lines connect to the Receiver by a standard (6 position) telephone cord such as those used with an RJ-11C phone jack. See diagram on page 9.

Line 1 is used for the programming line connection. (Line 1 will also receive calls if needed.)

The programming phone line connects to the Line 1 jack using a male-to-male 6 position standard telephone cord and an RJ-11C jack. (Refer to the diagram on page 9).

The programming telephone plugs into the Programming Telephone Jack on the back of the Receiver. You do not need to use an RJ-31X jack since the Receiver has internal line seizure built in, and the telephone is directly connected to the Receiver.

Lines 2, 3 and 4 will be used to receive calls from subscribers control panels.

For Example:

- Line 2 - receives calls from systems which dial a local number.
- Line 3 - receives calls from systems which dial an in-state WATS number.
- Line 4- receives calls from systems which dial national or regional WATS number.

Lines 2, 3 and 4 accept a standard 6-position cord used with an RJ-11C jack. To connect these lines, use an RJ-11C jack connected to incoming Tip and Ring and a straight through male-to-male 6-position telephone cord as shown on the drawing for the Line 2 connection.

DIAGRAM OF TELEPHONE CONNECTIONS

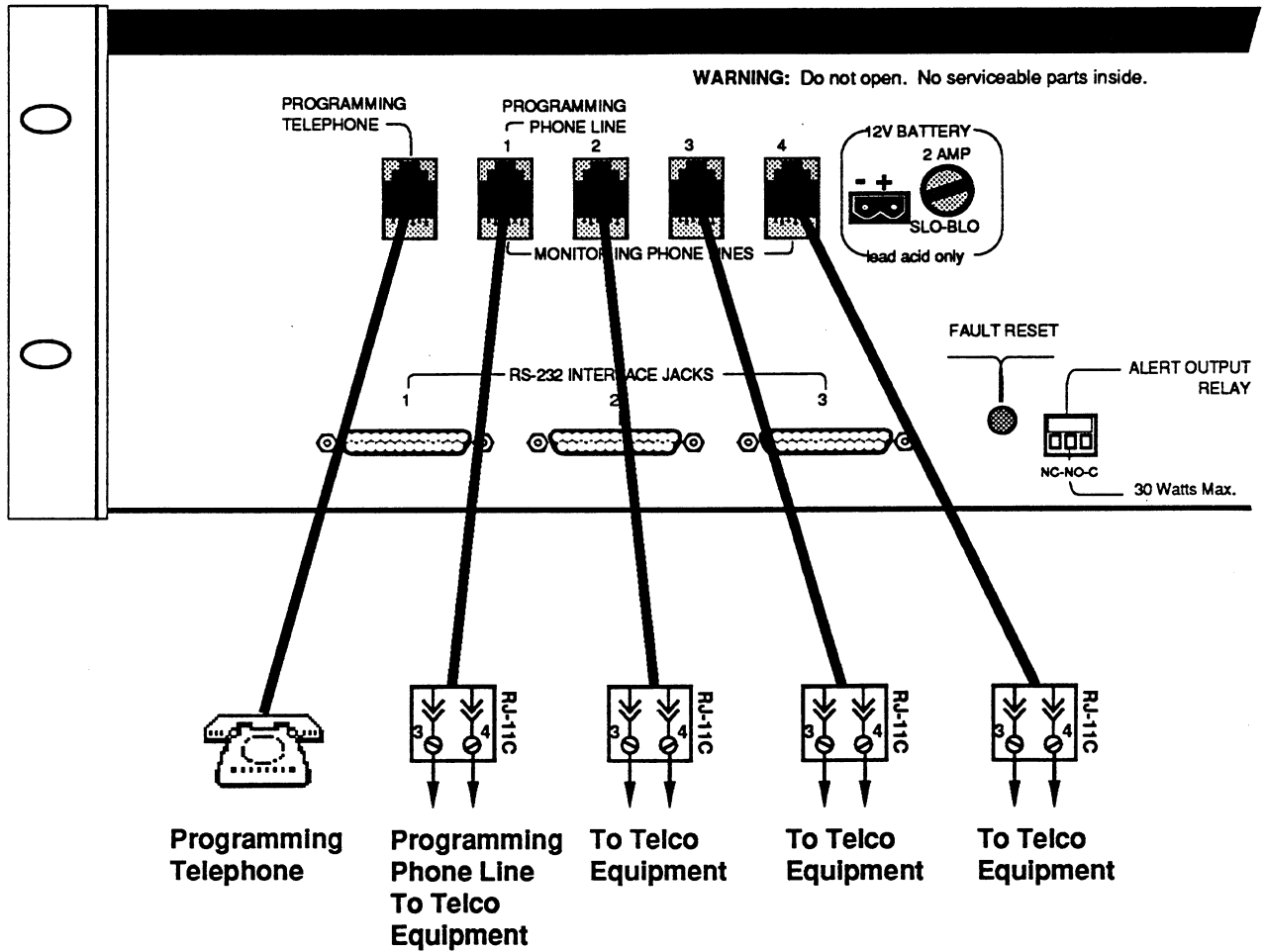

2.2 SET OPERATOR PASSWORDS

PRELIMINARY CONSIDERATIONS

The CS-4000 has four levels of password "privileges": No Level, Low Level, Hi Level and Master Level. The CS-4000 can recognize up to 20 operators. This means that each operator has their own number, privilege level and password, as set up by the MASTER (Operator 1). This gives the MASTER the option of choosing either Hi or Low Level passwords for each operator. (Refer to the Section 3.5 USE OF THE PASSWORD COMMAND for detailed explanation of the passwords.) The MASTER is always Operator #1.

With the Privilege Level set to MASTER all Low and Hi level commands may be performed. When you first power up the CS-4000 the password is set to MASTER for 10 minutes to let the operator perform the commands which set up Operator Password, Date/Time, and Receiver Options. After 10 minutes, the Receiver removes the MASTER password privilege, and from that point on each operator will have to enter their own password to perform commands. If 10 minutes is not sufficient time to set up the Receiver, the password may be set to Permanent. *By setting the password to Permanent operators may perform any and all commands.* (UL requires that at least two password levels be employed with each installation.)

NOTE: You should not leave the Password Permanent because there are no privilege levels, and anyone can use any command at the Receiver.

USE OF THE PASSWORD COMMAND

The CS-4000 Password command is different than ITI's old Central Station. The procedure for using the Password is as follows:

On a CS-4000 the default Password is ABCDE. Entering a Password of ABCDE will set the MASTER Password Privilege level. Upon power-up the Receiver will automatically be set to the Master privilege level for 10 minutes.

Example:

Type: *PASSWORD 1 %****** <enter>
 Reply: Privilege Level Set to Master

NOTE: When you enter your Password, the display will hide it and show asterisks in place of the characters. All passwords must be preceded by a % sign.

The Receiver will reply telling you that you are privileged to the Master Level. Whenever you enter a Password correctly, you will be privileged at that level for 10 minutes.

To make your Password permanent, you would first enter your Password followed by another command to set Password Permanent.

2.3 SELECT AND SET RECEIVER OPTIONS

The CS-4000 has many options which effect Receiver operation. All of the options power-up to a default setting. It is important to consider each option and decide how to set it.

There are three commands which allow the operator to view the Receiver Options to three different extents:

1. The **FAULT** command causes the Receiver to display the current Power, Line Fault, and Ring conditions.

Type: *FAULT* <enter>

2. The **STATUS** command causes the receiver to give the conditions of additional options (Alert, Battery, Channels 1, 2, 3, Ctime, Demomode, Ptime, Quiet, Silent, Stamp, Test, Privilege Level) plus the **FAULT** information. A printout of the **STATUS** listing should be kept near the receiver for reference.

Type: *STATUS* <enter>

NOTE: It is important to keep a **STATUS** list near the Receiver in the event of trouble. When this occurs Receiver Options may be set to power-up default settings.

3. The **MSTATUS** command causes the Receiver to display the information from the **STATUS** command but also includes a full **CHANNEL** option listing, **PNUM** table, **TRAP** table, **OTHER** options and the **OPERATOR** table. This is a **HI** Level command. This listing would be kept by the Central Station Manager. It contains information that can only be accessed by privileged commands.

Type: *MSTATUS* <enter>

SET RECEIVER DATE AND TIME

To set the date:

Type: *CSDATE mm/dd/yy* <enter>
(with "mm" = month, "dd" = day and "yy" = year).

To set the time:

Type: *CSTIME hh:mm* <enter>
(with "hh" = hour and "mm" = minutes in military time; seconds are automatically set to "00").

NOTE: The Receiver will display date and time every hour on the hour in the Scroll of Events window. Date and time are also continuously displayed in the Date and Time Window on the top right hand corner of the screen.

RECEIVER OPTIONS

The Receiver Options allow you to tailor the CS-4000 to your requirements. The Receiver options are:

Power Faults: The Power Faults monitor the condition of the AC Power, Backup Battery and Battery Fuse. LEAVE THESE FAULTS ON so you will be alerted to trouble.

Line Faults: The Line Fault monitors the condition of each phone line you are using. If you set the line fault to ON for a phone line, the Receiver will monitor the condition of that phone line and alert you if trouble has occurred.

Ring Feature: The Ring Feature allows you to receive calls on a phone line. LEAVE THIS FEATURE ON.

Test Feature: Determines whether or not a subscriber's sirens will sound at the completion of a successful Phone Test (ITI format only).

Ptime Feature: Determines whether or not the Receiver will display the last time the subscriber used the access (arming) code (ITI format only).

Quiet Feature: Silences the Receiver's annunciator to sound only on alarm or cancellation calls.

Alert Options: The Alert options select certain types of calls from CPU's to sound the Receiver's annunciators. These options will be discussed later.

Silent Feature: This feature will silence the built-in annunciator for all calls, but will sound in the event of soft-or-hardware trouble conditions.

Ctime feature: (SX-V only) Determines whether or not the CPU's clock will be displayed or updated at the end of a call (report).

Pnum feature: Allows you to store phone numbers in the Receiver's memory that you use to program a customer's CPU (ITI format only).

HOW TO SET THE RECEIVER OPTIONS

SET POWER FAULTS--Backup battery, AC Power, Battery fuse

These faults power up ON so the Receiver will test each condition every 1/2 hour, with the exception of the battery test which is performed by the BATTERY command. The Receiver will sound the alert if the condition is not good. If you wish to change the power faults, do so now.

Type: <i>FAULT BATTERY ON/OFF</i> <enter>	<i>IT IS SUGGESTED TO</i>
Type: <i>FAULT A/C ON/OFF</i> <enter>	<i>LEAVE THESE</i>
Type: <i>FAULT FUSE ON/OFF</i> <enter>	<i>FEATURES ON!</i>

(UL requires that these fault features be in the "ON" position.)

SET THE LINE FAULT

This FAULT monitors the voltage on a phone line every half hour. The Receiver displays the current conditions of the four telephone lines in the Phone Window located in the right center of the CRT. When there is no voltage present the line will show FAULTY; if voltage is present the line will show IDLE. The line will show GOOD if the voltage is present when doing a Status report. If you are not using a line you should turn the FAULT OFF for that line number.

Type: *FAULT* <enter> to check the STATUS of the FAULT conditions
 Type: *FAULT n ON* <enter> to turn the FAULT ON
 Type: *FAULT n OFF* <enter> to turn the FAULT OFF (With "n" being line 1,2,3 or 4)

SET RING FEATURE

The RING feature determines whether or not the Receiver will answer an incoming call. When RING is ON the Receiver will answer a call. All lines power up with RING ON. LEAVE THE RING FEATURE ON IN MOST CASES.

If a RING feature is turned OFF this will be displayed in the Phone Window as RNGOFF.

Type: *RING n ON* <enter> to turn the RING ON for line "n"
 Type: *RING n OFF* <enter> to turn the RING OFF for line "n"

NOTE: If Line 1 is used for programming only, and it is not used for receiving calls, it may be set to RING 1 OFF so the installer may call the operator on the programming line without the Receiver answering the call.

SET THE TEST FEATURE

The TEST feature powers-up ON: This means that the CS-4000 will cause the sirens to sound at the subscriber's home or business to automatically signal successful completion of a Phone Test from an ITI control panel. The annunciators make each of the three alarm sounds (auxiliary, burglary and fire) for two seconds. The exterior siren will sound on the fire and burglary parts of the test.

With the TEST feature OFF, acknowledgement of a successful test would be by a phone call from the Central Station operator to the subscriber. The Receiver will beep when a phone test calls in with TEST OFF mode initiated. The Receiver will not annunciate for phone tests with TEST ON.

Type: *TEST ON* <enter> to turn TEST ON
 Type: *TEST OFF* <enter> to turn TEST OFF

SET THE PTIME FEATURE

The PTIME feature is initialized OFF. When ON, PTIME will have the ITI CPU tell the Receiver to display the last time the access code was used on an alarm call only!.

Type: *PTIME ON* <enter> to turn PTIME ON.

Type: *PTIME OFF* <enter> to turn PTIME OFF.

SET THE PNUM PHONE NUMBERS

The PNUM feature allows you to store phone numbers used when programming a CPU into the Receiver's Memory. This makes programming a phone number in a CPU much easier. (The numbers shown below are examples only.) Up to 10 numbers may be stored (PNUM A through PNUM J). Maximum length of phone number is 14 digits.

Type: *PNUM A 555-1234* <enter> for your local line

Type: *PNUM B 1-612-555-1234* <enter> for your state wide line

Type: *PNUM C 1-800-555-1234* <enter> for your WATS line

SET THE QUIET FEATURE

The QUIET feature is initialized OFF - all incoming calls will sound the annunciator. When QUIET is ON the annunciator sounds *only* for alarms or cancellations. It will not sound for alarm-cancel combinations for trouble reports (supervisory, low battery, etc.). For additional annunciation options refer to the Alert features below.

Type: *QUIET ON/OFF* <enter> to set the QUIET feature.

(UL requires that the quiet feature be programmed "OFF".)

SET THE ALERT FEATURES



The ALERT options allow additional annunciation when an Alert feature is turned ON. These options are initialized OFF.

OPTION	DESCRIPTION
Alarm/Can	Alert sounds when there is an ALARM report and a CANCELLED report
Opening	Alert sounds on opening reports
Closing	Alert sounds on closing reports
Zone 90	Alert sounds on report of Zone 90(AC power loss)

Type: *ALERT option ON* <enter> to turn an ALERT option ON.

Type: *ALERT option OFF* <enter> to turn an ALERT option OFF.

("option" is a feature from the ALERT list)

(UL requires that the alert feature be set "ON" for all options listed above.)

SET THE ALERT INTERACTIVE FEATURE

The ALERT INTERACTIVE feature controls the annunciator which beeps every 30 seconds when you are "Interactive" with a CPU. The "Interactive" feature is initialized ON. It is suggested to leave this feature ON.

Type: *ALERT INTERACTIVE ON/OFF* <enter>

SET THE ALERT WAITING FEATURE

The ALERT WAITING feature shows the number of reports waiting "to be acknowledged" if that number is greater than one. It is independent of ALERT features, and not affected by the QUIET Command. This is initialized OFF.

Type: *ALERT WAITING ON/OFF* <enter>

SET THE SILENT FEATURE

The silent feature is initialized OFF. When the SILENT feature is turned ON, the annunciator is *silenced for all calls*. The annunciator will sound only on hardware or Receiver faults. (The annunciator also sounds every 30 seconds while Interactive with a CPU unless Alert Interactive is OFF.) This feature is typically used when monitoring supervisory Low Battery Reports only or used in connection with a computer system.

Type: *SILENT ON* <enter> to turn silence feature ON

Type: *SILENT OFF* <enter> to turn silence feature OFF

(UL requires that the silent feature be "OFF".)

SET THE CTIME FEATURE (SX-V ONLY)



The CTIME feature is initialized OFF. When the CTIME feature is ON the CPU's clock (CPU's date and time) will be displayed at the end of each report. The SX-V has an on-board clock that can be set for date and time. If the CTIME feature is set to CTIME ALL then all SX-V CPU's that call in will have their clock/calendars updated to CTIME (Central Station Receiver Time).

Type: *CTIME ON* <enter> to turn CTIME ON (to display CPU date/time)

Type: *CTIME OFF* <enter> to turn CTIME OFF (no display of CPU date/time)

Type: *CTIME ALL* <enter> to update all SX-V CPU's clock/calendar to CTIME.

NOTE: It is recommended to leave CTIME ALL on periodically or permanently to update the SX-V CPU clocks. It is important to keep this clock updated as the clock determines the time of day that the STIME, weekly tests (sensor 93) reports are called in, and is also used in the EVENT buffer log. Unprogrammed SX-V's automatically have their clocks set regardless of how this option is set.

2.4 COMMANDS THAT AFFECT THE RECEIVER

The following commands are used for setting Receiver Options, controlling phone lines, performing tests and status checks, configuring zones and passwords, plus many other commands. For further information, enter the command and a question mark for the HELP definition of the command.

ALERT	FULLRESTART	RING
ANSWER	HELP	SILENT
BATTERY	MSTATUS	RELEASE
CHANNEL	OPERATOR	RESTART
COMMANDS	OTHER	STATUS
CSDATE	PASSWORD	TEST
CSTIME	PINS	TRAP
CTIME	PTIME	UNIT
DEMOMODE	QUIET	VERSION*
FAULT	RID	

DEFINITIONS

ALERT - Increases annunciation when used with the QUIET command. See Section 2.3 SELECT AND SET RECEIVER OPTIONS.

ANSWER - Answers phone line n (with "n" = line number 1, 2, 3 or 4). See Section 4.4 HOW TO PROGRAM AN UNPROGRAMMED CPU.

BATTERY - Forces receiver to perform a 5 minute backup battery test. See Section 2.5 RECEIVER TROUBLESHOOTING AND SELF TESTS.

CHANNEL - Sets an RS-232 port to interface with computers, printers, terminals etc. See Section 6 INTERFACING PERIPHERAL DEVICES TO THE CS-4000.

COMMANDS - Lists all commands available for use with the receiver. See Section 3.3 THE HELP FEATURE.

CSDATE - Sets the Central Station date. See Section 2.3 SELECT AND SET RECEIVER OPTIONS.

CSTIME - Sets Central Station time. See Section 2.3 SELECT AND SET RECEIVER OPTIONS.

CTIME ON/OFF/ALL - Displays CPU clock at the end of each report (SX-V CPU only). See Section 2.3 SELECT AND SET RECEIVER OPTIONS.

DEMOMODE - Turns ON/OFF the automatic TRAP feature of the CPU jack. See Section 4.4 HOW TO PROGRAM AN UNPROGRAMMED CPU.

FAULT - This command sets automatic testing function(s) for the following Receiver options. See Section 2.3 SELECT AND SET RECEIVER OPTIONS.

FULLRESTART OKAY - Completely resets the Receiver to power up default settings on all options. ALL memory is cleared and all options reset at the completion of this command. See Section 2.5 RECEIVER TROUBLESHOOTING AND SELF TESTS.

NOTE: The Receiver will go blank for approximately 10 seconds after this command is entered. The Receiver performs self-tests at this time.

MSTATUS - Gives a complete listing of all Receiver options listed in STATUS, but includes Full Channel Option listing, PNUM table, TRAP table, OTHER options and the Operator Table. See Section 2.3 SELECT AND SET RECEIVER OPTIONS.

OPERATOR - Sets each Operator Number (up to 20), Password, and Privilege Level. See Section 2.2 SET OPERATOR PASSWORDS.

OTHER - Sets special options for receiving other non-ITI communication formats. See Section 7.2 NON-ITI FORMATS.

PASSWORD - Command sets the privilege level of the operator. See Section 3.5 USE OF THE PASSWORD COMMAND.

PINS - This command will display the current condition of an RS-232 I/O Port. See Appendix B--RS-232 FORMAT AND SIGNAL EXPLANATION.

PTIME ON/OFF - Shows the time since the CPU was armed during an uncanceled alarm. See Section 2.3 SELECT AND SET RECEIVER OPTIONS.

QUIET ON/OFF - Suppresses alert sound for all reports except those that contain an uncanceled alarm or a cancel with no alarm. See Section 2.3 SELECT AND SET RECEIVER OPTIONS.

RELEASE - Closes down CPU communications and hangs up on the current interactive line. See Section 4.2 INTERACTIVE COMMANDS THAT AFFECT A CPU.

RESTART - Forces a RESTART to re-initialize hardware.

RID - Sets Receiver ID for use with special RS-232 channel computer formats. See Section 6.2 COMPUTER INTERFACING.

RING ON/OFF - Turns auto answering either on/off for Phone Line n. See Section 2.3 SELECT AND SET RECEIVER OPTIONS.

SILENT ON/OFF - Silences Receiver annunciator for all incoming calls. See Section 2.3 SELECT AND SET RECEIVER OPTIONS.

STATUS - Immediately updates and displays Central Station hardware status. See Section 2.3 SELECT AND SET RECEIVER OPTIONS.

TEST ON/OFF - Turns Central Station Automatic Phone Test feature either on/off. See Section 2.3 SELECT AND SET RECEIVER OPTIONS.

TRAP aa-aaa - Tells the Receiver to Trap Account Number aa-aaa when it calls the Central Station. See Section 4.3 THE TRAP COMMAND.

UNIT a - Sets Unit ID character for printed output where a = a letter. Default ID is A. See Section 6.5 CUSTOM INTERFACE FORMATTING.

VERSION - Displays the software version date. See Section 2.5 RECEIVER TROUBLESHOOTING AND SELF TESTS.

* - If you want a message to appear on the printer, type an * followed by the message. For example, if you type:

* *Dispatched St. Paul Police*

that message would appear in sequence on the Central Station printout.

2.5 RECEIVER TROUBLESHOOTING AND SELF TESTS

TROUBLESHOOTING

This section covers a general overview of some symptoms and the problems they may generate, along with possible solutions.

Line N Faulty--the Receiver does not detect the phone line voltage of line "n:"

- (1) Is the line plugged into the back of the Receiver?
- (2) Are the connections good on the RJ jack?
- (3) Has the phone company checked the line?
- (4) Does the line receive calls?
- (5) Is the FAULT for that line ON?

The Receiver will not answer Line "n:"

- (1) Is the RING feature ON for that line?
- (2) Is the line faulty?
- (3) Call the Receiver from a telephone--do you hear the handshake tone?
- (4) Try a different jack on the back of the Receiver.

If your keyboard is locked up try one of the following:

- (1) Unplug the keyboard and plug it back in again.
- (2) Hold the CTRL, ALT, and DEL buttons down at the same time to perform a RESTART.
- (3) Press the FAULT RESET button on the back of the Receiver.

The Receiver performed a RESTART:

- (1) Type: *STATUS* <enter>. Have any Receiver Option(s) changed? If so, configure it to the correct setting.
- (2) Did you lose AC power without battery back-up? If so, the Receiver will RESTART when AC power is removed and there is no back-up battery. Type: *STATUS* <enter> and check the Receiver Options.
- (3) Call ITI with the information from the printer at time of occurrence.

You have lost your Master Password:

- (1) Get your MSTATUS list or enter MSTATUS at this time.
- (2) This MSTATUS list is necessary since the only way to Reset the Master Password is to perform a FULLRESTART. Remember a FULLRESTART will also set all Receiver Options to the Power Up default settings.
- (3) Type: *FULLRESTART OKAY* <enter>
- (4) Refer to Section 2.1 INITIAL SETUP.

SELF TESTS

The CS-4000 performs various self tests. Many of these tests are taking place at all times, others on power-up and some by command.

The CS-4000 is equipped with a built in lithium battery which holds the RAM memory should there be a total power loss. This feature allows the CS-4000 to power up to previous Receiver Options and to retain screen memory previously stored.

Tests on Power-up or System Restart:

ROM Module	Real time clock
RAM Module	Keyboard controller
CPU and associated components	Phone line controller
Serial port controllers	CRT Controller

If a problem is detected in any of the above tests, the Receiver will output a series of beeps indicating which test failed. After approximately 60 seconds, the failed test will be bypassed and the Receiver will attempt to restart.

NOTE: If one or more of the above tests fails, the Receiver should be returned for service as soon as possible.

Other tests on power up or restart:

- AC/ Power
- Backup Battery

NOTE: The CS-4000 will alert Low Backup Battery until a sufficiently charged 12 VDC Backup Battery has been connected and checked by the daily noon test or with BATTERY ON command.

Tests every half hour:

- Battery fuse
- Line fault conditions
- Status of backup battery annunciated and displayed every half hour if faulty at last test.

Tests continuously:

- Presence of A/C Power
- Presence of Printer and/or Computer (ACK and DSR Timeouts)

Tests every minute:

Validity of all system parameters and tables stored in RAM. If problem detected, that parameter or table will be reset to power up default settings and a message displayed.

Tests every day:

Backup Battery is tested everyday at noon.
 Backup Battery must power Receiver for 5 minutes without dropping below 11.0 V.
 The results of this test are saved and displayed every half hour if faulty.

Tests by command:

The STATUS command will evaluate and display the condition of the Receiver Options. To perform this command and test the Receiver Options:

Type: *STATUS* <enter>

NOTE: This also applies to the FAULT and STATUS commands.

The BATTERY command puts the Receiver on battery back up test for 5 minutes. The Receiver will test the battery condition and go to back to AC power after 5 minutes. The screen may compress after this command is entered. This is normal. To test the back up battery:

Type: *BATTERY ON* <enter>.

The VERIFY command checks each Table in RAM memory. To enter command:

Type: *VERIFY* <enter>

RECEIVER FAIL

In the event the Receiver detects a problem in the self tests, it will display a message detailing what the specific problem is. This message will be highlighted and also have a short message with it:

Example: RECEIVER FAIL! Pnum Table xx

If a Receiver Failure occurs, perform a STATUS check on that item listed. You may have to re-enter the information so keep a STATUS List near the Receiver.

NOTE: PLEASE WRITE THE INFORMATION DOWN CONCERNING THE FAILURE AND NOTIFY ITL.

POWER LOSS

The Receiver will switch to Battery Backup immediately in the event of AC Power failure. The Receiver will also go back to AC power when it has been restored.

RECEIVER TROUBLE

In the event of a trouble condition, the Receiver will display the trouble and sound the annunciator until the problem has been corrected.

VERSION DATE

To find the Version Date of your software:

Type: *VERSION* <enter>

FULLRESTART OKAY

Entering the command FULLRESTART OKAY does the following

- (1) Screen goes blank for 7 seconds.
- (2) ALL Receiver Options are set to factory default settings listed in Section 2.3--
SELECT AND SET RECEIVER OPTIONS.
- (3) All RAM memory is cleared, including the screen memory and each memory
buffer for Channels 1,2, and 3.
- (4) The CS-4000 must now be configured to your selection of Receiver Options.

WARNING: Be certain to have a hard copy of a complete and up to date MSTATUS report before entering this command.

RESTART OKAY

Entering the command RESTART OKAY is like a rebooting on a PC Computer--the options are not changed. There are two other ways to accomplish a RESTART OKAY. Press the FAULT RESET button on the back of the Receiver or press <CTRL>, <ALT>, AND keys simultaneously. This does not change your Receiver Options.

SECTION 3

OPERATING THE CS-4000

3.1 RECEIVER CONTROLS AND HARDWARE

The Receiver has numerous controls and functions. This section will familiarize you with their use.

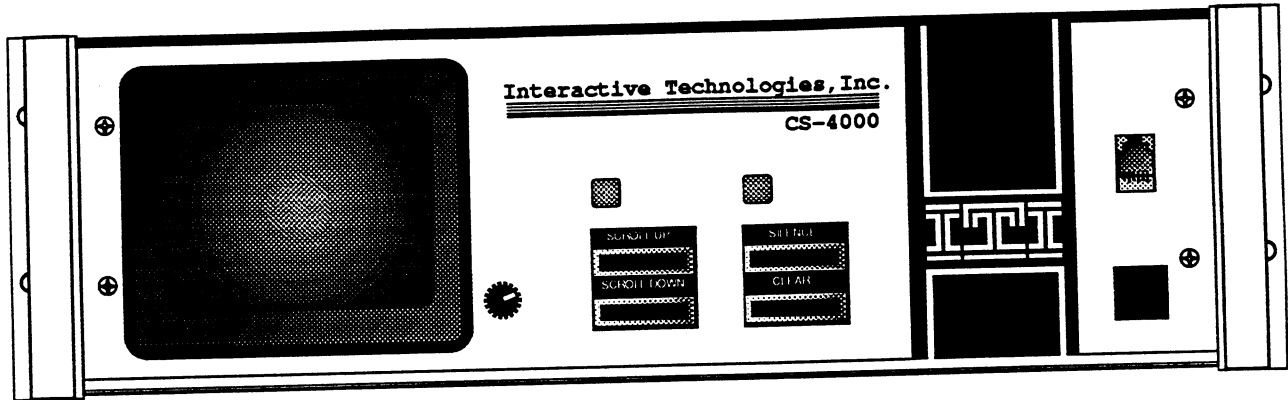

THE CRT AND CRT BRIGHTNESS CONTROL

The built-in CRT is located on the left side of the front panel. The CRT Brightness Control is located near the lower right corner of the CRT. To control the brightness turn the knob clockwise for a brighter screen or counterclockwise for reduced brightness. Alarm messages are highlighted and will flash on the CRT.

THE SILENCE, CLEAR, SCROLL UP AND SCROLL DOWN BUTTONS

DEFINITION: SCROLL--The list of reports shown on the display is designated as the SCROLL of events.

There are four push buttons located in the center of the front panel. (See section 3.4 READING THE CRT DISPLAY for more information) Their functions are:

SILENCE BUTTON--quiets the annunciator when it is pressed.

CLEAR BUTTON-- acknowledges the oldest (chronological order) message waiting in Receiver memory when it is pressed.

SCROLL UP BUTTON--backs up one full screen of CRT display for review of previous information.

SCROLL DOWN BUTTON--advances the display forward by half screens until you reach the current display.

POWER AND ALARM LIGHTS

The Power Light will be lit when AC and/or battery power has been applied to the Receiver.

The Alarm Light will flash when one or more alarm messages are waiting to be acknowledged or cleared.

KEYBOARD JACK

The Keyboard Jack is located near the lower right corner of the front panel. It will accept the connecting cord from the Keyboard only.

CPU (PROGRAM) JACK

The CPU (Direct Program Jack) is located on the upper right corner of the front panel. This is to be used **ONLY** for direct programming of a CPU (not using telephone lines). This jack will accept only the (8-position) RJ-31X cord supplied with the CPU. Direct CPU programming is accomplished by connecting the CPU to the Direct Program Jack located on the front of the Receiver. This jack is not equipped to handle the voltage from a live telephone line. Also, a standard telephone cord is a 6 position cord and will not fit into the Program Jack. See the last page of Section 4.4.

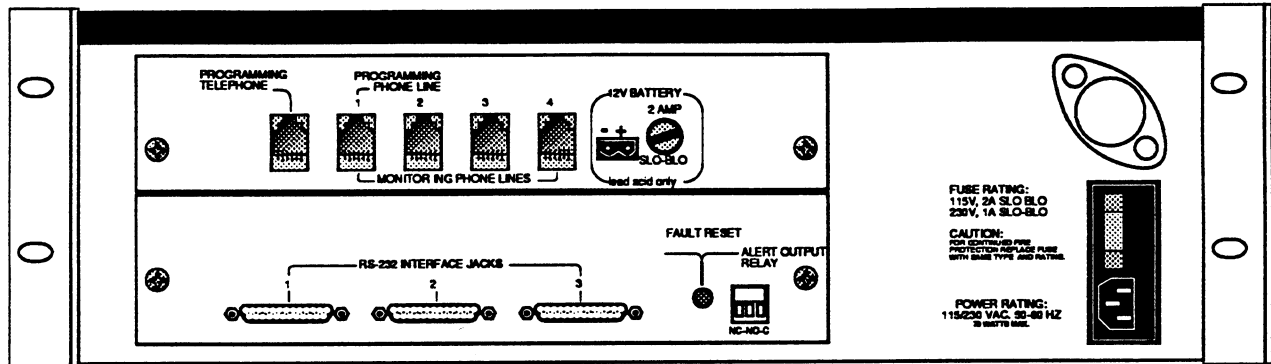

WARNING DO NOT CONNECT A PHONE LINE TO THE DIRECT PROGRAM JACK!! DOING SO WILL DAMAGE THE RECEIVER!!

RESET BUTTON

The FAULT RESET button is located near the lower center on the *back* of the Receiver. When the FAULT RESET button is pushed it will cause a RESTART OKAY to be executed. This will reset all Receiver options to those last set by the operator and will also allow the Receiver to run the self test program.

BACKUP BATTERY CONNECTION

The Backup Battery Connection is located to the right of the telephone jacks on the back of the Receiver. A two-pin connector is supplied to connect the battery to the Receiver. Use a 12 V DC battery only! A YUSA NP38-12 (38 amp hour) gel cell or equivalent is recommended (for U.L. requirements). This will give approximately 24 hours of battery back up. The CS-4000 draws approximately 1.3 amps at 12 VDC.

A/C and BATTERY FUSES

The Battery Fuse is located next to the Backup Battery connection. The fuse is a 3AG slow blow 2 amp 250 V fuse. The A/C fuse is located above the AC power cord connection on the right side of the back of the Receiver. This is also a 3AG slow blow 2 amp 250 V fuse.

AC POWER CONNECTION

If 115 VAC is to be used, connect the power cord to the receptacle on the back of the Receiver.

If 220 VAC power is to be used, a card must be removed from the A/C power cord receptacle. This card is located to the right of the A/C fuse holder. First pull out the A/C fuse. This allows easy access to the 120/240 selection card. The card has a hole located on the middle of the outer edge of the board. Pull the card out, turn it around and re-insert it into the receptacle. After installing it, the number 220 should be visible. This allows the Receiver to utilize 220 VAC. Then replace existing fuse with a 220 VAC 3AG, 1 amp slow blow.

3.2 KEYBOARD FUNCTIONS



<ENTER> KEY

This Key is used to enter commands to the Receiver. After typing a command, press the <enter> to effect the command. For example, to enter the command STATUS:

Type: STATUS <enter> to enter the command on the Receiver.

NOTE: Pressing <enter> will always cause the scroll to display the current screen.

BACK SPACE KEY

This key is located directly above the enter key, it is an arrow pointing to the left (<—). This key is used to undo wrong information before pressing the <enter> key.

F1 to F10 KEYS

These keys are located on the left side of the keyboard. Each "F" Key has a unique function as listed below:

- <F1> Inputs a blank line in order to advance a connected printer.
- <F2> Acknowledges the oldest unacknowledged report (identical to the CLEAR button).
- <F3> Silences the annunciator (identical to the SILENCE button).
- <F4> Acknowledges ALL unacknowledged reports.
- <F5> Displays last command entered (will go back to the previous five commands maximum).
- <F6> Displays the next command (when using the <F5> key to scroll back to an earlier command).
- <F7> Not used.
- <F8> Not used.
- <F9> Prints date and time and performs a short system checkout test.
- <F10> Displays the HELP message.

A short description of each "F" Key appears on the CRT screen at all times.

KEYPAD

The Keypad on the right side of the Keyboard has ten functions.

<u>Key Number</u>	<u>Description</u>	<u>Function</u>
1	End	--scroll to current screen
2	Down Arrow	--scroll forward one line
3	Page Down	--scrolls down one-half screen of data (identical to SCROLL DOWN button).
4	Left Arrow	--scroll back to last report
5	STOP	--stops the screen from scrolling.
6	Right Arrow	--scroll forward to next report
7	Home	--earliest information in screen memory
8	Up Arrow	--scroll back one line
9	Page Up	--scrolls back one screen's worth of data (identical to SCROLL UP button).
*	Asterisk	--prints out typed message without getting error message (if you want a message to appear on the printer, type an * followed by the message).
+	Plus sign	--used to stop the automatic STATUS listing of the following commands: CHANNEL, LEVEL, MACCESS, OPTION and XACCESS. See Section 4.7 SX-V ONLY COMMANDS.

3.3 HELP FEATURE

The HELP feature gives you a short definition and example of commands used with the Receiver. These HELP messages (bordered on the top and bottom of the message by asterisks) will not appear on the printer. By pressing <F10> key or typing HELP you will obtain a list of the different HELP categories. They are as follows:

HELP RECEIVER--a list of commands that affect the Receiver
 HELP INTERACTIVE--a list of commands that affect a CPU
 HELP I/O--a list of commands for the RS-232 Interface ports
 HELP KEYS--a list of F keys and 10-Key Keypad functions
 HELP CPUPROG--how to program an unprogrammed CPU

Example: To view one of these HELP lists, in this example the HELP CPUPROG:

Type: *HELP CPUPROG*<enter>

All commands in each category are listed with a short definition. To find further information on a specific command you enter that command followed by the <F10> Key or by typing HELP followed by the desired command.

Example: For more information on PHONE command.

Type: *HELP PHONE* <enter> , or
 Type: *PHONE HELP* <enter> , or
 Type: *PHONE* <F10>

Either method will give you a more detailed explanation of the command and also examples of its usage.

NOTE: Since some commands are under a LOW or HI or MASTER privilege level, you will have to attain that privilege level before getting the HELP information.

A list of all commands available in the CS-4000 can be obtained:

Type: *COMMANDS* <enter>.

3.4 READING THE CRT DISPLAY

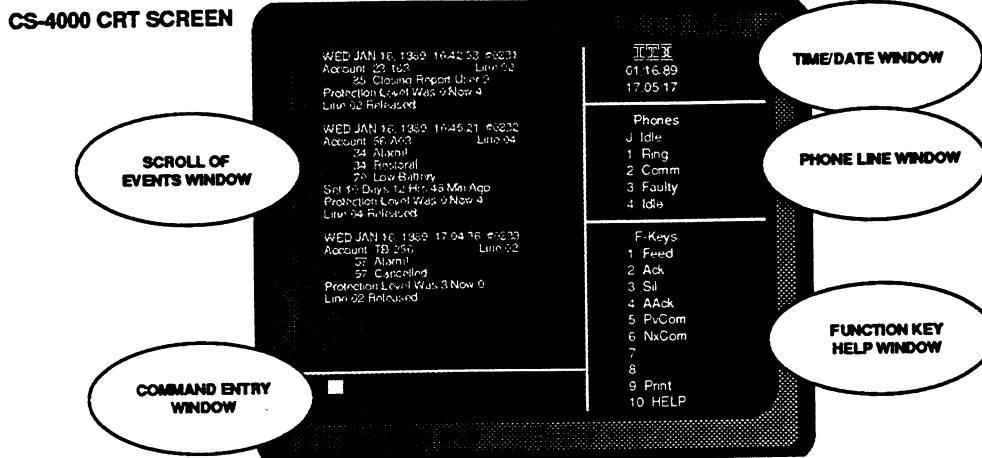

WINDOWS

The built-in CRT of the CS-4000 displays five types of information. Each type has its own display area, called a window. The information and location of each of the windows is summarized below:

- The large window to the left of the screen is the **SCROLL OF EVENTS WINDOW**
- The **COMMAND ENTRY WINDOW** is below the Scroll of Events and displays any command you are entering.
- TIME/DATE** is displayed in the small window on the top right side of the screen .
- The **PHONE LINE STATUS WINDOW** is displayed below the Time/Date.
- The **F KEY HELP WINDOW** list is on the bottom window on the right side.

ALARM MESSAGES

All messages on the **SCROLL OF EVENTS** window (alarm reports, error messages, commands entered, and results of those commands) are displayed on the screen, but those requiring the Operator's immediate attention are highlighted. The highlighted commands will flash and the annunciator will sound until the Operator has attended to the alert. A highlighted, flashing message (with annunciator) can be acknowledged by pressing the Clear Key on the front panel (or the F2 Key on the keyboard). The annunciator can be silenced by pressing the Silence key on the front panel (or the F3 key on the keyboard).

THE SCROLL OF EVENTS WINDOW

The CRT will display reports as they are received in chronological order--the latest report being the lowest on the screen.

DEFINITION: This list of reports is called the "SCROLL" of events. From this point on, the list of reports will be referred to as the "Scroll of Events."

TROUBLE INDICATIONS

Periodic pulsing of the internal CS-4000 Receiver audible at 2 second intervals with the screen blank indicates that the receiver is not functioning. **CALL FOR SERVICE.**

Example: (Assume an empty screen.)

A phone test is received. It is followed by an opening report, then an alarm call. The phone test will be at the top of the screen. Below it, the opening report will be displayed, and lastly, the alarm report will be shown. The alarm report is the latest (most current) report and is displayed lowest on the screen.

For ease of explanation, say another report is received and the screen is now full. (The lowest report on the screen is always the most current.) Now another report is received. It is displayed at the bottom of the screen (it's the most current report). Since the screen is full, each report moves up, and the report at the top of the screen (the earliest report) is put into screen memory to make room for this report. As more reports come in, each message moves up another space, with the report at the top of the screen entered into screen memory.

NOTE: Although screen memory can store many reports, the memory space is limited. The screen memory will always be updated with new reports, and the earlier reports will be dropped from screen memory when it is full and new reports are added.

USING THE SCROLL UP BUTTON TO REVIEW SCREEN MEMORY

To view the first reports in the previous example, you would press the SCROLL UP button on the Receiver front panel. By pressing the SCROLL UP button (or Page Up #9 on the 10-Key Keypad), the Receiver will *look back one full screen* of memory and display one full screen of previous messages.

Example:

For purposes of explanation only, we will assume that four reports fill one screen (in reality report size may vary and so will the number of reports to fill one screen). In this case, we will also assume that twelve reports have been received so far. If you want to view one of the first four reports, pressing SCROLL UP two times will get you to those reports (as each depression of the SCROLL UP button goes back one screen).

To advance the SCROLL *forward one-half screen*, press the SCROLL DOWN button (or Page Down, #3 Key, on the 10-Key Keypad). Each time the SCROLL DOWN button is pressed, the SCROLL will be advanced one-half screen towards the more recent reports.

To advance the SCROLL *forward line-by-line* press the #2 Key (the arrow pointing down on the 10-Key Keypad). This will advance the SCROLL towards the most current reports.

NOTE: Screen memory is designed to allow reference back to a limited number of reports. A hard copy from the printer should be kept for record purposes.

Program commands are displayed in the command window below the Scroll Window. When a programming command is entered the Receiver will display the current condition of the STATUS of that command and also the information you have just entered.

PHONE WINDOW

When the CS-4000 is receiving a call, there are numerous messages that may appear in the Phone Window next to the line number where the call is being received.

IDLE--The phone line is "good" and in an idle state.

ESUP--The Receiver is answering the line and giving the echo suppressing tone. This tone disables echo suppressors on long distance lines.

COMM--The Receiver is attempting to, or in the process of, communicating with the CPU. Upon completion of the ESUP tone the Receiver will display the COMM message as it sends out the ITI handshake.

HOLD--The Receiver has put the CPU on hold either to answer another line or while waiting for the next Interactive command.

RING--The Receiver is detecting a RING.

LISTEN--The Receiver has given a handshake signal and is now listening for a response from a CPU.

1400--The Receiver is sending out the 1400 HZ handshake signal in an attempt to answer a non-ITI format or the Receiver is sending the 1400 HZ KISSOFF signal in response to valid data received.

2300--The Receiver is sending out the 2300 HZ handshake signal in an attempt to answer a non-ITI format or the Receiver is sending the 2300 HZ KISSOFF signal in response to valid data received.

RNGOFF--The auto-answer mode has been disabled for this line. It will detect and display RING signals but will not automatically answer. The only way to answer a CPU on a line that has RING function turned OFF would be to type ANSWER n, where n = line number.

WARNING: The RING OFF option should never be enabled on a line used for monitoring as it will result in missed alarm reports.

3.5 USE OF THE PASSWORD COMMAND

There are two types of commands in the CS-4000: those which do not require a password and others that require an operator to use their password to become privileged. An operator is assigned a number, a password, and a Privilege Level of LOW, HI, or MASTER. (Refer to the SELECT AND SET OPERATOR PASSWORDS and LEVELS section.)

By entering the following command, the Operator will get privileged at their particular level:

Type: *PASSWORD n %pswd* <enter> (with "n" = Operator Number and %pswd the Operator's Password preceded by a % sign).

COMMANDS NOT REQUIRING A PASSWORD ("NO-LEVEL")

ANSWER	PINS	STATUS
COMMANDS	PORT(S)	UPDATE
ERASE	RECALL	VERIFY
FULLRESTART	RELEASE	VERSION
HELP	REPEAT	XON
PASSWORD	RESTART	ZONE(S)

LOW-LEVEL PASSWORD COMMANDS - The Low Level Password privilege allows the operator to use these additional commands:

ACCOUNT	EXIT	PTFREQ
ALERT	FAULT	PTIME
BATTERY	GROUP	QUIET
BUDDY	INITIALIZE	RID
BYPASS	MGROUP	RING
CHANNEL	MINITIALIZE	RESTORE
CSDATE	OTHER	SILENCE
CSTIME	ONLINE	STIME
CTIME	PHONE	TEST
DEMOMODE	PHONE2	TIMEOUT
ENTRY	PMODE	TRAP
EVENT	PNUM	UNIT

HI-LEVEL PASSWORD COMMANDS - The Hi Level Password privilege allows the Operator (Central Station Manager or Supervisor) access to all commands listed above plus:

ACCESS	DURESS	MDELETE
CPUTIME	HOUSE	OPTION
DELETE	IDBUFFER	PLEVEL
DIALBACK	LEVEL	XACCESS
	MACCESS	

MASTER LEVEL COMMAND - Only the Master Password Holder (Operator 1) can perform the OPERATOR command, which sets up each Operator Number, Privilege Level and Password. The MASTER can perform *all* commands. You will notice that Low Level Privilege commands allow only the entry or addition of information while the Hi Level Privilege commands can delete, bypass or change/disable a system's arming capabilities.

EXAMPLE OF THE PASSWORD COMMAND

There are four Privilege Levels as well as four levels of commands. As shown above each privilege level (none, Low, Hi, and Master) has a set of commands that can be performed at that Privilege Level.

- Any operator can use the No Level Commands
- The Low Privilege Level Password operator can use the Low Level Password Command and the No Level Commands
- The Hi Privilege Level Password Operator can use the Hi Level, Low Level and No Level commands
- The Master (operator 1) can use *all* commands and is the only one able to do the OPERATOR command.

NOTE: When a password has been entered correctly, the Operator is privileged at their particular level for 10 minutes. The Receiver automatically resets the timer for 10 additional minutes when the last command is entered in the first 10 minutes. The Operator who has large amounts of programming to do will not be interrupted by the expiration of the password privilege level in 10 minutes.

To use the PASSWORD Command

Type: *PASSWORD n %pswd* <enter>
 where "n" = Operator Number and %pswd the Operator's Password preceded by % sign).

The Password will be displayed by asterisks (i.e. hidden) on the screen.

USE OF THE LOW LEVEL PASSWORD

Example: You want to enter a phone number into a CPU's memory. If you DO NOT enter your Low Level Password (*PASSWORD n %pswd*) before the phone command:

Type: *PHONE 123-4567* <enter>.
 Reply: ERROR: Low Privilege Command!

You must enter your Low Level Password at this time. When you get a reply that asks for a Password you must enter that Password before entering the command.

The Correct Procedure:

Type: *PASSWORD n %pswd* <enter>
 Reply: Privilege Level set to Low
 Ready
 Type: *PHONE 123-4567* <enter>.
 Reply: READY

Entering your Low Level Password before the command gives you a privileged status and allows you to enter those commands under the Low Level Password.

USE OF THE HI LEVEL PASSWORD

Example 1: You want to delete sensor 30. If you DO NOT ENTER your Hi Level Password before the Phone Command the following will happen:

Type: *DELETE 30* <enter>.
Reply: ERROR: Hi Privilege Command!

You must enter your Hi Level Password at this time. When you get a reply that asks for a Password you must enter that Password before entering the command.

Type: *PASSWORD n %pswd*<enter>.
Reply: Privilege Level set to HI
Ready
Type: *DELETE 30*
Reply: READY

Entering your Hi Level Password gives you a privileged status and allows you to enter all Hi and Low Level Password commands.

PASS PERMANENT

If you do not feel there is a need for your Password (either Low or Hi Level), you may make your Password Privilege Permanent. If you want to make your Password Permanent, the PASSWORD PERMANENT command allows you to do this. Once your Password is Permanent, you will not have to enter your Password to get privileged again.

NOTE: You will only be privileged for your Password Level (either Hi or Low).

Type: *PASSWORD n %pswd* <enter>.
Reply: Privilege Level is set to HI
Type: *PASSWORD PERMANENT*<enter>.
Reply: Privilege Level is set to HI
Privilege Level is Permanent

To turn OFF your PERMANENT PASSWORD

Type: *PASSWORD OFF* <enter>.

If your Password is permanent it will show up on a STATUS command as:

Privilege Level is set to HI
Privilege Level is Permanent

SECTION 4

PROGRAMMING AN ITI CPU

4.1 INTRODUCTION

This section refers to the ability of the CPU to report in ITI's Interactive format, such as the SX-III, SX-IV, SX-V and the Commander.

The ITI CPU requires a phone number and account number to be programmed into its memory in order to communicate with the Central Station. A new or unprogrammed CPU must be programmed with a phone number so it knows what number to dial in order to reach the Receiver and an account number for identification.

This is accomplished by "Interactive programming." Our definition of "Interactive" is a *two-way communication between the CPU and the Receiver via telephone lines*. This connection allows the operator to enter information into CPU memory and also to determine what information has already been programmed.

To become Interactive, the operator must first set a TRAP for that CPU. Once that is done, the next step is to make a connection in one of two ways: 1) Call the installer at the site of the CPU, or 2) Have the installer (customer) send a PHONE TEST, if the CPU is already programmed. Once the TRAP has been set, and the connection made by a PHONE TEST, programming may begin.

If you are new to the ITI system, the following is a suggested checklist for programming a CPU.

1. If the CPU is unprogrammed, see Section 4.4 HOW TO PROGRAM AN UNPROGRAMMED CPU, then proceed to Step 2.

If the CPU is already programmed into the Central Station, see Section 4.3 THE TRAP COMMAND, then proceed to Step 2.

If the CPU is programmed with an incorrect phone number, see Section 4.5 REPROGRAMMING A CPU WITH AN EXISTING PHONE/ACCOUNT NUMBER, then proceed to Step 2.

2. If additional programming is required after the phone and account numbers have been established, use the chart on the next two pages to locate detailed explanations on any additional commands.
3. Remember that any command is also explained by using the HELP feature (Section 3.3).
4. Always check your work after entering the UPDATE and ERASE commands. The use of these two commands forces the Receiver to ask the CPU for information when you verify that the commands and data entered are correct. Refer to Sections 4.3 or 4.4. for examples of the use of UPDATE and ERASE commands.

This section gives an overview of all commands that could be used while programming a CPU. The commands are listed in alphabetical order along with required Password Level, a short description of the command's use, and the page number where it is explained in detail.

COMMAND	PASSWORD LEVEL	PAGE	DESCRIPTION
ACCESS	HI	39	Access code in CPU
ACCOUNT	LOW	39	Account Number in CPU
ANSWER	None	39	Tells receiver to answer a line
BUDDY	LOW	39, 72	Sets up a Buddy System with another SX-V CPU
BYPASS	LOW	40	Bypasses a zone in the CPU
CPUTIME	HI	40, 73	Sets the time in the SX-V CPU
DELETE	HI	40	Delete a sensor from CPU memory
DIALBACK	HI	40, 73	Tells the SX-V CPU to dial back in "n" minutes
DURESS	HI	40	Duress code in CPU
ENTRY	LOW	40	Controls entry delay time in the CPU
ERASE	None	40	Erases information in temporary memory of the Central Station
EVENT	LOW	40, 73	Displays the events in the SX-V CPU buffer
EXIT	LOW	40	Controls exit delay time in the CPU
GROUP	LOW	41, 62	Changes the characteristics of a sensor
HOUSE	HI	41	House code in CPU
IDBUFFER	HI	41, 73	Displays the house codes of sensors that CPU has heard transmit that are not of the same house code. (SX-V only)
INITIALIZE	LOW	41	Adds a Zone in the CPU
LEVEL	HI	41, 73	Controls whether an arming level is armed, disabled or restricted in a CPU See Appendix D also.
MACCESS	HI	41, 74	Sets ACCESS codes and privilege levels for SX-V CPU user's 1 through 10. RF Commander & Commander (2-6) OEM RF Commander (2) Note: The only panel which modifies levels for the access codes is the SX-V.

MDELETE	HI	41, 68	Deletes a group of consecutive sensor numbers
MGROUP	LOW	41, 66	Regroups multiple consecutive sensors to same group number and letter code
MINITIALIZE	LOW	41, 67	Initializes multiple consecutive sensor numbers
ONLINE	LOW	N/A	Same as Phone command (obsolete)
OPTION	HI	41, 75	Sets the SX-V "F" options
PHONE	LOW	42	Phone number in CPU
PHONE n	LOW	42	Phone number in CPU using PNUM phone numbers
PHONE OFF	LOW	42	Erases phone number in CPU
PHONE2	LOW	42	Secondary phone number in CPU
PLEVEL	HI	42	Controls arming level in CPU
PMODE	LOW	42	Controls which of 4 ways the CPU will use the phone numbers set by the PHONE and PHONEZ commands.
PORT	None	43	See Zone command (Obsolete)
PTFREQ	LOW	43, 75	Sets the time in days of the automatic phone test (SX-V CPUs only)
RECALL	None	43	Tells the CPU to hang up and call back immediately
RELEASE	None	43	Updates CPU with changes in the temporary memory and releases phone lines
RESTORE	LOW	43	Restores a bypassed sensor in CPU (removes bypass on sensor)
STIME	LOW	43	Controls time of day that supervisory and low battery reports are called into Central Station
TIMEOUT	LOW	43	Siren timeout in CPU, for exterior sirens and high level sounds from interior sirens
TRAP	LOW	44, 45	Tells the Receiver which account number to trap for Interactive programming
UPDATE	None	44	Sends all commands that have just been entered to CPU memory
XACCESS	HI	44, 75	Sets ACCESS codes and privilege levels for SX-V CPU users 11 through 33.

ZONES

None

44, 81

Displays the characteristics of the Zone
Identical to Ports command (new)

4.2 INTERACTIVE COMANDS THAT AFFECT A CPU

ACCESS - The access command sets or finds the CPU's four digit access code.

Type: *ACCESS STATUS* <enter>, or *STATUS*, to display the CPU access code.

Type: *ACCESS nnnn* <enter> to set CPU access code where "nnnn" is a 4 digit number. *ACCESS* codes cannot be set the same as *DURESS* codes.

ACCOUNT - Controls the account number stored in the CPU.

Type: *ACCOUNT STATUS* <enter>, or simply *ACCOUNT*, to display the CPU's current account number.

Type: *ACCOUNT aa-aaa* <enter> (where a = alphanumeric character).

WARNING! Do not use the letter **X** for any account number because the Receiver uses **X** in the prefix of an account number for a Non-ITI panel.

The 5 digit (aa-aaa) account number is hyphenated to facilitate definition of a specific dealer, city or state, or to distinguish between various types of accounts. **YOU MUST INCLUDE THE HYPHEN!**

Example:

Account Number 24-10B may be broken down as follows:

--24 identifies dealer #24.

--10B identifies the particular subscriber serviced by dealer #24.

Example:

Account number NJ-342:

--NJ identifies this as an account from New Jersey.

--342 identifies the subscriber.

It is important not to use look alike letter/number combinations. For example, 5 and S, Z and 2, I and 1 can be easily mistaken for each other.

ANSWER - This command is used to manually answer a CPU to allow you to become Interactive with it. See Section 4.4 PROGRAMMING A CPU and Section 4.5 REPROGRAMMING AN EXISTING PHONE NUMBER OR ACCOUNT NUMBER.

Type: *ANSWER n* <enter> with "n" = 1,2,3 or 4, to answer a CPU on Line n.

BUDDY-To set up the Buddy System with a nearby SX-V CPU: See Section 4.7 SX-V ONLY COMMANDS.

BYPASS - This command causes a zone in the CPU to be bypassed. The bypassed zone is prevented from generating any alarms or causing any communication to the Central Station until the customer changes the protection level of the CPU or uses the RESTORE command.

Type: *BYPASS pp* <enter> where "pp" = bypassed zone number

CPUTIME - Sets the CPU time/date to the receiver time/date. See Section 4.7 SX-V ONLY COMMANDS.

DELETE - This command will delete a sensor from the CPU's memory.

Type: *DELETE zz* <enter> where "zz" = zone number

DIALBACK- Instructs the CPU (SX-V only) to hang up and dial back to the receiver in "n" minutes. See Section 4.7 SX-V ONLY COMMANDS.

DURESS - This command sets the CPU's duress code or finds the setting.

Type: *DURESS STATUS* <enter> (or simply DURESS) To display the CPU's two digit duress code.

Type: *DURESS nn* <enter> where "nn" = last two digits of duress code 00 to 99. Only the last two digits are set; the first two remain the same as the access code. The DURESS code cannot be set the same as the ACCESS code.

ENTRY - This command can set the length of the entry delay or finds what the setting is. It is preset at 32 seconds and can be changed from 04 to 60 seconds maximum (rounded down to a multiple of 4, e.g. if you enter 45 seconds, it would be rounded to 44 seconds).

Type: *ENTRY STATUS* <enter> (or simply ENTRY) to display the ENTRY delay time in seconds.

Type: *ENTRY nn* <enter> "nn" = delay time in seconds.

ERASE - This command is used following the UPDATE command to erase the Receivers temporary memory of what it has determined is programmed into a CPU. This forces the Receiver to retrieve programming information from the CPU when you are verifying your work.

EVENT- The event command will display the previous events in the event buffer of the SX-V. See Section 4.7 SX-V ONLY COMMANDS.

EXIT - This command sets the time of the exit delay or finds its setting. It is preset at 32 seconds and can be changed from 4 to 60 seconds maximum (rounded down to a multiple of 4).

Type: *EXIT STATUS* <enter>(or simply EXIT) to display the EXIT delay time in seconds.

Type: *EXIT nn* <enter>"nn" = 04 to 60 seconds exit delay time

GROUP: The Group command allows you to change sensor characteristics. See Section 4.6 THE GROUP COMMAND.

HOUSE - This command sets the House Code or finds the setting in the CPU

Type: *HOUSE STATUS* <enter>(or simply HOUSE) to display the current House Code in the CPU.

Type: *HOUSE nn* <enter> where "nn" =00 to 03, to set the house code (SX-III, SX-IVA and SX-IVB CPU's only)

Type: *HOUSE nnn* <enter> where nnn = 001 to 254, to set the house code (SX-V only)

ID BUFFER - This command will cause the Receiver to display the House Codes in the SX-V CPU ID Buffer of any SX-V system nearby that is in receiving range of the CPU. See Section 4.7 SX-V ONLY COMMANDS.

INITIALIZE - This command will initialize (add) a sensor to the CPU's memory.

Type: *INITIALIZE pp* <enter>where "pp" = sensor number

LEVEL - This command controls the ten arming levels of the CPU. For example, you might want to have only Level 0 (Disarm) and Level 4 (Away) armable in a commercial system. You could then disable 1-3 and 5-7. See Appendix D.

Type: *LEVEL STATUS* <enter>
(or simply LEVEL) to display the ten arming levels of the CPU and whether each is "armable" or "disabled".

Type: *LEVEL n ON* <enter> to enable the CPU to be armed to Level n, "n" = a number between 0-9.

Type: *LEVEL n OFF* <enter> to disable the CPU so it cannot be armed to Level "n" arming level

Type: *LEVEL n RESTRICT* --See Section 4.7 SX-V ONLY COMMANDS.

MACCESS - Allows you to set the Access Code and Privilege Level of each of the multiple Access Code Users 1 through 10; also identifies which user initiated opening or closing report. See Section 4.7 SX-V ONLY COMMANDS. Also see the Commander Section.

MDELETE - This command allows the operator to delete a group of consecutive sensor numbers. See Section 4.6 THE GROUP COMMAND.

MGROUP - Allows the operator to change the Group number and Letter code of a range of consecutive sensors. See Section 4.6 THE GROUP COMMAND.

MINITIALIZE - (MINIT for short) Allows the operator to initialize a group of consecutive sensors. See Section 4.6 THE GROUP COMMAND..

OPTION - Sets SX-V "F" options. See Section 4.7 SX-V ONLY COMMANDS

PHONE - Enters the PHONE number in the CPU's memory.

Type: *PHONE nnn-nnnn* <enter>
where "nnn-nnnn" = phone number (may have up to 14 digits).

Type: *PHONE n* <enter>
where "n" = PNUM A,B,C...J

Type: *PHONE OFF* <enter> to erase the phone number in the CPU.
Upon completion of this command phone numbers will be displayed as "Not Initialized"

PHONE2 - This command enters the secondary phone number in the CPU that is used with the PMODE command.

Type: *PHONE2* <enter> to enter the second phone number in the CPU's memory (same as PHONE format, but use PHONE2).

PLEVEL - This command sets a protection level (arming level) of the CPU from Levels 0 through 9. (Any open sensors will be bypassed.)

Type: *PLEVEL* <enter> to display current protection level of CPU.

Type: *PLEVEL n* <enter>
where "n" = a number from 0 to 9.

NOTE: The PLEVEL n command causes the customers CPU to reset and thus a Code 95 will report to the Central Station indicating an AC restored. This is normal in all panels except the SX-V.

PMODE - The SX-IVB CPU has the ability to call two phone numbers if desired. There are five options to choose from. These are controlled by the PMODE COMMAND.

Type: *PMODE STATUS* <enter> (or simply PMODE) for the Receiver to display the current value of the secondary phone mode ranging from 0 to 4 where:

- 0 = Second phone number not used.
- 1 = Second phone number is called only if the CPU fails to get through to first number.
- 2 = First number reports all alarms except LOW BATTERY and SUPERVISORY. The second reports only LOW BATTERY and SUPERVISORY.
- 3 = First number reports all alarms, except LOW BATTERY and SUPERVISORY. The second phone number reports everything.
- 4 = First number reports all alarms, except LOW BATTERY, SUPERVISORY, OPENINGS and CLOSINGS. The second number reports everything. (SX-V CPU only.)

Type: *PMODE n* <enter>
where "n" = 0, 1, 2, 3 or 4 to set PMODE status.

NOTE: WHEN USING A PMODE OPTION YOU MUST ALSO PROGRAM IN A SECOND PHONE NUMBER--PHONE2.

PORT - See ZONE command.

PTFREQ - Sets the time in days between the automatic phone tests in SX-V CPU. See Section 4.7 SX-V ONLY COMMANDS.

RECALL - This command tells the CPU to hang up and call the Receiver back immediately.

Type: *RECALL* <enter> to instruct the CPU to hang up and call the Receiver back immediately

RELEASE - This command causes the Central Station to complete all communication with the CPU and hang up the phone line. This command also updates the RAM memory on the CPU (sends all of the information that was added or changed).

Type: *RELEASE* <enter> to release the CPU

RESTORE - When a sensor has been BYPASSED you must RESTORE it if you want to put it back into service. (The next time someone changes the protection level also restores bypassed sensors.)

Type: *RESTORE nn* <enter>
where "nn" = a two-digit zone number that you want to restore and put back into service.

STIME - This command sets the time of day (on a 24 hour clock) when Supervisory and Low Battery condition are reported, and shows time of day when trouble calls are made.

Type: *STIME hh:mm* <enter>
where "hh" = 0 to 23
"mm" = 0 to 59

TIMEOUT - This command controls the length of time the sirens will sound when activated. (The timeout period is preset to 5 minutes.)

Type: *TIMEOUT STATUS* <enter> (or simply *TIMEOUT*) and the ITI Receiver will display the number of minutes the CPU's sirens will sound before timing out.

Type: *TIMEOUT nn* <enter>
where "n" = 1 to 15

TRAP - This command tells the Receiver which account number to trap upon receiving a call from that specific CPU. See Section 4.3 THE TRAP COMMAND or Section 4.5 REPROGRAMMING AN EXISTING PHONE NUMBER OR ACCOUNT NUMBER.

UPDATE - This command causes the Receiver to send all of the programming information in its memory to the CPU. This command should usually be followed by ERASE.

Type: *UPDATE* <enter> to update the CPU memory

XACCESS - Allows operator to set Access Code and Privilege Level of each of the extended multiple Access Code Users 11 through 33. See Section 4.7 SX-V ONLY COMMANDS.

ZONES - Gives listing of information for each sensor number programmed into CPU memory (Group Number, Letter Code, and other specific information). (Refer to Section 5.2 CENTRAL STATION MESSAGES DURING ZONE COMMAND.)

Type: *ZONES* <enter> for a complete listing of all zones in a CPU.

Type: *ZONE nn*<enter> to list one specific zone only.

Type: *ZONES nn NN* <enter> to list a shorter range of specific zones, where nn = the lower(beginning) number and NN = the higher (ending) number.

4.3 THE TRAP COMMAND

In order for a CPU to be "Trapped" when it calls the Receiver, the Central Station must first be programmed to trap that call by the TRAP command. When a call is "Trapped" it means the Receiver will put that call on hold and the Operator may perform Interactive programming commands on that particular CPU.

A trap **MUST** be placed at the Central Station **BEFORE** that account calls in. Up to 20 separate traps may be entered into Central Station at any one time. The TRAP command, when followed by an account number prepares the Central Station to put the account on hold when it calls into the Central Station. To TRAP account aa-aaa:

Type: *TRAP aa-aaa* <enter>.

By doing this you have told the Central Station to TRAP and hold on to Account aa-aaa.

When an account that matches a TRAP specification calls, the Central Station will print "Line n Trapped."

***The TRAP command shall not be used for U.L. listed systems providing home healthcare signaling service.*

NOTE: Account 00-000 is a permanent trap for an unprogrammed CPU. The Direct Programming (CPU) Jack on the front of the Receiver is always automatically trapped (unless suppressed by DEMOMODE command).

DIFFERENT FORMATS OF THE TRAP COMMAND

TRAP aa-aaa - Example: TRAP 12-345 will trap account number 12-345. Once this account has been trapped, then released, the trap specification will be removed.

WILDCARD TRAP - Example: TRAP 12-*** traps any account that begins with 12 since an asterisk is equal to any number or letter. This trap specification will stay on until removed.

TRAP aa-aaa OFF - Example: TRAP 12-345 OFF. This will remove the trap from account number 12-345.

WILDCARD TRAP OFF - Example: TRAP 12-34* OFF will remove the Wildcard Trap for any accounts beginning with 12-34.

TRAP OFF - This command will remove ALL traps except the trap on account 00-000 (an unprogrammed CPU).

NOTE: Any account that is trapped will stay on the line until it is released by the RELEASE command; or if there have been no commands for 15 minutes, the Central Station will automatically tell the CPU to release the line.

THE "TRAP ALL" COMMAND

The command, TRAP aa-aaa will trap only Account aa-aaa. TRAP ALL will trap any and all calls that come in. This command can be used to TRAP a CPU whose account number is unknown. Since this command will trap any and all calls--you only want to use it in special conditions.

WARNING: TRAP ALL will continue to trap all calls until it is set to off. Be sure to type **TRAP OFF** as soon as you are done using it.

Example:

Type: *TRAP ALL* <enter>
 Reply: **-***
 Ready

Type: *TRAP STATUS* <enter>
 Reply: **-***
 Ready

HOW TO TRAP AN ACCOUNT

Once a CPU has had a phone and account number programmed into its memory you *must* TRAP the account number in order to become Interactive with the CPU.

Example: If you want to trap ACCOUNT 12-345:

Type: *TRAP 12-345* <enter>.
 Reply: 00-000
 12-345
 Ready

Type: *TRAP STATUS*
 Reply: 00-000
 12-345
 Ready

To become Interactive the CPU must call the Receiver. This is usually accomplished by a Level 8 Phone Test at the CPU site. When the CPU calls, the Receiver will trap the account and become Interactive.

Type: *TRAP 12-345* <enter>
 00-000
 12-345
 Ready

Type: *TRAP STATUS* <enter>
 00-000
 12-345
 Ready

When call is received, the following message is displayed:

```
FRI MAR 15, 1987 10:49:57 #014
Account 12-345 Line 01
83 Phone Test
Protection Level Was 0 Now 8
Phone Test Complete
Line 01 Trapped
Line 01 Interactive
CPU is an SX-V
Ready
```

4.4 HOW TO PROGRAM AN UNPROGRAMMED CPU

PRELIMINARY CONSIDERATIONS

An ITI CPU calls the Receiver via a phone number that has been programmed into CPU memory so that it "knows" where to call when the CPU needs to communicate with the Receiver. The CPU is identified by a unique account number.

The CS-4000 Receiver is designed to allow the operator to program information into a CPU's memory using keyboard commands. These commands will instruct a CPU to dial the Central Station and give its account number along with alarms, trouble or test reports. The Receiver also allows the operator to make changes in the CPU's memory so they may customize it to specific requirements.

Since an unprogrammed ITI CPU has no phone number to dial or account number to report, it must be programmed with this information in order for the CPU to communicate with the receiver. This section explains the commands and procedures of programming such a CPU.

PROGRAMMING STEPS

An unprogrammed CPU has an Account number of 00-000. The Receiver has a permanent TRAP of Account 00-000.

To verify:

Type: *TRAP STATUS* <enter>
Reply: 00-000

This means you do not have to use the TRAP command for an unprogrammed CPU, it will be trapped automatically.

The following steps are the basic ones necessary to get the CPU programmed to communicate with the Central Station. In some instances additional programming will be done.

1. The Central Station operator calls the phone number on line which the CPU to be programmed is connected to using the Central Station Programming Telephone. The installer on site should answer on that line.
2. Once you are on the line with the installer have them put the CPU into phone test (Level 8). **Remind the installer not to hang up the telephone for at least 30 seconds so the CPU can seize the phone line.**
3. Listen for CPU line seizure (A click on the line).

4. Type: *ANSWER 1* <enter>.

NOTE: If the Receiver displays:

NO RESPONSE FROM CPU! LINE 01
LINE 01 RELEASED

Type: *ANSWER 1* <enter> again.

5. Wait approximately 10 seconds for the Central Station to establish communications and print the information. The Central Station prints this message when connections have been established:

Line 01 Trapped
Line 01 Interactive

6. Get privileged--the commands you will be using will require at least Low Level privilege.

Type: *PASSWORD n %pswd* <enter>
(where n is your operator number and %pswd is your password).

The Receiver will respond with acknowledgement of your Password Privilege.

7. Enter the CPU account number.

Type: *ACCOUNT aa-aaa* <enter>
(with "a" being either a number or letter).

In approximately 10 seconds READY will printout. The Receiver will respond with your previous account number 00-000 and below that the new account number aa-aaa.

8. Enter the phone number the CPU needs to dial to reach the Central Station Receiver:

Type: *PHONE nnnnnnnnnnnnnn* <enter>. (Up to 14 digits can be entered. D can be entered for a 3 second pause. D will count as a digit.)

-OR-

Enter phone number of Central Station using your pre-programmed phone number (from the PNUM command).

Type: *PHONE n* <enter>
("n" = PNUM A - J).

The Receiver will respond with the current phone number. In this case, instead of the current phone number, the Central Station will respond "phone number not initialized."

NOTE: If additional programming is required, refer to Section 4.2 INTERACTIVE COMMANDS THAT AFFECT A CPU. Do this before proceeding to the next step.

9. After all programming is complete, check your work.

Type: *UPDATE* <enter> In approximately 10 seconds
Reply: Ready READY will be displayed.

Type: *ERASE* <enter>

Reply: Ram Image Table Clear

10. Verify that your programming is correct by typing each command you used, followed by <enter>.

Type: *ACCOUNT* <enter> In approximately 10 seconds the
account number programmed into the CPU will be
displayed, followed by READY.

Type: *PHONE* <enter> In a few seconds the phone number
programmed into the CPU will be displayed, followed by
READY.

11. Check the accuracy of any other programming changes you have made at this time by the same method described in #10.

12. Release the CPU from the line and tell it to "hang up".

Type: *RELEASE* <enter> In approximately 15 seconds
LINE 01 RELEASED will be displayed.

NOTE: To get a condensed version of these steps on the screen of the CS-4000 :

Type: *HELP CPUPROG*<enter>

EXAMPLE

NOTE: THE COMMANDS THAT YOU TYPE ARE IN *ITALICS*.

ANSWER 1

Ready

FRI 13, 1987 11:42:36 #0015

Account 00-000 Line 01

83 Phone Test

Protection Level Was 0 Now 8

Phone Test Complete

Unprogrammed CPU

Line 01 Trapped

Line 01 Interactive

CPU is an SX-V

Ready

PASSWORD 2 %*****

Privilege Level is set to HI

Ready

ACCOUNT IT-001

Wait Until -Ready-

Account = 00-000

Account = IT-001

Ready

PHONE 6318205

Phone Number not initialized

6318205

Ready

or

PHONE n (with "n" being PNUM A,B,C...J)

Wait Until -Ready-

Phone Number not Initialized

6318205

Ready

UPDATE

Wait Until -Ready-

Ready

ERASE

Ram Image Table Cleared

Ready

ACCOUNT STATUS

Wait Until -Ready-

Account = IT-001

Ready

PHONE STATUS

6318205

Ready

RELEASE

Wait Until -Ready-

Line 01 Released

Ready

The previous example shows how an operator programmed an unprogrammed CPU. The operator entered the PHONE number, entered the ACCOUNT number, did an UPDATE of the CPU memory, entered ERASE to clear the Central Stations temporary memory, checked the ACCOUNT number, checked the PHONE number (to see if each was correct) and entered RELEASE to "hang up" the line. This is a typical example of programming a CPU correctly and checking your programming work. It is important to check your work.

COMMUNICATION VERIFICATION

Be sure to have the installer run a test signal into the receiver to verify proper system operation. The installer will do this by arming the CPU to Level 8, phone test.

IN CONCLUSION

Once you receive the PHONE TEST correctly you have completed programming the CPU. It is now "ON LINE" and will be sending you calls when necessary. Be sure to fill out the necessary documentation for record keeping and subscriber data.

DIRECT CPU PROGRAMMING

To program a CPU at the Receiver use the Programming CPU Jack on the front of the CS-4000. The programming jack accepts only the RJ31-X 8-position wide cord supplied with the CPU. The Receiver will automatically answer a CPU when a Level 8 phone test has been performed. If you do not want the receiver to automatically trap calls from the programming jack, the DEMOMODE command can turn this feature off.

PROCEDURE

1. Connect the RJ31-X Cord to programming jack of the Central Station.
2. Do a Level 8 phone test.
3. After 10 seconds you will become Interactive (Go to Step 5).
4. If you do not become Interactive, check your RJ31-X Cord wiring connections, clear the RAM and put in a sensor number and go to Step 2.
5. You may now program. Refer to the section HOW TO PROGRAM AN UNPROGRAMMED CPU.

NOTE: The Receiver automatically answers a call from a CPU connected to the Program CPU Jack located on the front of the Receiver.

The Receiver will also trap any call that comes in from a CPU that is connected to this jack. (You do not need to use the TRAP command.) This feature can be turned off by:

Type: *DEMOMODE ON* <enter> to make the CPU Jack stop automatically trapping the CPU.

WARNING! DO NOT CONNECT A LIVE PHONE LINE TO THIS JACK. Doing so will damage the Receiver.

This feature would be turned ON when the operator wants to display reports from a CPU that is plugged into the CPU jack without trapping each call. Turn this feature ON to display reports from a CPU plugged into the CPU jack without becoming interactive.

4.5 REPROGRAMMING AN EXISTING PHONE NUMBER OR ACCOUNT NUMBER

If it is necessary to change the phone or account number in a CPU that is not presently dialing the Central Station phone number or that has an incorrect phone or account number programmed into it, these are the steps to follow:

PROCEDURE WITH A KNOWN ACCOUNT NUMBER

****The TRAP command shall not be used for U.L. listed systems providing home healthcare signaling service.**

1. Trap the account number:

IF THE CPU IS AN SX-V
SEE HINT ON PAGE 56.

Type: *TRAP aa-aaa.*

2. Now *you* must call the site of the CPU on the programming phone line.
3. When the person answers, have a Level 8 phone test performed and tell that person to *stay* on the phone for at least 30 seconds.
4. When the phone test is initiated the line of the CPU will click and go dead. The CPU will begin dialing the phone number programmed in it.

DO NOT TYPE ANSWER 1 UNTIL THIS NUMBER HAS COMPLETED DIALING!

5. After you hear the CPU *complete* its dialing.:

Type: *ANSWER 1* <enter> (you are manually answering the CPU).

The display will show:

```
ANSWER 1
FRI MAR 6, 1987 20:00:00 #006
Account 12-345 Line 01
83 Phone Test
Protection Level Was 0 Now 8
Phone Test Complete
Line 01 Trapped
Line 01 Interactive
CPU is an SX-V
Ready
```

When you become Interactive go to Step 6.

NOTE: If you do not allow the CPU to complete dialing the phone number presently in the memory it will call that number and you will not become Interactive.

If display shows:

```
ANSWER 1
FRI MAR 6, 1987 20:00:00 #0015
NO RESPONSE FROM CPU! LINE 01
LINE 01 RELEASED
```

the line was not trapped. Re-enter your trap of the account number, call the installer and REPEAT the level 8 phone test initiated at the CPU.

NOTE: If you have tried this twice and have not become Interactive, you should inform the installer to clear the CPU's Ram memory. After the memory has been cleared, refer to HOW TO PROGRAM AN UNPROGRAMMED CPU.

6. Now that you are Interactive with the CPU you can change the PHONE/ACCOUNT number as needed. You can also perform any of the commands which interact with a CPU at this time. To change PHONE/ACCOUNT numbers refer to Steps 1-13 of the section HOW TO PROGRAM AN UNPROGRAMMED CPU. You must enter your Password to change any CPU programming.
7. After all programming is completed, enter the following commands to check your work.

Type: *UPDATE* <enter>

Type: *ERASE* <enter>

8. Verify your programming by entering each command you used.

For example:

Type: *PHONE* <enter> to verify that the phone number you entered is correct.

9. After you have checked your work and turned TRAP OFF, you may end Interactive programming by:

Type: *REL* <enter>.

PROCEDURE WITH AN UNKNOWN ACCOUNT NUMBER

Example: The CPU has a PHONE and ACCOUNT number other than yours programmed in its memory, and you want to put your phone number in its place. Since you do NOT know the account number you must use TRAP ALL in the following procedure:

1. CALL the technician at the CPU site.
2. Verify that this is the correct phone line.
3. Type: *TRAP ALL* <enter>.
4. Have the technician do a Level 8 phone test and have them *stay* on the phone for at least 30 seconds.
5. You will hear the line click when the CPU seizes the line.
6. Wait for the CPU to dial the phone number stored in its memory (you will hear it dialing).
7. When the CPU has finished dialing,
Type: *ANSWER 1* <enter>.

THE DISPLAY WILL READ:

TRAP ALL
 -
 Ready
ANSWER 1
 THUR MAR 12, 1987 16:52:21 #0010
 Account 12-345 Line 01
 83 Phone Test
 Protection Level Was 0 Now 8
 Phone Test Complete
 Line 01 Trapped
 Line 01 Interactive
 CPU is an SX-V
 Ready

WHEN YOU BECOME INTERACTIVE GO TO #9 :

But if you receive the response below,

ANSWER 1
 THUR MAR 12, 1987 16:53:50
 NO RESPONSE FROM CPU! LINE 01
 LINE 01 RELEASED

and you did *not* hear the CPU dial when the line went dead and you were cut-off, **repeat** the following procedure:

- a. Call the technician and make sure he did not hang up the telephone.
- b. If he did hang up, repeat the previous steps above and inform the technician to **STAY** on the telephone for at least 30 seconds.
- c. If he did not hang up the telephone for at least 30 seconds and he said the phone test was successful, the CPU RAM Memory must be cleared.
- d. After the memory has been cleared, refer to **PROGRAMMING AN UNPROGRAMMED CPU.**

9. You are now Interactive with the CPU.

Type: *TRAP OFF* <enter>

10. Enter your Password to become privileged to change the PHONE/ACCOUNT numbers.

Type: *PASSWORD n %pswd* <enter>

11. Change the PHONE and/or ACCOUNT numbers.

Type: *PHONE nn-nnnn* <enter> (up to 14 digits) **and/or**
 Type: *ACCOUNT aa-aaa*

12. If you are going to do any additional programming, do so at this time. (You may want to refer to Section 4.2 for definition of any commands.)

13. Update the CPU's memory.

Type: *UPDATE* <enter>

14. Erase temporary memory in the Central Station.

Type: *ERASE* <enter>.

15. Check your work by entering each command used.

Type: *PHONE STATUS* <enter> and/or
 Type: *ACCOUNT STATUS* <enter> to verify your work was correct.
 Type any other commands you may have used and verify.

If incorrect go back to #11 or #12.

16. Make sure you turned off TRAP ALL.

Type: *TRAP OFF* <enter>.

17. Release the line.

Type: *RELEASE*<enter>.

18. Verify TRAP OFF.

Type: *TRAP STATUS* <enter>
 Reply: 00-000

HINT ON TRAPPING A CPU WITH A PHONE NUMBER ALREADY IN MEMORY.

A CPU sometimes cannot be trapped using the method on pages 53-55, and the CPU may just cut off the phone line and try to dial the number in its memory. One suggested alternative is as follows:

1. Enter the TRAP command for the CPU. (Use TRAP ALL if you don't know the ACCOUNT number)
2. Call the installer on the programming telephone.
3. Tell the installer to do a Phone Test after the phone rings twice at the telephone to which the CPU is connected. Be sure to tell the installer not to answer the telephone!
4. Hang up and call the installer back.
5. Let the call ring until you hear line seizure.
6. After line seizure occurs, the CPU will begin dialing.
7. When the dialing is completed enter ANSWER 1.
8. If you do not become Interactive, repeat the process.
9. Type: *TRAP OFF*<enter>
10. Go to Step #10 on page 55.

4.6 THE GROUP COMMAND

The GROUP command is a powerful command used when the Central Station is Interactive with the CPU. The GROUP command allows a CPU to be tailored to the few applications where the power-up program is inadequate. Its primary function is in "borrowing" unused sensor numbers from one group for use in another. It may be used to change some characteristics of sensor numbers.

The behavior of each sensor in the various protection levels is determined by the GROUP NUMBER, and LETTER CODE assignments.

WARNING! BEFORE PROCEEDING WITH THE GROUP COMMAND, VERIFY WHICH TYPE OF CPU YOU ARE PROGRAMMING AS GROUP NUMBERS AND LETTER CODES DIFFER FOR THE SX-V, SX-IVB, AND SX-III/IVA SYSTEMS.

SX-V GROUP CODES

The Group Numbers and Letter Codes listed below are for use ONLY with the SX-V software. If the CPU you are programming is NOT an SX-V, refer to the SX-IVB or SX-III/SX-IVA Group Codes.

DESCRIPTION	SENSOR NUMBER	GROUP NUMBER	LETTER CODE	ACTIVE IN LEVELS
Alarm! Buddy System!	00	12	O	0-8
Bad Sensor Number ZZ	01	12	M	0-8
Unsupervised, Audible Panic	02-03	00	G	0-8
Unsupervised, Silent Panic	04-05	12	G	0-8
Supervised, Audible Panic	06	00	O	0-8
Supervised, Silent Panic	07	12	O	0-8
Unsupervised, Audible Medical Panic	10-11	01	G	0-8
Auxiliary (24 Hour)	12-17	01	P	0-8
Fire (24 Hour)	20-27	02	D	0-8
Special Intrusion	30-33	03	L	1-7
Exterior Delayed Intrusion	34-37	04	L	3-7
Exterior Instant Intrusion	40-57	05	L	3-7
Interior Intrusion Momentary	60-63	06	I	4-7
Interior Intrusion Momentary	64-65	07	I	4-5
Interior Intrusion Momentary Initiates Delay	66-67	09	I	4-7
Interior Intrusion	70-72	06	L	4-7
Interior Intrusion	73-74	07	L	4-5
Interior Intrusion Initiates Delay	75-76	09	L	4-7

BEHAVIOR OF LETTER CODES FOR THE SX-V

The behavior of each sensor in a particular protection level is determined by the sensor's Group Number and Letter Code. The Group Number determines the arming levels at which the sensor is active, the type of siren sound, whether or not it reports to the Central Station, and its delay/arming characteristics. The Letter Code determines how the CPU uses the sensor--as a door/window sensor (requiring a close signal) or a momentary device (no close signal)--and whether it is supervised by the CPU.

Letter (Attribute) Code	Characteristics	Typical Sensors
D	Supervised, has a battery, will send a close signal, will <i>NOT</i> prevent system from arming.	- ITI Smoke Detectors only
L	Supervised, no low battery detector, will send a close signal, can prevent arming of system (unless sensor is bypassed).	- Door/Window Sensors - Shock/Glasstracks with Door/Window Sensors
O	Supervised, no low battery detector, will <i>NOT</i> send a close signal, will <i>NOT</i> prevent system from arming.	- Momentary devices connected to Door/Window Sensor - Heat Detectors
I	Supervised, has a battery, will <i>NOT</i> send a close signal, will <i>NOT</i> prevent system from arming	- ITI D05984 PIR and Sound Sensors only
M	Unsupervised, no low battery detector, will <i>NOT</i> send a close signal, will <i>NOT</i> prevent system from arming.	- Pre-programmed alarm sensors
J	Unsupervised, no low battery detector, will send a close signal, can prevent arming of system.	- Tamper loop, Sensor #92
A	Does not have a low battery detector, normally closed sensor, not supervised does not send a close/restore signal to CPU.	
K	Does not have a low battery detector, normally closed sensor, supervised, does not send a close/restore signal to CPU.	
P	Does not have a low battery detector, normally closed sensor, supervised, will send a close/restore signal to CPU.	-ITI Freeze sensors
G	Unsupervised, has a battery, normally open, will not send a restoral	-ITI Panic Buttons

SX-IVB GROUP CODES

The Group Numbers and Letter Codes listed below are for the SX-IVB *only*.

DESCRIPTION	SENSOR NUMBER	GROUP NUMBER	LETTER CODE	ACTIVE IN LEVELS
Bad Sensor Number	01	12	M	0-8
Unsupervised, Audible Panic	02-03	00	G	0-8
Unsupervised, Silent Panic	04-05	12	G	0-8
Supervised, Audible Panic	06	00	I	0-8
Supervised, Silent Panic	07	12	I	0-8
Unsupervised, Audible Medical Panic	10-11	01	G	0-8
Auxiliary (24 Hour)	12-17	01	I	0-8
Fire (24 Hour)	20-27	02	D	0-8
Special Intrusion	30-33	03	E	1-7
Exterior Delayed Intrusion	34-37	04	E	3-7
Exterior Instant Intrusion	40-57	05	E	3-7
Interior Intrusion Momentary Armed 4-7	60-63	06	I	4-7
Interior Intrusion Momentary Armed 4-5	64-65	07	I	4-5
Interior Intrusion Momentary Armed 4-5 Initiates Delay	66-67	08	I	4-5
Interior Intrusion Armed 4-7	70-72	06	E	4-7
Interior Intrusion Armed 4-5	73-74	07	E	4-5
Interior Intrusion Armed 4-5	75-76	08	E	4-5

BEHAVIOR OF LETTER CODES FOR THE SX-IVB

Letter code	Characteristics	Typical Sensors
D	Supervised, has a battery, will send a close signal, will NOT prevent system from arming.	- Smoke Detectors - Heat Detectors
E	Supervised, has a battery, will send a close signal, can prevent arming of system (unless sensor is bypassed).	- Door/Window Sensors - Shock/Glasstracks with Door/Window Contacts
G	Unsupervised, has a battery, will NOT send a close signal, will NOT prevent system from arming.	- Portable Panic Buttons
I	Supervised, has a battery, will NOT send a close signal, will NOT prevent system from arming	- PIR, Sound Sensors, Pressure Mats and other Momentary Devices
M	Unsupervised, does not have a battery, will NOT send a close signal, will NOT prevent system from arming.	- Pre-programmed alarm sensors

SX-III AND SX-IVA GROUP CODES:

The Group Numbers and Letter Codes listed below are for the SX-III/IVA only.

DESCRIPTION	ZONE NUMBERS	GROUP NUMBER	LETTER CODE
Bad Sensor Number	01	11	A
Police Emergency (24 hour)	02-07	00	C
Medical Emergency (24 hour)	10-11	01	C
Auxiliary (24 hour)	12-17	01	C
Fire (24 hour)	20-27	02	D
Special Intrusion	30-33	03	E
Exterior Delayed Intrusion	34-37	04	E
Exterior Instant Intrusion	40-57	05	E
Interior Delayed Intrusion-Doors	60-62	06	E
Interior Delayed Intrusion-Motions	63-64	06	D
Interior Delayed Intrusion-Motions Disarmed in levels 6 & 7	65-67	07	D
Interior Instant Intrusion-Doors	70-73	08	E
Interior Instant Intrusion-Doors Disarmed in levels 6 & 7	74-76	09	E

BEHAVIOR OF LETTER CODES

In addition to the group number, a LETTER CODE (A through E) is used to indicate other zone (sensor) characteristics as follows:

- A - Unsupervised, momentary (does not send a "close" signal) and does not have a battery.
- B - Unsupervised, momentary (does not send a "close" signal) and has a battery.
- C - Supervised, momentary (does not send a "close" signal) and has a battery.
- D - Supervised, has a battery, will send a "close" signal, but will not prevent the system from arming.
- E - Supervised, has a battery, will send a "close" signal, and if open, can prevent the system from arming (unless the BYPASS key on the Wireless Keypad is used).

PREPROGRAMMED SENSOR NUMBERS

DESCRIPTION	SENSOR NUMBER	GROUP NUMBER	LETTER CODE	CPU TYPE*
Touchpad Low Battery	77	12	G	3,4,4B
Touchpad Tamper	77	12	G	5
Supervisory Unit n	77	12	G	5
Fire Buttons on Touchpad	80	02	M	4,4B
Fire Buttons on Touchpad	80	02	A	5
Police Buttons on Touchpad	81	00	M	4,4B
Police Buttons on Touchpad	81	00	A	5
Auxiliary Buttons on Touchpad	82	01	M	4,4B
Auxiliary Buttons on Touchpad	82	01	A	5
Phone Test	83	13	M	4,4B
Phone Test	83	13	A	5
Opening Report	84	14	M	4B
Opening Report	84	13	A	5
Closing Report	85	15	M	4B
Closing Report	85	13	A	5
Duress	86	12	M	3,4,4B
Duress	86	12	A	5
Force Armed	87	13	M	4B
Force Armed Auto	87	13	M	5
A/C Power Fail	90	13	M	4B
A/C Power Fail	90	13	J	5
CPU Low Battery	91	13	M	3,4,4B
CPU Low Battery	91	15	J	5
Tamper Loop	92	05	J	5
Weekly Phone Test	93	13	M	4B
Weekly Phone Test	93	13	J	5
Receiver Interference	94	13	J	5
Receiver Failure	94	13	J	5
CPU Back in Service	95	13	M	4B
CPU Back in Service	95	13	A	5
Failure to Communicate	96	11	M	4B
Failure to Communicate	96	11	A	5
Dialer Checksum Error	97	11	M	4B
No Phone Line	97	11	A	5

* CPU Type
 3=SX-III
 4=SX-IVA
 4B=SX-IVB
 5=SX-V

EXPLANATION AND PROCEDURE FOR THE GROUP COMMAND

The ITI alarm system is composed of a variety of optional sensor categories. An unprogrammed CPU may be referred to as a panel that has had the RAM memory cleared by an installer or technician. This means that the control panel (CPU) is set to the default characteristics. Therefore, the CPU sensors are grouped into the categories shown in the charts on the previous pages.

These categories cover a wide range of alarm protection. These categories include: Fire Sensors--Sensor Numbers 20 through 27, Exterior Delay Intrusion Doors--Sensor Numbers 34 through 37, Special Intrusion (such as gun cabinets, china closets, vaults etc.)--Sensor Numbers 30 through 33, to name a few.

Each type of CPU (SX-III/IVA, SX-IVB, or SX-V) has its own characteristics. Since the introduction of the first Interactive wireless system (SX-III) ITI's coding of the sensor characteristics has changed in order to improve technology such that the new SX-V possesses characteristics that represent the state-of-the-art in wireless technology.

The term "sensor characteristic" applies to two primary functions of the CPU:

1. The way the CPU (control panel) reacts when it receives a signal from a sensor.
2. How the CPU monitors the sensor's operation.

Breaking this down even further, each sensor category has been assigned a specific Group Number and Letter Code. These two items determine how the function of the sensor is treated by the CPU.

THE GROUP NUMBER

The Group Number determines how the CPU will react when it hears a signal from the sensor. This controls which siren output will occur, whether it calls the Central Station, and how it behaves during or initiates a delay (exterior delay intrusion category).

THE LETTER CODE

The Letter Code determines how the CPU will monitor the sensor. The CPU may be given the option of monitoring (or not) the following items: *Supervised, Monitor Battery Life, Send a Close Signal, Prevent the System from Arming, and Utilize the Tamper Feature.*

PROCEDURE OUTLINE

Each type of CPU has a specific set of Group Numbers and Letter Codes. Each type of ITI CPU has designated power-up values for sensor Group Numbers and Letter Codes. As an operator or installer, you will probably be asked to regroup some sensors at one time or another for installations requiring more sensors in a particular category than are available on a standard basis. You will need to borrow (or regroup) other sensor numbers from unused categories.

You *must* use the correct chart according to the model of CPU with which you are Interactive. The CPU type is always displayed by the CS-4000 once a call has been trapped.

It is important to verify what the installer wants to regroup before doing any programming. Be sure to ask the installer:

1. What type of CPU do they have.
2. What sensor numbers need to be regrouped.

Example:

I have an SX-IVB, and I want to change sensors 70 and 71 to the same category as sensors 40 through 57.

- a) Locate the SX-IVB CPU chart.
- b) Locate sensors "40-57."
- c) Find the Group Number and Letter Code for this category (05, E).
- d) Verify with the installer that the sensors to be regrouped are entered into CPU memory.
- e) Follow the example under HOW TO CHANGE THE GROUP OF A SENSOR.

THE GROUP COMMAND TAKES THIS FORMAT:

Group zz gg a

Where "zz" = a zone number, "gg" = a group number. and "a" = the letter code.

EXPANDING A GROUP

A typical use of the GROUP command would be in an installation in which ten fire detectors were needed. The power-up program only allows for eight detectors(20-27) so it will be necessary to change the characteristics of two others so they can be used for fire also. Fire detectors belong to group number 02, letter code D (See chart). Assuming you choose to change sensor numbers 16 and 17 so they become your new fire sensors, you must then change them so they also belong to group number 02, letter code D. To do this you would enter these two commands:

GROUP 16 02 D <enter> (Sensor 16, Group 2, Letter code D)
 GROUP 17 02 D <enter> (Sensor 17, Group 2, Letter code D)

Type: *ZONE nn* <enter> to check the change (with "nn" being a two digit zone number).

Example:

Type: *Zone 16* <enter>
 Reply: Ready
 Zone 16 Group 02-D
 Battery OK
 Received Today
 Closed or Clear

DEFINITION: When interactive, the CPU understands the command and prints the word ZONE when describing sensor or zone numbers. Zone and Sensor Number mean the same thing, but the Receiver only understands ZONE command.

HOW TO CHANGE THE GROUP OF A SENSOR

1. You must be Interactive with the CPU.
2. The GROUP COMMAND is a Low-Level command so you must enter your Password
3. Check to see if the sensor is INITIALIZED.

Type: *ZONE nn* <enter>

If the Response is: Zone Not Initialized,

Type: *INIT nn* <enter> to initialize that Zone.

If the sensor is initialized it will print out its sensor number and characteristics.

4. Determine the Group Number and Letter Code of the desired zones. When using GROUP COMMANDS look in the sensor number description column for the category of the desired sensor and follow across to the right to find the corresponding group number and letter code for that type of sensor.
5. Enter the GROUP COMMAND.

Type: *GROUP zz gg aa* <enter>
 (with "zz" = zone number,
 "gg" = group number and
 "a" = letter code.)

6. If you have more than 1 sensor to change go back to step 3.
7. Type: *UPDATE* <enter>
8. Type: *ERASE* <enter>
9. Check your work:

Type: *ZONE nn* <enter> for each sensor you have changed.

VERIFY THAT THE SENSOR NUMBER(S) YOU WANTED TO CHANGE HAVE THE CORRECT GROUP NUMBER AND LETTER CODE .

WARNING: Document any use of the GROUP command in detail. If a CPU loses both AC power and battery power it will power-up with the standard programming in place. All changes made previously with the GROUP command will be lost.

NOTE: If you are asked to initialize and/or regroup a number of sensors, refer to the MINITIALIZE and MGROUP commands at the end of this section. These two commands can save a lot of time and typing.

Example: (Remember commands you need to type are in italics.)

TRAP IT-001

00-000

IT-001

Ready

FRI MAR 6, 1987 10:43:30 #0013

Account IT-001 Line 01

83 Phone Test

Protection Level Was 0 Now 8

Phone Test Complete

Line 01 Trapped

Line 01 Interactive

CPU is an SX-V

Ready

PASSWORD 2 %*****

PRIVILEGE LEVEL is set to HI

Ready

ZONE 16

Wait Until -Ready-

Zone Not Initialized

Ready

INITIALIZE 16

Zone 16 Initialized

Ready

GROUP 16 02 D

Wait Until -Ready-

Zone 16 Group 01 - 0

Zone 16 Group 02 - D

Ready

UPDATE

Wait Until -Ready-

Ready

ERASE

Ram Image Table Cleared

Ready

ZONE 16

Wait Until -Ready-

Zone 16 Group 02 - D

Battery OK

Not Received Today

Closed or Clear

Ready

RELEASE

Wait Until -Ready-

Phone Test In Progress

Phone Test Complete

Line 01 Released

ADVANCED GROUP CHANGES

There are three commands which allow the operator to make changes to a CPU program where large groups of sensors are involved. These commands are MGROUP, MINTIALIZE, and MDELETE. By using these commands the operator has the ability to initialize, delete and regroup large sections of consecutive sensors with a single command.

MGROUP COMMAND

In some applications there may be a need to change many Sensor Numbers to the same Group Number and Letter Code. Large fire systems are a good example of the use of the multiple grouping command, MGROUP. With the MGROUP command, groups of consecutive sensor numbers may be assigned to the same group number and letter code.

To use the MGROUP command:

Type: *MGROUP nn NN gg LL*<enter>

Where "nn" = the beginning (lower) number in the range of sensor numbers,
 "NN" = the ending (higher) number in the range of sensor numbers,
 "gg" = the group number,
 "LL" = the letter code.

PROCEDURE

1. Check to see that all sensors in the range of a zone number have been initialized.

Type: *ZONE nn NN* <enter>

2. Initialize any missing zones.

Type: *INITIALIZE nn* <enter>

3. Determine Group Number and Letter Code from the chart.

4. Use the MGROUP command to change the Group Number and Letter Code of a range of consecutive sensor numbers.

Type: *MGROUP nn NN gg LL* <enter>

Type: *UPDATE* <enter>

Type: *ERASE* <enter>

5. Check your work:

Type: *ZONE nn NN* <enter>

6. If the programming is correct the task is finished.

Example:

A large fire system needs to be programmed. Sensors 20-27 have been used and eight more are needed. Sensors 10-17 are selected to be the eight additional sensors. Since fire sensors belong to Group Number 02 and Letter Code D, these additional sensors may be coded as fire sensors by entering the following command.

```
Type: MGROUP 10 17 02 D <enter>.
Reply: Zone 10 02 D
       Zone 11 02 D
       Zone 12 02 D
       Zone 13 02 D
       Zone 14 02 D
       Zone 15 02 D
       Zone 16 02 D
       Zone 17 02 D
```

MINITIALIZE COMMAND

This command allows the operator to initialize a group of consecutive sensor numbers. This command could be used in conjunction with the MGROUP command when doing large group changes. When entered, the MINITIALIZE command initializes all consecutive sensor numbers in a range as designated in the command.

To use the MINITIALIZE command:

```
Type: MINITIALIZE nn NN <enter>
where "nn" = beginning (lower) number
and "NN" = ending (higher) number
```

Example:

You want to regroup sensors 10 to 17 for a fire system in an unprogrammed CPU. In this example, sensor numbers 10 through 17 have not been initialized by the installer, so you will have to initialize these sensors before performing the GROUP command.

```
Type: MINITIALIZE 10 17 <enter>
Reply: Zone 10 Initialized
       Zone 11 Initialized
       Zone 12 Initialized
       Zone 13 Initialized
       Zone 14 Initialized
       Zone 15 Initialized
       Zone 16 Initialized
       Zone 17 Initialized
```

Now all sensors 10 through 17 are initialized and you may perform the GROUP change.

```
Type: MGROUP 10 17 02 D <enter>
Reply: Zone 10 02 D
       Zone 11 02 D
       Zone 12 02 D
       Zone 13 02 D
       Zone 14 02 D
       Zone 15 02 D
       Zone 16 02 D
       Zone 17 02 D
```

MDELETE COMMAND

This command allows the operator to delete a group of consecutive sensor numbers. This command would be used when a group of sensors have been programmed into CPU memory, but are not now needed.

To use the MDELETE command:

```
Type: MDELETE nn NN <enter>
       where "nn" = beginning (lower) number
       and "NN" = ending (higher) number.
```

Example:

You want to delete Sensors 10 through 17.

```
Type: MDELETE 10 17 <enter>
Reply: Zone 10 deleted
       Zone 11 deleted
       Zone 12 deleted
       Zone 13 deleted
       Zone 14 deleted
       Zone 15 deleted
       Zone 16 deleted
       Zone 17 deleted
```

EXAMPLE OF GROUP CHANGES FOR THE SX-V.**Example 1: REGROUPING MOMENTARY DEVICES CONNECTED TO DOOR/WINDOW SENSORS**

There will be instances when a customer will want to connect various momentary devices (PIR's, sound sensors, pressure mats, heat detectors, freeze detectors, etc.) to an SX-V Door/Window sensor. It is important to determine, by asking the customer, whether or not the unit connected to the Door/Window sensor is a momentary device.

Why? Refer to BEHAVIOR OF LETTER CODES FOR THE SX-V.

- 1) Letter Code L is for a door or window that opens and closes.
- 2) Letter Code I is for an ITI PIR or Sound Sensor *only*.
- 3) Letter Code D is for an ITI Smoke Detector *only*.
- 4) Letter Code O is for a momentary device connected to an SX-V door/window sensor.

Letter Code O has been designed to allow the connection of a momentary device to an SX-V door/window sensor. The reason Letter Code I will not work is that it has a battery that is monitored by the CPU. If you read the description for Letter Code O (used for momentary devices) you will notice there is no battery detector. If Letter Code I were used, it would result in Low Battery reports from that sensor.

In this example we assume that the installer wants Zone Number 60 to be a sound discriminator connected to a door/window sensor. Looking at the Group Number and Letter Code for Zone 60, you find 06, I. Letter Code O needs to be substituted for I in this example.

The sensor in the 60-63 category has a Letter Code I. We do not want to use I in this example as it only applies to ITI PIR's and Sound Sensors. The correct Letter Code would be O.

The command would be:

Type: *GROUP 60 06 O* <enter>

EXAMPLES OF GROUP CHANGES TO THE SX-IVB

Example 1: YOU NEED MORE EXTERIOR INSTANT ZONES

The SX-IVB powers up with a total of 17 Exterior Instant Zone Numbers. In the case of a large installation, the installation company may request that you regroup other sensor numbers for their additional zones. In this example, the installers need two more Exterior Instant Zones. They have chosen sensor numbers 70 and 71 to be regrouped to Exterior Instant Zones. First, you look at the SX-IVB Chart to determine your Group Number and Letter Code of an Exterior Instant Zone which is 05 E. Since Zones 70 and 71 are Interior Intrusion Zones grouped 06 E, we must change their group to match Exterior Instant Zones by:

Type: *GROUP 70 05 E*<enter>
GROUP 71 05 3 <enter>

Example 2: SOUND SENSOR

Sound Sensors (also referred to as Audio Detectors or Audio Discriminators) are sometimes used in installations that also have PIR's. In this example, we will assume that all eight sensor numbers (60-67) have been used for PIR's and the customer also has 4 Sound Sensors to be installed. Normally a sound sensor would have a 60 category, since it is a momentary device. Since that category is full as mentioned earlier, the customer chooses Zones 54 to 57 for the sound sensors. Since Zones 54 to 57 are the group to act as a door or window (requires a close signal) the sound sensors must be regrouped as it is a momentary device which does not send a close signal. If a sound sensor was programmed in the CPU as an Exterior Instant Zone (40 to 57) and not regrouped as a momentary device (Letter Code I), the customer would possibly complain of arming (protest) problems from those sound sensors.

In this example, the customer wants the Sound Sensors to be regrouped in the Interior Instant Momentary 4-7 Group.

Type: *GROUP 54 06 I* <enter>
GROUP 55 06 I <enter>
GROUP 56 06 I <enter>
GROUP 57 06 I <enter>

Example 3: MAKING POLICE PANIC BUTTONS ON TOUCHPAD SILENT

There are instances when a customer wants to make the police buttons on the Touchpad silent. Normally pressing both police buttons will sound the interior and exterior sirens. The police buttons have been pre-programmed to Sensor Number 80. In this example the customer wants the police buttons silent. Determine the correct Group Code from the chart for the SXIVB and find the Unsupervised Silent Panic category. This category has a Group Number of 12 which makes it silent. The Letter Code G would not be used in this case since it is for a Portable Panic Button. You would leave it with a Letter Code of M as Sensor Number 80 is a pre-programmed Sensor Number. Using Group Number 12 and Letter Code M:

Type: *GROUP 80 12 M* <enter>

4.7 SX-V ONLY COMMANDS

The following commands will only work with the SX-V CPU's. They will not work with the SX-III, SX-IVA, or SX-IVB CPU's.

DEFINITIONS

The following commands are used to communicate with the CPU. Each command is defined and an example given of how it would be entered into the CPU. The commands defined in this section include:

BUDDY	CTIME	LEVEL
OPTION	DIALBACK	MACCESS
CPUTIME	EVENT	PTFREQ
	IDBUFFER	XACCESS

For certain commands listed above, the Receiver will print not only the change you have made, but a complete listing of all options for the command. To instruct the Receiver to suppress this automatic status listing for these commands type a space and the plus sign (+) after the command before pressing the <enter>. This will cause only the change you have made to be displayed (and printed). This is true for CHANNEL, LEVEL, MACCESS, OPTION, and XACCESS commands.

Example: LEVEL 1 ON + <enter>
CHANNEL 2 DISRREQ OFF + <enter>

Hint: Remember to use the <F5> key to save time and typing when doing multiple changes with those commands.

BUDDY SYSTEM - This feature allows a neighboring CPU to call in a "Alarm! Buddy System" from a CPU that is unable to dial out to the Central Station. An SX-V CPU can be a BUDDY to as many as four different dependent SX-V CPU's. Each dependent CPU will have a transmitter programmed to Zone 00 connected to its "Fail To Communicate" output. This feature is activated only on alarm calls--not trouble calls (e.g.. Supervisory, Low Battery).

In the event a phone line fails *and* an alarm condition occurs at the same time, the dependent CPU will not be able to call the Central Station and will activate a Sensor you have programmed to send Zone 00. A Buddy CPU stores the Account Number and House Codes of the dependent CPU's it is monitoring, and when the Buddy CPU receives the 00 signal from one of those CPU's, it will call the Central Station and report a 00 Alarm! Buddy System message along with the account number of the dependent CPU. Each SX-V CPU may be a BUDDY to four other CPU's. Each dependent CPU may be a BUDDY to four other CPU's including the original Buddy CPU.

Type: *BUDDY n aa-aaa hhh* <enter>,
where "n" = dependent CPU number (1 through 4),
"aa-aaa" = dependent CPU account number, and
"hhh" = dependent CPU house code.

NOTE: The BUDDY CPU supervises the dependent CPU's transmitter (#00) and vice versa. If you receive a "00 Supervisory" it will be from one of the dependent CPU's. The Buddy number will be displayed along with the Supervisory message.

CPUTIME - Sets the CPU time/date to the Receiver time/date.

Type: *CPUTIME SET* <enter> for the Receiver to set the SX-V clock.

CTIME - Causes the display of CPU's clock at end of each report:

Type: *CTIME ON* <enter>

Type: *CTIME OFF* <enter> to turn off the clock display function.

Type: *CTIME ALL* <enter>.

NOTE: If set to ALL, any SX-V CPU that calls in will have its clock-calendar updated to the Central Station date/time. (Any uninitialized CPU will automatically have its date/time set regardless of how this command is set.) In general, use of this option is recommended to keep the SX-V clocks up to date as the clock may be off due to a power loss.

DIALBACK - Instructs the CPU to call back the Central Station in "mmm" minutes with an 83 Phone Test where "mmm" = 1 to 255 min.:

Type: *DIALBACK mmm* <enter>

EVENT - This command is used to call up events stored in the SX-V CPU Event Buffer. Stored events include: Alarm!, Cancel, Supervisory, Low Battery, Trouble, Opening/Closing Report, Protection Level change etc. Events are listed in chronological order with the most recently-occurring event listed first.

The event buffer stores up to 64 events. The most recent event will be displayed first. To view the last n events, n = 1-64:

Type: *EVENT ALL* <enter> to display all events

Type: *EVENT n* <enter> to display the last "n" events,

Type: *EVENT CLEAR* <enter> to clear the event buffer.

IDBUFFER - This command is used to call up the House Codes that an SX-V has stored in its ID buffer memory. The SX-V will store the House Code of any SX-V within its range. The installer should be informed of these House Code numbers, so that two sites in the same range do not have the same House Code number.

Type: *IDBUFFER* <enter> to display all house codes.

Type: *IDBUFFER CLEAR* <enter> to clear CPU buffer memory.

NOTE: The EVENT and IDBUFFER are very slow commands, and it may appear that nothing is happening. Wait until READY appears on the display screen. To interrupt this process press the <ESC> key.

LEVEL - This command controls the ten arming levels of the CPU. For example, you might want to have only Level 0 (Disarm) and Level 4 (Away) armable in a commercial system. You could then disable 1-3 and 5-7. See Appendix D.

Type: *LEVEL STATUS* <enter>

(or simply LEVEL) to display the ten arming levels of the CPU and whether each is "armable" or "disabled".

Type: *LEVEL n ON* <enter> to enable the CPU to be armed to Level n, "n" = a number between 0-9 by a LOW or HI Level Access Code User.

Type: *LEVEL n OFF* <enter> to disable the CPU so it cannot be armed to Level "n" arming level

Type: *LEVEL n RESTRICT*
 In the SX-V CPU, multi-users can be restricted from using certain levels of protection. The two protection levels are Low and Hi.

By using *LEVEL n RESTRICT*, Low Level CPU users are restricted from arming to "n" Level. The SX-V access codes (a maximum of ten) can be set to a Low or Hi privilege level. (Refer to *MACCESS* and *XACCESS* command below.) The *LEVEL*, *MACCESS* and *XACCESS* commands can work together to set up restrictions for a multi-user system. The Hi Level privileged access code users can use all levels, and the Low Level privileged access code users cannot use any level that is restricted.

MACCESS - Allows you to set the Access Code and Privilege Level of each of the Multiple Access Code Users 1 through 10; also identifies which user initiated opening or closing report.

NOTE: User 1 is always the "LOW" Privilege level (it is the customer's temporary "babysitter" code that can be set by the customer on site) and User 2 is always the "HI" Privilege level, regardless of how you try to set them.

Type: *MACCESS n HI dddd* <enter>
 where n = user number 1 through 10, dddd = access code, to assign a HI privilege level to user n with Access Code dddd

Type: *MACCESS n LOW dddd* <enter>
 to assign user "n" with access code "dddd" a LOW privilege level.

Note 2: No test is made to see that these Access Codes differ from the Primary Access Code or the Duress Code.

Example:

01	LOW	4321	(Secondary Access Code 01 is always LOW)
02	HI	5432	(Always HI)
03	LOW/HI	dddd	(Users numbers 3 through 10 can be set LOW or HI)
10	LOW/HI	dddd	

Levels 0, 8, and 9 power up as restricted on an unprogrammed SX-V CPU.

OPTION - This command allows you to set the SX-V CPU "F" options. (Refer to the SX-V Chart on next page.)

Type: *OPTION Fxx ON* <enter>
 where "xx" = 00 to 07 or 10 to 17.

Type: *OPTION Fxx OFF* <enter> to turn option "xx" off.

PTFREQ - This command causes the CPU to automatically call in every "n" days. Remember--Phone Test Frequency.

Type: *PTFREQ n N* <enter>
 where "n" = length of days in cycle (1 to 255)
 "N" = days remaining in cycle (must be equal or less than n).

XACCESS - This command sets the Extended Access Codes 11 through 33 inclusive. It is valid for SX-V CPU software dated 4/18/88 or later *only!*

NOTE: XACCESS Code Users 11 through 33 are LOW Level Multiple Access Code users only. They cannot be set to a HI Level privilege.

Type: *XACCESS uu aaaa* <enter>
 where "uu" = user number 11 through 33
 "aaaa" = access code desired.

SENSOR NUMBER CHART

SENSOR NUMBER	SENSOR TYPE	ACTIVE LEVELS	SUPER-VISED	SIREN SOUND
01	Bad Sensor Number	0 - 8	No	Silent
02 - 03	Police Panic	0 - 8	No	Loud Intermittent
04 - 05	Police Panic	0 - 8	No	Silent
06	Police Panic	0 - 8	Yes	Loud Intermittent
07	Police Panic	0 - 8	Yes	Silent
10 - 11	Medical Panic	0 - 8	No	Low Level Beeping
12 - 17	Environmental (Flood, Freeze, etc.)	0 - 8	Yes	Low Level Beeping
20 - 27	Fire Sensors	0 - 8	Yes	Loud Steady Tone
30 - 33	Special Intrusion (Gun Cabinets, Safe, Etc)	1 - 7	Yes	Loud Intermittent
34 - 37	Delayed Entrance Intrusion (Entry Doors)	3 - 7	Yes	Loud Intermittent
40 - 47	Instant Exterior Intrusion (Windows)	3 - 7	Yes	Loud Intermittent
50 - 57	Instant Exterior Intrusion (Windows)	3 - 7	Yes	Loud Intermittent
60 - 63	Instant Interior Intrusion (Momentary Device) ¹	4 - 7	Yes	Loud Intermittent
64 - 65	Instant Interior Intrusion (Momentary Device) ¹	4 - 5	Yes	Loud Intermittent
66 - 67	Delayed Interior Intrusion (Momentary Device) ²	4 - 7	Yes	Loud Intermittent
70 - 72	Instant Interior Intrusion (Interior Doors, cabinets, etc) ¹	4 - 7	Yes	Loud Intermittent
73 - 74	Instant Interior Intrusion (Interior Doors, cabinets, etc) ¹	4 - 5	Yes	Loud Intermittent
75 - 76	Delayed Interior Intrusion (Interior Doors, etc) ²	4 - 7	Yes	Loud Intermittent
80,81,82,etc	Preprogrammed Sensor Numbers. See Note 3 below.			

OPTIONAL SENSOR NUMBERS

SENSOR NUMBER	PURPOSE	DESCRIPTION
00	Buddy System	Refer to SX-V Installation Manual.
84	Opening Report	If the CPU is disarmed a opening report is sent to the central station.
85	Closing Report	If the CPU is armed a closing report is sent to the central station.
87	Forced Armed	If CPU is armed with a sensor bypassed a forced armed report is sent.
90	A/C Failure	If the CPU loses AC for over 15 minutes a report is sent to the C.S.
92	CPU Tamper	Enter 92 if CPU tamper loop is to be used. See Optional Feature F01 below.
93	Automatic Test	Refer to SX-V Installation Manual.

OPTIONAL FEATURES

FEATURE NUMBER	PURPOSE	DESCRIPTION
F00	Exit delay sounds	Set to have exit delay beeps sound throughout delay time, instead of once.
F01	Tamper Polarity.	CPU tamper loop is N.C. Set to change it to N.O. See also sensor 92 above.
F02	Exterior Siren Delay	Set if you want the exterior siren sounds to delay for 15 seconds.
F03	Local Alarm	Set if this is a local alarm and is <i>not</i> to report to the central station.
F04	Low Battery Report	Low batteries normally report weekly. Set if they are not to report at all.
F05	Supervisory Report	Supervisor reports normally report daily. Set if they are to report weekly.
F06	Dialer Abort	CPU normally reports Violations and Cancels. Set for Violation reports only.
F07	Open Sensor Display	Set if you want open sensors displayed when CPU is in Levels 0, 1 and 2.
F10	Dealer Sensor Test	Set and next Sensor Test will sound one beep for each sensor round received.
F11	Interior Siren Sounds	Set if hardwire interior sirens should sound alarms only, not status beeps.
F12	Restoral Reporting	Set if you want violations to send a Restoral report when the sensor is closed.
F13	Not used	
F14	Hourly Phone Test	Sounds trouble beeps & displays 97 if phone line is dead at time of hourly test.
F15	Sensor Tamper	Normally left off. See SX-V Installation Manual.
F16	Trouble Beeps	Set if Trouble Beeps sound only for Fire Sensors.
F17	Direct Bypass Toggle	Set if you wish customer to be able to directly unby pass bypassed sensors.

Note 1 Sensors 60 - 65 and 70 - 74 are instant zones, however they will honor a delay initiated by a delayed sensor.

Note 2 Sensors 66 - 67 and 75 - 76 initiate a delay just like an entrance door.

Note 3 See Installation Manual for description of all the Preprogrammed Sensors.

SECTION 5 CENTRAL STATION MESSAGES

5.1 EXAMPLES OF CENTRAL STATION REPORTS

Monitoring alarms on the ITI Central Station is very similar to working with other digital receivers, with two exceptions:

- 1) The System is user friendly--display is in English.
- 2) There are more zones (referred to as Zone Numbers or Sensor Numbers) so more detailed information is available regarding the exact location of the alarm.

WHAT HAPPENS WHEN AN ALARM IS RECEIVED---

1. The Central Station will make a "beeping" sound.
2. Push SILENCE button.
3. Alarm information will print out if you have a printer connected to the CS-4000.
4. Alarm information will also show on the Central Station CRT.
5. Respond to alarm as usual.
6. Push CLEAR button to acknowledge that proper actions were taken.

See the Section CENTRAL STATION MESSAGES DURING AN ALARM for a complete listing and definition of Central Station messages during an alarm.

TYPICAL ALARM REPORTS

This is a typical report:

FRI MAR 6, 1987 11:47:58 #0002	<---Date, Time and Report Number
Account BC-123 Line 01	<---Account Number and Phone Line Number
34 Alarm!	<---Zone Number & condition
Protection Level Was 4 Now 0	<---Ignore
Line 01 Released	<---Phone Line released, call completed

You are concerned only about:

(1) ACCOUNT NUMBER:	BC-123
(2) ZONE	34
(3) CONDITION	Alarm!

In the above example, Zone 34 is in alarm for customer account BC-123. Refer to that customer's data card and dispatch as normal.

TUES MAR 17, 1987 21:25:50 #0026	<---Date, Time and Report number
Account 55-150 Line 01	<---Customer Account # and Phone Line #
40 Supervisory	<---Zone number & Condition
Protection Level was 0 Now 0	<---Ignore
Line 01 Released	<---Phone Line released, call completed.

In the above example Zone 40 is in a supervisory condition. Refer to Service Manual.

TUES MAR 17, 1987 22:25:50 #0027 <—Date, Time and Report number
 Account 55-150 Line 01 <—Customer Account # and Phone line #
 60 Low Battery <—Zone number & Condition
 Protection level was 0 Now 0 <—Ignore
 Line 01 Released <—Phone Line released, call completed.

In the above example Zone 60 is reporting a low battery. Refer to Service Manual.

 ALARM REPORT IS RECEIVED AND CANCELLED IN SAME CALL

SAT MAR 07,1987 #0008
 Account 10-719 Line 01 <—Account: 10-729
 64 Alarm! <—Zone 64 in Alarm
 64 Cancelled <—Zone 64 cancelled
 Protection Level Was 4 Now 0
 Line 01 Released

In this example, Zone 64 was in alarm but then CANCELLED for Account 10-729. You typically would not dispatch the authorities. You might, however, call your customer to see if they have any questions or problems.

 CUSTOMER CANCELS AFTER 2 MINUTES

SUN MAR 08,1987 12:29:17 #0008 <—12:29 pm
 Account 10-591 Line 01 <—Account: 10-591
 34 Alarm! <—Alarm for zone 34
 Protection Level Was 0 Now 4
 Line 01 Released

On this example, Zone 34 was in alarm for account 10-591. You would dispatch. Then one or two minutes later you receive this:

SUN MAR 08, 1987 12:31:15 #0009 <—12:31 pm - two minutes later
 Account 10-591 Line 01 <—Account: 10-591
 34 Cancelled <—Alarm for Zone 34 is cancelled
 Protection Level Was 4 Now 0
 Line 01 Released

The customer (Account 10-591) has CANCELLED the alarm. Since only your customer can cancel an alarm, you could call and cancel the authorities. You might want to call your customer first, to be sure they were not forced to disarm the system. Some companies chose not to cancel the authorities unless the cancelled report is received in the same phone call as the alarm. Follow the procedures your company has established.

TWO ALARMS ARE RECEIVED IN SAME CALL

MON MAR 09, 1987 03:08:12 #0012

Account SX-510 Line 01

34 Alarm!

52 Alarm!

Protection Level Was 2 Now 7

Set 10 days 12 Hrs 48 Min Ago

Line 01 Released

<—Account SX-510

<—Alarm for Zone 34

<—Alarm for Zone 52

<—This message appears if PTIME
feature is On and a non-cancelled
alarm reports in.

In this example, two zones are violated: Zone 34 and Zone 52.

A WRONG NUMBER

THU MAR 12, 1987 16:38:14 #0008

No Response from CPU! Line 01

Line 01 Released

No response is necessary. This is an example of what happens when a wrong number is dialed and someone gets the Central Station by accident.

LOW BATTERY REPORT

SUN MAR 08, 1987 03:08:51 #0007

Account SX-501 Line 01

70 Low Battery

Protection Level Was 2 Now 7

Line 01 Released

<—Account SX-501

<—Zone 70 has a low battery

Refer this account to service to replace the low battery.

SUPERVISORY REPORT

WED NOV 19, 1986 03:19:30 #0015

Account SX-502 Line 01

21 Supervisory

64 Supervisory

35 Supervisory

Protection Level Was 0 Now 7

Line 01 Released

<—Account SX-502

<—Zone numbers 21, 64 and 35 all
experiencing supervisory problems

Refer this account to service.

SILENT ALARM

FRI MAR 06, 1987 10:37:34 #0029

Account 02-709 Line 01

40 Alarm!

63 Alarm!

Protection Level Was 0 Now 5

Line 01 Released

<—Account 02-709

<—Zones 40 and 63 have been tripped

<—Protection Level 5 intrusion alarm.

In this example the alarm is silent at the break-in site. You know this because the CPU is armed to Level 5, which is silent. Also, sensor 40 and 63 are burglary sensor numbers.

A CALL WHICH MADE 2 CALLS TO REACH THE CENTRAL STATION

THU MAR 12, 1987 21:05:58 #0009

GARBLED DATA!

40 Alarm!

40 Cancelled

Protection Level Was 3 Now 0

Line 01 Released

<—First connection at 21:08:51

<—The CPU data was not transmitting clearly to the Central Station

THU MAR 12, 1987 21:08:10 #0010

Account 06-107 Line 01

40 Alarm!

40 Cancelled

Protection Level Was 3 Now 0

Line 01 Released

<—Second attempt at 21:08:10

<—Account 06-107

<—Zone 40 was in alarm and cancelled in the same call.

<—The call came in "clean" on the second attempt.

In this example the CPU called the Central Station and the Central Station answered. However, the data was garbled and contained errors. The Central Station will have the CPU hang up and call back immediately in order to get the call through.

PHONE TEST (AUTOMATIC TEST FEATURE ON)

THU MAR 12, 1987 16:36:00 #0230

Account SX-506 Line 01

83 Phone Test

Protection Level Was 0 Now 8

Phone Test Complete

Line 01 Released

<—Account SX-506

<—Zone 83 phone test indicates CPU communications test

<—The Central Station is causing the subscriber's CPU to make each of its alarm sounds for 2 seconds.

PHONE TEST (AUTOMATIC TEST FEATURE OFF)

SUN MAR 08, 1987 22:09:09 #0150

Account SX-508 Line 02

83 Phone Test

Protection Level Was 0 Now 8

Line 02 Released

<— Account SX-508

<— Zone 83 phone test indicates CPU
communications test

Account #06-12R has actuated a CPU test call to the Central Station by pressing their Access Code + 8. If the Central Station is set up with the TEST feature OFF, the customer will require a telephone call to acknowledge receipt of the test.

EXIT FAULT

SUN MAR 08, 1987 07:09:14 #0028

Account SX-532 Line 03

34 Exit Fault

34 Cancelled

Protection Level Was 4 Now 0

Line 03 Released

<— Account SX-532

<— Zone 34 Exit Fault

<— Zone 34 Cancelled

In this example the subscriber did not get his delay entry/exit door (Zone #34) closed until after the exit delay time was complete. This is NOT an intrusion. This customer realized his mistake when the alarm sounded and he cancelled the alarm immediately.

NOTE: All exit faults will not necessarily come in with a cancellation report.

AUTOMATIC PHONE TEST

FRI MAR 06, 1987 19:11:24 #0222

Account SX-504 Line 01

93 Automatic Phone Test

Level Was 0 Now 6

Line 01 Released

<— Account SX-504

<— Automatic Phone Test

Automatic phone tests are typically sent to central stations that are computerized on a daily, weekly or monthly basis. The computer is set to flag all accounts that miss this test.

5.2 CENTRAL STATION MESSAGES DURING ALARM

These are examples of messages which can be displayed and printed when an alarm call has been received. Each line item is explained as you may get more than one message in a given alarm call.

NOTE:	n = any number
	zz = two digit sensor or zone number
	a = any number or letter

MESSAGES DURING ALARM

Account aa-aaa Line n

There is an incoming call on CPU Phone line (1,2,3, or 4) and Account Number aa-aaa.

Protection Level was n now n

Indicates previous and current protection levels.

zz Alarm!

Indicates a zone in an alarm condition. This generally requires operator attention unless it is followed by CANCELLED.

zz Alarm! Tamper

Indicates the zone has been tampered with. This alarm occurs when a cover is taken off an SX-V door/window transmitter (The F15 feature in the SX-V CPU must be initialized.)

zz Cancelled

The customer cancelled the alarm by changing the protection level. In some cases procedures may require a response by the Central Station operator. This message will be highlighted and flash.

zz Restoral (SX-V only)

The F12 Option is initialized in this CPU and this message says that this sensor has been restored to normal condition.

zz Supervisory

The indicated sensor has not successfully transmitted any signals for 24 hours (12 hours for the SX-V) and requires service. This is not an alarm. (Refer to service department. Do not dispatch!)

zz Low Battery

The battery in the indicated sensor needs to be replaced. (Refer to service department. Do not dispatch!)

zz Exit Fault

The indicated exit door was not closed when the exit delay time expired.

Line n Released

The call is completed.

Line n Trapped**Line n Interactive**

The call was selected for Interactive work with the TRAP command. Message will be highlighted and flash. You may begin programming.

Test in Progress

The Central Station is causing the CPU to generate each of its alarm sounds for two seconds. This occurs when the TEST feature is ON and a Zone 83 Phone Test is received.

Phone Test Complete

The CPU's phone test was successful and is now completed.

Access Code used nn days, hh hours, mm minutes Ago

If the PTIME option is ON, and a call was received that included an uncanceled violation, the time shown is the last time the customer used the access code to change the protection level of the system. The time is in terms of local Central Station time or whatever time zone the Central Station is set for. It is not necessarily the customer's time zone.

CAUTION: IF THE ACCESS CODE HAS NOT BEEN USED WITHIN THE LAST 15 DAYS, THE NUMBER OF DAYS SHOWN WILL BE WRONG, AND WILL BE A NUMBER BETWEEN 0 AND 15. Therefore, the customer should advise Central Station personnel if he is going on a vacation for more than two weeks.

00 Alarm! Buddy System! (SX-V CPU only.)

This indicates that there has been *both* a phone line failure and an alarm condition at the account displayed.

01 Bad Sensor Number zz (SX-V CPU only)

The CPU has just heard from a sensor (zone) that has the correct House Code but is not initialized in the CPU's memory. This applies to SX-V only. This is not an alarm, refer to service.

77 Supervisory Unit n (SX-V CPU only)

There is a supervisory condition on a remote hardwire device connected to the SX-V bus. The unit number "n" designates which device is experiencing problems. This is not an alarm. (Refer to service.)

77 Touchpad Tamper (SX-V CPU only)

The keys on the touchpad at the customer's site have been pressed more than 40 times in a 30 second period without entering a proper access code.

80 Alarm! Fire Panic* (*does not display)

This is a pre-programmed sensor number indicating that the FIRE buttons on the touchpad have been pressed.

- 81 Alarm! Police Panic* (*does not display)**
This is a pre-programmed sensor number indicating that the POLICE buttons on the touchpad have been pressed.
- 82 Alarm! Auxiliary Panic* (*does not display)**
This is a pre-programmed sensor number indicating that the AUXILIARY buttons on the touchpad have been pressed.
- 83 Phone Test**
This is a Phone Test to check the communication of the CPU to the Receiver.
- 84 Opening Report**
The subscriber has entered their Access Code correctly and has disarmed the system.
- 84 Opening Report User n (SX-V only)**
User number "n" (where "n" = a number 0 through 33) at the subscriber's premise has entered their Access Code correctly and has disarmed the system.
- 85 Closing Report**
The subscriber has entered their Access Code correctly and has armed the system.
- 85 Closing Report User n (SX-V only)**
User number "n" (where "n" = a number 0 through 33) at the subscriber's premise has entered their Access Code correctly and has armed the system.
- 86 Alarm! Silent Duress**
The subscriber has entered the Duress (Ambush) Code and is in trouble! This is a silent emergency alarm that cannot be cancelled.
- 87 Auto Force Armed (SX-V only)**
This message indicates that a sensor was in a protest condition (a zone was not closed) so the system armed itself automatically. An SX-V CPU will automatically force arm the system if the protesting sensor has not been closed at the end of the siren timeout period.
- 87 Force Armed**
This indicates that the subscriber has force armed the system by bypassing a sensor that was in an open condition.
- 90 AC Power Failure**
The CPU has lost AC Power for 15 minutes. (Optional--Sensor 90 must be programmed.)
- 91 Low CPU Battery**
The CPU Backup Battery is low and the CPU will shut-down shortly (Refer to service.)
- 92 Alarm! Tamper Loop**
The Hardwire Tamper Loop of the SX-V has been violated.

93 Automatic Phone Test

SXIII, SX-IVA and SX-IVB CPU's: The weekly phone test has just been received. This is a only a test!

SX-V: The automatic phone test has been received (it can be set to call in from 1 to 255 days). This is only a test!

94 Receiver Trouble

SX-III, SX-IVA, and SX-IVB CPU's only. This feature did not work correctly on these earlier models; therefore, when a "94 Receiver Interference" is received, it will automatically be bypassed by the CS-4000.

or

This CPU hasn't heard from any sensor in the previous 2 hour period. This is not an alarm --refer to service.

95 CPU Back in Service

The CPU is now back in service - formerly A/C Power Restored. This message will report when A/C power has been restored. This will follow a "91 CPU Low Battery" report. This may also occur following a PLEVEL change to an SX-IVB CPU.

5.3 CENTRAL STATION MESSAGES DURING THE ZONE COMMAND

The following messages can be received in response to the ZONES or ZONE zz commands.

SAMPLE MESSAGES DURING THE ZONE COMMAND

Zone zz Group gg a

Indicates the data applies to Sensor Number "zz," with Group Number "gg" and Letter Code "a."

Report Alarm!

Indicates that the sensor is currently in alarm condition.

Report Cancelled

Indicates the customer has cancelled the alarm.

Report Supervisory

Indicates this sensor has not successfully transmitted any signals for 24 hours and requires service attention.

Report Low Battery

Indicates the battery in this sensor needs to be replaced.

Bypassed

The sensor has been bypassed either by the customer or by the Central Station operator.

Disabled by C.S.

The sensor has been disabled by the Central Station but has not been deleted.

Battery Low

The last transmission from the sensor indicated that the battery was low.

Battery OK

The last transmission from the sensor indicated that the battery was good.

Received Today

The sensor has successfully transmitted since the last time the CPU did a supervisory check.

Not Received Today

The Zone has not yet transmitted since the CPU did its last supervisory check. This does not necessarily indicate trouble.

Supervisory Display

The sensor is displayed on the CPU along with the supervisory light. The transmitter is in a supervisory condition. It has not transmitted to the CPU.

Open or Activated

The last transmission from the sensor indicated that it was in its open, or alarm, condition. This does not necessarily mean that an alarm was generated.

Closed or Clear

The last transmission from the sensor indicated that it was in its closed, or normal, condition.

Displayed in Alarm

The Sensor Number is displayed on the CPU along with the Alarm light.

Sensor Test Mode

The customer is performing a sensor test (Level 9).

Delay or Exit Fault

Either the sensor is temporarily disarmed by an entry or exit delay, or, if this report is accompanied by REPORT VIOLATION, then the indicated exit door was not closed when the exit delay time expired.

Example of Zone Reports:

Zone 46 Group 05 - E Battery OK Not Received Today Open or Activated	<-----Zone #, Group #, Letter Code (SX-III/IVA, SX-IVB) <-----Sensor has not transmitted today. <-----Sensor is open or activated.
Zone 45 Group 05 - L Battery OK Closed or Clear	<-----Zone #, Group #, Letter Code (SX-V) <-----Sensor is closed.
Zone 36 Group 04 - L Received Today Closed or Clear	<-----Zone #, Group #, Letter Code(SX-IVB) <-----Sensor has transmitted today. <-----Sensor is closed.
Zone 01 Group 12 - A Report Alarm! Closed or Clear Displayed in Alarm	<-----Zone #, Group #, Letter Code (SX-V) <-----Sensor is in alarm. <-----Sensor is closed. <-----Displayed in Alarm window of CPU.

NOTE: SXIII/IVA and SX-IVB CPU's will Report Received Today/Not Received Today. SX-V CPU's do not report this information.

5.4 CENTRAL STATION "FAULT" AND "STATUS" MESSAGES

The following messages can appear as a response to the STATUS command or the FAULT command. The Central Station alert sound will beep on and off until SILENCE is pushed.

Line n Faulty

Indicates that Phone Line "n" is faulty. This will repeat every thirty minutes.

Line n Good

Indicates that Phone Line "n" is good.

Line n In Use

Indicates that Phone Line "n" is processing information back and forth with a CPU.

Line n On Hold

Indicates that Phone Line "n" is Interactive with a CPU and no interactive commands are being used at this time.

Battery Fuse Blown

Indicates the battery fuse in the Receiver has blown. Replace with a 3AG, 2A fuse.

Battery Fuse Good

Indicates the battery fuse in the Receiver is good.

AC Power Failure

Indicate the AC power for the Receiver has failed.

AC Power Good

Indicates that there is AC power to the Receiver.

Low Backup Battery

Indicates the Receiver Backup Battery is low (below 11 VDC).

Battery OK Last Test

Indicates the Receiver Backup Battery is good. The Receiver automatically tests the battery everyday at noon.

Fault (Auto Test) is OFF

The FAULT for this feature is OFF (includes the Backup Battery, Phone Line, AC Power and Battery Fuse feature).

Fault (Auto Test) is ON

The FAULT for this feature is ON (for the Backup Battery, Phone Line, A/C Power and Battery fuse feature).

Ring (Auto Answer) is OFF

The RING feature for this Phone Line is OFF. It will not answer calls.

Ring (Auto Answer) is ON

The RING feature for this phone line is ON. It will answer calls.

5.5 CENTRAL STATION ERROR MESSAGES

The following messages are error messages indicating that the desired action was not performed.

ERROR MESSAGES

ERROR: Invalid Command

The command you entered is not recognized by the Receiver. The HELP message will be displayed along with the message. (HINT: Check the spelling of the command.)

ERROR: Invalid for this CPU!

The command you have just entered is not used with the CPU with which you are presently Interactive.

ERROR: Master Privilege Command!

The command you have entered requires the Master Privilege Password.

ERROR: HI Privilege Command!

The command you have entered requires the Hi Privilege Level Password.

ERROR: Low Privilege Command!

The command you have entered requires the Low Privilege Level Password.

ERROR: There is no CPU on Line!

There is no CPU on line at this time. You are not Interactive with a CPU.

ERROR: Already on Line!

You do not have to answer this line, you are already on line (Interactive) with a CPU.

ERROR: Invalid CPU Type!

The CPU is not compatible with the CS-4000.

ERROR: Wrong Password!

An incorrect password was entered.

ERROR: Unknown CPU type!

The Receiver did not understand the type of message that it received.

ERROR: ACK Timeout ! Chan n

The Receiver did not get an acknowledgement from the device connected to Channel n. Refer to Section 6.2 or 6.3.

ERROR: DSR Timeout! Chan n

This Receiver has lost the signal voltage from the cable connected to Channel n. Check the cable. Refer to Section 6.2 or 6.3.

5.6 COMMUNICATION MESSAGES

The following messages indicate unusual conditions in communicating with a CPU.

COMMUNICATION MESSAGES

Garbled Data

The Central Station had difficulty hearing the CPU. Some data was missed.

No Response from CPU Line n

The Receiver answered Line n and there was no response from a CPU. This is the message that would printout if someone dialed the C.S. phone number by accident.

CPU had Receiver Error

The CPU received a garbled message in last transmission.

CPU told to Call Again

The Receiver tried three attempts to communicate with CPU and failed.

CPU told to stay On Line

The Receiver has told the CPU to go on HOLD.

CPU told to Repeat Report

The Receiver did not understand part of the last report and wants the CPU to repeat the report.

CPU told to Hang Up

The Receiver told the CPU to hang up and terminate the call.

Report Too Long! Data Lost!

The message the CPU sent contained too many characters and data was lost.

Special SX-III/SX-IV Zones Scrub

The Receiver has performed a special operation as part of the ZONES command for the SX-III and SX-IVA CPU's.

WARNING! Incomplete Report!

The message received was only partly understood by the Receiver. The CPU will call back until the message is received completely.

MISCELLANEOUS MESSAGES

Fullrestart

Indicates a FULLRESTART has taken place. You must re-initialize all Receiver Options. Refer to Section 2 or those listed in your STATUS printout.

Restart

Indicates a RESTART has taken place. To verify that all Receiver Options match the STATUS printout:

Type: STATUS <enter>

If you have any questions, refer to Section 2.

5.7 CENTRAL STATION MESSAGES DURING INTERACTIVE PROGRAMMING

The following messages may be received at the Central Station while programming a CPU.

Line n Trapped

This indicates that a trap was successfully entered into the Receiver, the CPU did call in, and the call has been trapped.

Line n Interactive

This is the reply received when a CPU has been trapped successfully and has become Interactive with the Receiver. It is the indication you may begin programming.

Phone Test in Progress

The Receiver has told the CPU to sound the interior auxiliary, police and fire sirens for two seconds each, and the exterior police and fire sirens for two seconds each at the subscriber's CPU.

Phone Test Complete

The Receiver has told the CPU to perform the above test and that test is now complete.

Unprogrammed CPU

The CPU with which you are Interactive is unprogrammed and needs the account and phone numbers programmed into the CPU's memory.

CPU is an SX-III or an SX-IVA

The CPU you are Interactive with is an SX-III or SX-IVA.

CPU is an SX-IVB

The CPU you are Interactive with is an SX-IVB.

CPU is an SX-V

The CPU you are Interactive with is an SX-V.

CPU Clock Set by Receiver

The CPU's Clock has been set by the Receiver to CSDATE and CETIME. (SX-V CPU only).

Error: Idle Hold Timeout!

Error: Line Auto Released

This indicates that a call has been trapped but no interactive programming has been performed in the last 15 minutes so the Receiver has automatically released the line. It may also indicate that the call has been interrupted.

Line n Released

The Receiver has told the CPU to release the line and the CPU has done so, OR the CPU released the line due to something other than Receiver action.

Ready

This indicates the command entered is complete.

Wait Until--Ready

The Receiver is communicating with a CPU at this time and will display Ready when completed.

This is a Very Slow Command!

This is a warning telling you that the command you have entered will take some time to complete. However, an incoming call on another line will interrupt this command to answer the call. Push <ESC> key to end command.

Command Interrupted!

The EVENT or IDBUFFER command has been interrupted by the operator pressing the <ESC> key. The command is terminated at this point.

Command Suspended

The Receiver has suspended the EVENT or IDBUFFER command to answer an incoming call. The CPU that was Interactive has been put on HOLD until the other call has been completed. The Receiver will resume the command after the other call has been completed.

SECTION 6

INTERFACING PERIPHERAL DEVICES TO THE CS-4000

6.1 OVERVIEW

The following sections explain procedures on how to connect and configure the CS-4000 Receiver so it will interface with other devices.

The Receiver has three RS-232 I/O ports that can be used to output data to computers, printers and terminals. There are also pre-programmed formats available for each of those devices. If you are using a format that is similar to one of those formats, but not identical, you may be able to change one or more of the parameters (characteristics) listed in this section to conform to your format.

The following commands will be used to interface with any peripheral devices.

THE CHANNEL COMMAND FORMAT

The three RS-232 I/O ports operate independently of each other. The CHANNEL command is used to set up a particular port to meet your requirements.

The general form of a the command is as follows:

Type: *CHANNEL n option setting* <enter>
where "n" = the channel number,
"option" = feature you want to set,
"setting" = value of the feature.

To reset Channel "n" to its power up default setting:

Type: *CHANNEL n DEFAULT*<enter>

To stop sending any data out on Channel "n" (the channel will still receive data coming in on this channel, if any):

Type: *CHANNEL n OFF* <enter>

To set all of the channel settings to default settings for a specified format (all channels have preset default values for each defined format).

Type: *CHANNEL n FORMAT setting* <enter>

NOTE: The CHANNEL command will automatically cause a complete CHANNEL STATUS listing to be printed out after an option has been changed. To suppress this automatic status listing, and save printer paper, for such commands type a space and the plus sign (+) after the command before pressing the enter key. This will cause only the change you have made to be displayed and printed.

Example: *CHANNEL 1 DSRREQ OFF +*<enter>
CHANNEL 2 BAUD 1200 OFF +<enter>

COMPUTER INTERFACE FORMATS

The computer interface formats available are ITI Generic, Ademco/Caps and Radionics.

- Type: *CHANNEL n FORMAT GENERIC* <enter> for the ITI Generic format
- Type: *CHANNEL n FORMAT ADEMCO* <enter> for the Ademco/Caps format.
- Type: *CHANNEL n FORMAT RADIONICS* <enter> for the Radionics format.
- Type: *CHANNEL n FORMAT ITICOMP* <enter> for the free-form ITI format.

PRINTER FORMATS

There are four different formats for configuring a port (channel) to different printers. The four formats include:

- | | |
|---------|--|
| ITIPRT | - ITI printer format |
| PRINTER | - Flat text, universal printer output format |
| PCPRT | - Personal computer compatible printer format |
| SUPLOW | - Special printer format which outputs in flat text a one line summary for each "supervisory" and "low battery" report line. |

- Type: *CHANNEL n FORMAT ITIPRT* <enter> for the ITI printer format.
- Type: *CHANNEL n FORMAT PRINTER* <enter> for the flat text format.
- Type: *CHANNEL n FORMAT PCPRT* <enter> for the PC compatible printer format.
- Type: *CHANNEL n FORMAT SUPLOW* <enter> for the Supervisory Low Battery flat text format.
- Type: *CHANNEL n LINEFEED ON/OFF* for use with printer formats to specify whether an ACSII Linefeed character is to be appended to each line after each carriage return.

TERMINAL FORMATS

There are three terminal formats available. A terminal connected to the Central Station parallels the built in CRT and keyboard for entering commands and displaying the events on the screen.

- Type: *CHANNEL n FORMAT ANSITERM* <enter> for the ANSI Terminal Output FORMAT.
- Type: *CHANNEL n FORMAT TERMINAL* <enter> for flat text (Universal Terminal) format.
- Type: *CHANNEL n FORMAT TELEVID* <enter> for TELEVIDEO 910 Terminal Output format.

6.2 COMPUTER INTERFACING

NOTE: This section only applies to ITI Generic, ITICOMP, Radionics, or Ademco/Caps computer software packages.

CONFIGURATION OF A PORT

The computer interface formats available are Ademco/Caps, Radionics, and ITI Generic. By using the CHANNEL command a port can be configured to output data to a computer in one of these three formats.

PROCEDURE

1. CONNECT THE CABLE

Connect the cable to Port 1, 2 or 3 (referred to as RS-232 Interface Jacks in the Introduction to this manual.) If you are making your own cable or verifying that the connection has been made correctly, we have supplied cable pinout charts for the Ademco, Radionic, and ITI Generic Formats.

2. CONFIGURE THE PORT USING THE CHANNEL COMMAND

The CHANNEL command will configure a port to predetermined specifications. Each of the three formats preset output specifications so you need only configure the port for one of the three formats. The CHANNEL command is a Low Level command so you will need to enter your Password. Find your format and use the appropriate command below:

Type: *CHANNEL n FORMAT GENERIC* <enter> for ITI Generic format

Type: *CHANNEL n FORMAT ADEMCO* <enter> for Ademco/Caps format

Type: *CHANNEL n FORMAT RADIONICS* <enter> for Radionics format

Type: *CHANNEL n FORMAT ITICOMP* <enter> for the free form ITI format

By entering this command you have set up the Receiver to output its data in the format you have selected.

NOTE: When you configure a port with a CHANNEL FORMAT command, the port is turned OFF. It must be turned ON to begin sending data to the computer. This is done so you will have the opportunity to change other output parameters in case you have a variation of one of the three formats. (For a list of these changes refer to the CUSTOM COMPUTER INTERFACE FORMATTING section.)

3. TURN THE CHANNEL ON

To enable the Receiver to start sending data to your computer you must turn the CHANNEL ON by:

Type: *CHANNEL n ON* <enter> (with n = port number 1, 2, or 3).

ITI GENERIC, RADIONICS, AND ADEMCO FORMATS

1. Prepare your computer system to handle an additional receiver.
2. Go through the initial power up checklist for the Receiver as usual .
3. Make up an RS-232 cable as needed for your computer and use it to connect your computer to one of the three RS-232 Channel connectors on the back of the Receiver.
4. Select the type of computer output you want to use on the RS-232 Channel through the CHANNEL command. This is done by entering "CHANNEL n FORMAT format-type", where "n" is the Channel Number and "format-type" is the type of Computer output you want to use. (See note 1 below.)

Here are some examples:

CHANNEL 1 FORMAT GENERIC	for ITI Generic Output on Channel 1
CHANNEL 2 FORMAT ADEMCO	for Ademco Caps Output on Channel 2
CHANNEL 3 FORMAT RADIONICS	for Radionics Output on Channel 3

5. Verify the Format setting by entering "CHANNEL n STATUS", where "n" is the RS-232 Channel you will be using, and see that the format is correct.
6. Set the Receiver ID number by entering "RID n" and pressing <enter>, where "n" is the single digit number from 0 to 9 that you want to use. If you don't set this number it will default to "0".(Set the UNIT ID letter if needed).
7. Verify the Receiver ID number you just entered by entering "RID STATUS" <enter> and checking that it is the correct number.
8. Turn the Channel ON by entering "CHANNEL n ON" and pressing the <enter>, where "n" is the RS-232 Channel number you will be using.

WARNING: Anytime you set the Format Type for a channel, it will automatically turn the Channel OFF!!!

9. Communication with the computer is now active.

Verify the connection by pressing the PRINT key, this will send an appropriate test record to the computer system.

NOTE: This PRINT key test can be performed any time to verify that the communications are okay.

If any record isn't acknowledged by the computer within 15 seconds (by an ASCII ACK control character) then the message: "ERROR" ACK Timeout! Chan =n" (where "n" is the RS-232 Channel) will alert the Operator, and the Receiver will turn on the continuous Fault tone (pressing the SILENCE key will stop the tone). Obviously, this means the connection has not been established, go back and reread the instructions verifying each step and repeat the test.

NOTES ON COMPUTER INTERFACING

1. When you set the Format Type using the Channel command, all other parameters are automatically set as needed for that format type (baud, parity, word size, stopbits, etc.). If you need to change any of these, do so after selecting the Format Type, since once the format is selected all parameters are set to their standard values.
2. Only reports send information to the computer (i.e. Alarms, Cancellations, Openings, Closings, Supervisories, Phone Tests). Interactive commands and Central Station commands do not send a message to the computer (i.e. ZONES STATUS, TRAP ALL).
3. Since some information is condensed for some of the computer formats, we strongly recommend keeping a logging printer connected to the receiver in order to be sure all the relevant data is captured.
4. After sending information to the computer, the ITI receiver expects an ASCII ACK acknowledgement control character back. If no ACK character is received within 15 seconds the receiver will turn on its steady Fault tone, and display the message. "ERROR: ACK Timeout! Chan = n" (where "n" is the RS-232 Channel). It then skips the unacknowledged information record, and continues with the next information record. The receiver will continue to sound the Fault tone until an operator presses the SILENCE key. (No other reset is necessary). This Fault Tone will always sound at the Receiver even if the SILENT option is on.

It is important to determine immediately the reason there was no acknowledgement (i.e. possibly a break in the connection or illegal values).

The printer runs independently of the RS-232 output so the operator may have to look forward or backward several lines to find the rejected information.

5. The Receiver constantly watches to see that Pin 6 "Data Set Ready" (DSR) is held on by the computer. If Pin 6 ever goes off for more than thirty seconds, the Receiver will turn on the steady Fault tone and display the message "ERROR: DSR Timeout! Chan = n," where "n" is the RS-232 Channel. This is provided to monitor the physical connection between the Receiver and the Computer. This test can be overridden through the Channel command by entering "CHANNEL n DSRREQ OFF," where "n" is the RS-232 Channel, but this is not recommended. The receiver will continue to sound the Fault tone until an operator presses the SILENCE key. (No other reset is necessary). This Fault tone will always sound at the Receiver even if the SILENCE option is on.
6. If any installation problems persist, we request that you verify that the computer port you are using is properly configured by connecting one of your other receivers to it and seeing that it works properly before contacting ITI for further assistance. Our interface is designed to appear to the computer exactly like an Ademco receiver when in Ademco format or like a Radionics receiver when in Radionics format.

GENERAL FORMAT FOR COMPUTER CABLES

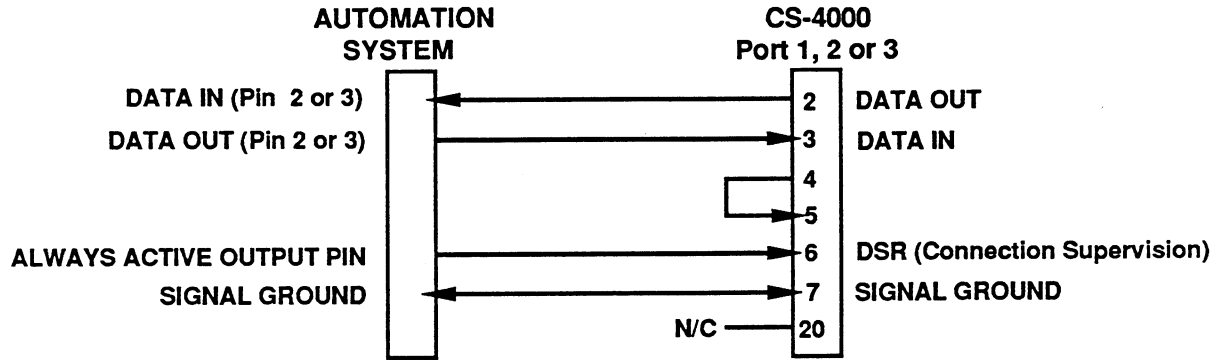

This is a general format of a typical cable configuration between a computer and the CS-4000. Depending on what computer system you are using, you may have to vary the configuration. Pin Numbers for the computer are not listed as they may be different than a standard RS-232 interface setup.

CABLE PINOUTS FOR THE ABM SOFTWARE PACKAGE

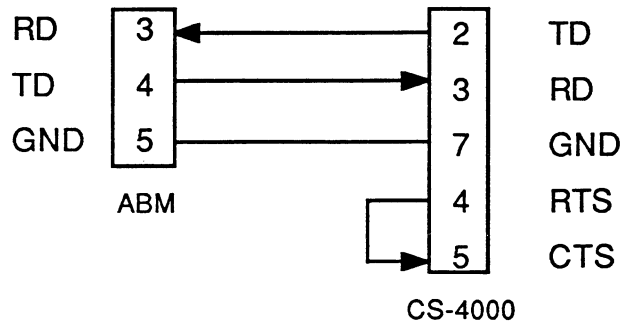

- 1) The ABM software package uses the ITI Generic computer format
- 2) Construct the cable as shown (for use with the 9 pin male connector on the computer side of the cable)
- 3) Configure a Channel on the Receiver for the Generic format.
- 4) Type: *Channel n FORMAT GENERIC* <enter>
- 5) Type: *Channel n DSRREQ OFF* <enter>
- 6) Type: *Channel n ON* <enter>

CABLE PINOUTS FOR THE M.A.S. SOFTWARE PACKAGE

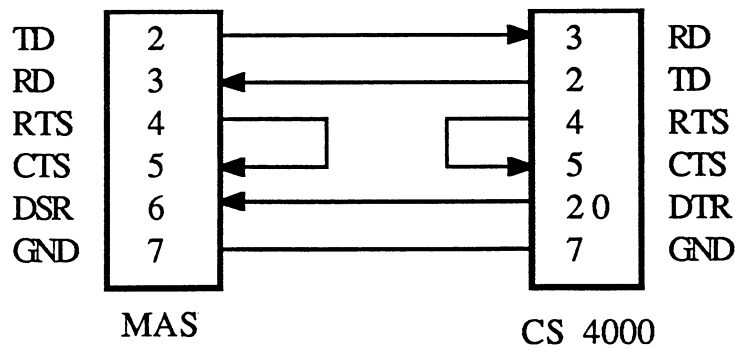
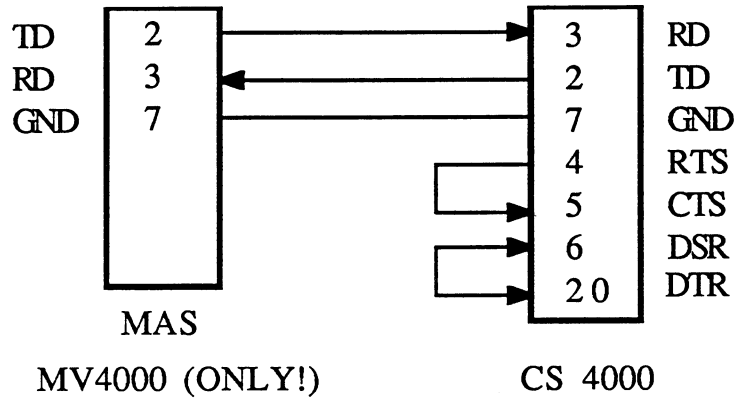

- 1) The MAS computer software package uses the ITI Generic computer format.
- 2) Construct the cable according to the computer you are using.
- 3) Configure a channel for the ITI Generic format.
- 4) Type: *Channel n FORMAT GENERIC*<enter>
- 5) Type: *Channel n ON*<enter>

CABLE PINOUTS FOR THE RADIONICS SOFTWARE PACKAGE

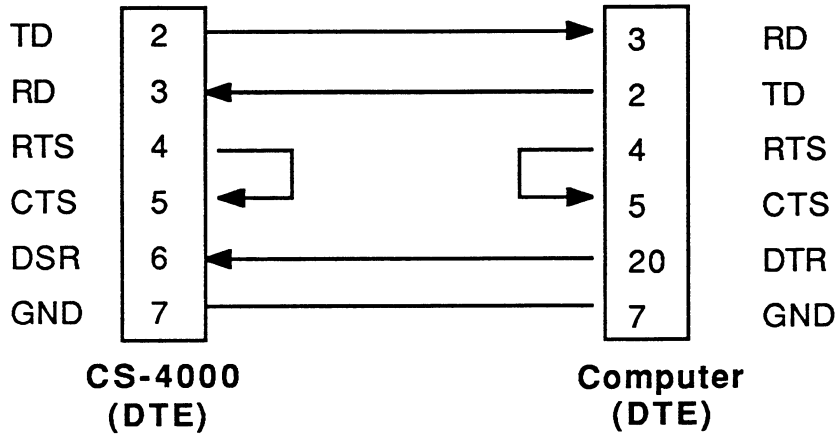

- 1) The Radionics software package uses the Radionics computer format. (This output is identical to the Radionics 6000.)
- 2) Construct the cable as shown.
- 3) Configure a channel for the Radionics format
- 4) Type: *CHANNEL n FORMAT RADIONICS*<enter>
- 5) Type: *CHANNEL n ON*<enter>
- 6) If you get DSR Timeouts (some Radionics packages do not have a busy pin 20): Type: *CHANNEL n DSRREQ OFF* <enter>
- 7) If you get ACK Timeouts, cross 2 & 3, i.e. 2 to 2, and 3 to 3.

6.3 INTERFACING A PRINTER TO THE CS-4000



The Receiver has the ability to output data to a printer through any of the three ports. Operation of each port is controlled by the CHANNEL command. The CHANNEL command can turn a port ON or OFF. The CHANNEL command can configure (set up) a port to output data in a specified format. Since each port operates independently of the other, you can interface up to three different components to the CS-4000.

Only a SERIAL printer may be used, *not* a PARALLEL printer.

NOTE: U.L. Central stations must use a surge suppressor from Inmac Products (1-800-547-5444) part #8214. This suppressor is a 2 outlet, 10 Amp, 3 way protection, U.L. listed device. The CS-4000 and its printer must be connected to this surge suppressor at all times to meet U.L. requirements.

There are five printer formats:

EPSON	- Printer format for an EPSON LX-810
ITIPRT	- ITI printer format
PRINTER	- Flat text, universal printer output format (no special control codes)
PCPRINTER	- Personal computer compatible printer format
SUPLOW	- Special printer format which outputs in flat text a one line summary each "supervisory" and "low battery" report line.

CONFIGURATION OF A PORT

A port must be configured (set up) to output a specific format of data to a printer. This is done by using the CHANNEL n FORMAT setting command. Once a port has been configured, you must then turn it on i.e. CHANNEL n ON

NOTE: On power up CHANNEL 1 is configured for the EPSON format *and* turned ON. The Receiver expects an EPSON LX-810 printer to be connected on power up.

PROCEDURE

1. CONNECT THE CABLE

Connect the cable to the port 1, 2 or 3 (refer to Page 5). If you are making your own cable or verifying that the cable has been made correctly, refer to the CABLE PINOUTS section. We have supplied cable pinout charts for a printer cable titled PRINTER CABLE PINOUTS.

2. CONFIGURE THE PORT USING THE CHANNEL COMMAND

The CHANNEL command will configure a port to certain predetermined specifications. Each of the four formats have preset output specifications so you need only configure the port for one of the four formats. The CHANNEL command is a Low Level command so you will need to enter your Password. Find your format and use the appropriate command below:

- Type: *CHANNEL n FORMAT EPSON* <enter> for EPSON LX-810.
- Type: *CHANNEL n FORMAT ITIPRT* <enter> for ITI Printer format.
- Type: *CHANNEL n FORMAT PRINTER* <enter> Flat text, universal printer output format (no special control codes).
- Type: *CHANNEL n FORMAT PCPRINTER* <enter> Personal computer compatible printer format.
- Type: *CHANNEL n FORMAT SUPLOW* <enter> for flat text supervisory/low battery report line.

By entering this command you have set up the Receiver to output data in the selected format.

NOTE: When you configure a port with a CHANNEL FORMAT command, the port is turned OFF. It must be turned ON to begin sending data to the printer. This enables you to change other output parameters before data starts going out the port. (For a list of these changes refer to the CUSTOM INTERFACE FORMATTING section.)

3. TURN THE CHANNEL ON

To enable the Receiver to start sending data to your printer you must turn the CHANNEL ON. This is done by:

Type: *CHANNEL n ON* <enter> with "n" = port number 1, 2, or 3.

The Receiver is now ready to output data to your printer.

If you have a busy central station you may want to eliminate the blank lines between messages. To do this turn ON the COMPRESS Feature:

Type: *CHANNEL n COMPRESS ON* <return>

TROUBLE SHOOTING HINT #1: (To be used when constructing your own cable.)

If the cable from the CS-4000 to the printer does not have the correct pinout connections, the Receiver will respond with *ERROR ACK Timeout Chan = n* and/or *ERROR DSR Timeout. Chan = n*

The cable pinouts should be inspected for the correct connections.

TROUBLE SHOOTING HINT #2: (To be used when printer is already on line, using DSR feature on cable.)

If the cable from the printer to the CS-4000 is disconnected, the Receiver may respond with a DSR Timeout Error message. The Receiver may also respond with the DSR Timeout Error message if the printer runs out of paper.

CONFIGURATION SPECIFICATIONS FOR THE EPSON LX-810 SERIAL PRINTER

The Epson LX-810 is an inexpensive and easy to use personal printer. The Epson comes configured for use as either a parallel or serial printer. The three CS-4000 channels are all RS-232 serial channels. Three points must be considered when configuring the printer and CS-4000; Serial Cable Connections, Epson LX-810 Serial Interface Switches and CS-4000 Channel Configurations.

Serial Cable Connections

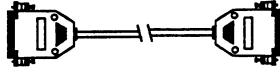

At the present time, the CS-4000 installation kit contains two different serial cable configurations. One cable is for use with the Tandy DMP-106 printer (no longer used in a U.L. listed central station) and has a 25 pin female connector and a 4 pin DIN-type connector. The other cable is fitted with a single 25-pin female connector. It is this second cable configuration that is important and should be used.

The RS232 cable is a 5 conductor cable. The CS-4000 end connector (female) comes pre-wired. No modifications need to be performed on this end. The Epson LX-810 can be configured for hardware or software control. For software control, 4 of the 5 wires will be used. For hardware control, 3 of the 5 wires will be used. Below is a graphic of the proper wiring for each case.

Software Control (XON/XOFF)

NOTE: The Pin 6 - Pin 20 connection when used in conjunction with software control, is useful for detecting cable failures via a DSR time-out. It is not necessary for data communications. It may, however, be required by U.L..

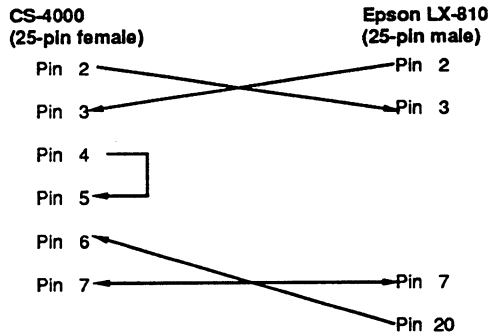

Hardwire Control (DSR/DTR)

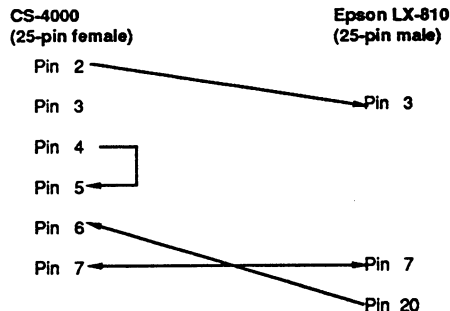

Epson LX-810 Serial Interface Switches

The Epson LX-810 contains 3 banks of DIP switches. Two of the banks are externally accessible. The third is internal and is located on the serial interface #8143 card. It is this internal DIP switch that we are concerned with. Typically, the only feature one might want to modify via this DIP switch is the baud rate.

The baud rate comes factory configured at 300 baud. The CS-4000 channel baud rate is factory configured for 1200 baud. You will have to make the following adjustment. Switches 1, 3, 4 and 7 should be set as follows; **1 - off, 3 - off, 4 - off, 7 - on.** This sets the LX-810 printer for 1200 baud operation. Please refer to the Epson serial Interface #8143 handbook for the various switch settings.

IMPORTANT: Switch 8 **MUST** be set to the ON position. Positioning the switch in the ON position tells the printer to behave as a serial printer. Please check to ensure that this switch is correct.

CS-4000 Channel Configuration

Connect the male end of the 25 pin serial cable described above to one of the three channels on the CS-4000. In the past, the CS-4000 came configured with channel 1 as ITIPRT (set for the DMP-106 printer). Now, the CS-4000 has channel 1 configured as EPSON. Most people use channel 1 for their printers.

We will for our example.

Channel 1 Configuration

Channel 1 is ON
 Format = EPSON
 Lines = 0
 Linefeed = ON
 Baud = 1200
 Wordsize = 7
 Parity = EVEN
 Stopbits = 2
 Control = SOFTWARE
 Protocol = OFF
 InProto = OFF
 DSRreq = ON
 CtrlKeys = OFF
 SupChar = OFF
 UnitId = OFF
 AllUnits = ON
 Compress = OFF
 ApndChar = OFF

If you selected *software* control, enter
CHANNEL 1 CONTROL SOFTWARE

If you selected *hardware* control, enter
CHANNEL 1 CONTROL HARDWARE

Next, enter
 CHANNEL 1 CLEAR
 CHANNEL 1 ON

Upon completion of the CHANNEL 1 ON command, a copy of the channel configuration will be sent to the CS-4000 display as well as the printer.

Please note: If your printer is a Radio Shack DMP-106, you will need to configure the channel as before by typing:

CHANNEL 1 FORMAT ITIPRT
 CHANNEL 1 CLEAR
 CHANNEL 1 ON

6.4 INTERFACING A TERMINAL TO THE CS-4000

The Receiver has the ability to output data to a terminal through any one of the three ports. Operation of each port is controlled by the CHANNEL command. The CHANNEL command can turn a port ON or OFF. The CHANNEL command can configure (set up) a port to output data in a specified format. Since each port operates independently of the other, you can interface up to three different components to the CS-4000.

NOTE: The terminal CRT and keyboard can be used in place of the Receiver CRT and Keyboard.

There are three terminal formats

ANSITERM	-ANSI Terminal Output.
TERMINAL	-Flat text, universal terminal format (no special control codes).
TELEVID	-TELEVIDEO 910 Terminal Output format.

CONFIGURATION OF A PORT

A port must be configured (set up) to output a specific format of data to a terminal. This is done by using the CHANNEL *n* FORMAT setting command. Once a port has been configured, you must then turn it on by the command CHANNEL *n* ON.

PROCEDURE

1. CONNECT THE CABLE

Connect the cable to the port 1, 2 or 3 (refer to Page 5). If you are making your own cable or verifying that the cable has been made correctly, refer to the CABLE PINOUTS section. We have supplied cable pinout charts for a terminal cable titled TERMINAL CABLE PINOUTS.

2. CONFIGURE THE PORT USING THE CHANNEL COMMAND

The CHANNEL command will configure a port to certain predetermined specifications. Each of the four formats have preset output specifications so you need only configure the port for one of the four formats. The CHANNEL command is a Low Level command so you will need to enter your Password. Find your format and use the appropriate command below:

Type: *CHANNEL n FORMAT ANISITERM* <enter> for the ANSI Terminal Output
 Type: *CHANNEL n FORMAT TERMINAL* <enter> for flat text format
 Type: *CHANNEL n FORMAT TELEVID* <enter> for TELEVIDEO 910 Terminal Output format.

By entering this command you have set up the Receiver to output data in the format you have selected.

NOTE: When you configure a port with a CHANNEL FORMAT command, the port is turned OFF. It must be turned ON to begin sending data to the printer. This enables you to change other output parameters before data begins going out the port. (For a list of these changes refer to the CUSTOM INTERFACE FORMATTING section.)

3. TURN THE CHANNEL ON

To enable the Receiver to start sending data to your terminal you must turn the CHANNEL ON. This is done by:

Type: *CHANNEL n ON* <enter> (with "n" being the port number 1,2, or 3)

The Receiver is now ready to output data to your terminal.

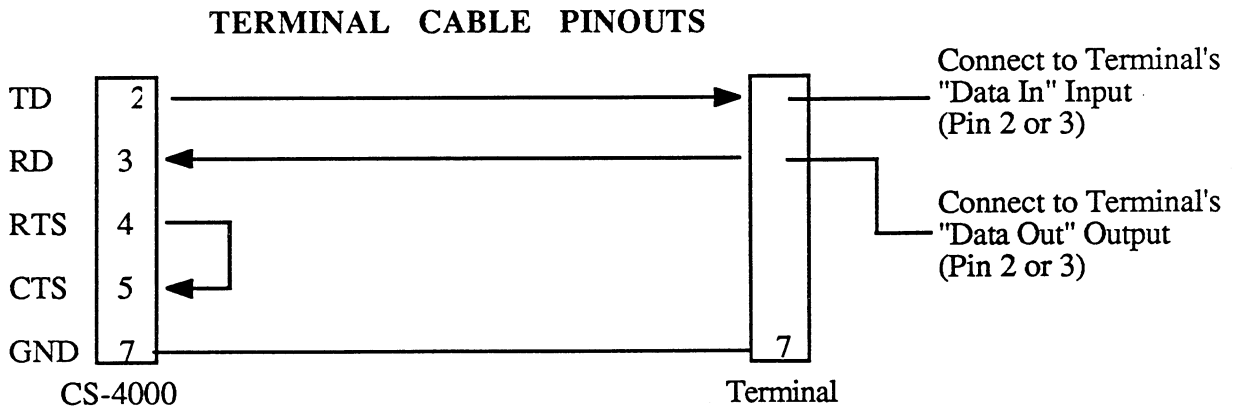

6.5 CUSTOM INTERFACE FORMATTING

The Receiver has three RS-232 I/O ports that can be used to output data to computers, printers and terminals. There are also pre-programmed formats available for each of those devices. If you are using a format that is similar to one of those formats, but not identical, you may be able to change one or more of the parameters (characteristics) listed in this section to conform to your format.

WARNING: It is important that you are familiar with computer systems before attempting to change any of the custom commands listed in this section. Document any changes you have made to any of these commands and keep a copy with your Receiver Options list.

THE CHANNEL COMMAND FORMAT

There are three RS-232 I/O ports which operate independently of each other. The command that is used to configure and turn ON/OFF a port is the CHANNEL command. The CHANNEL command is used to set up a port to meet your requirements.

This is the general form of a command (where "n" is the channel number, "option" is the feature you want to set, and "setting" is what that feature is set to):

Type: *CHANNEL n option setting <enter>*

To reset channel "n" to its power up default setting:

Type: *CHANNEL n DEFAULT <enter>*

To stop sending any data out on channel "n" (the channel will still receive data coming in on this channel, if any):

Type: *CHANNEL n OFF <enter>*

To set all of the channel settings to the default settings for specified format (all channel settings are set to predetermined defaults for each defined format).

Type: *CHANNEL n FORMAT setting <enter>*

For an example of the Channel Options, see Appendix B.

NOTE: The CHANNEL command will automatically cause a complete CHANNEL STATUS listing to be printed out after an option has been changed. To suppress this automatic status listing, and save printer paper, for such commands type a space and the plus sign (+) after the command before pressing the enter key. This will cause only the change you have made to be displayed and printed.

Example: *CHANNEL 1 DSRREQ OFF +<enter>*
CHANNEL 2 BAUD 1200 OFF +<enter>

CUSTOM CHANNEL COMMANDS

NOTE: ITI default RS232 settings are: 1200 Baud 7 bit word, 2 stop bits, mark parity. We recommend that you set your devices to our defaults rather than setting the receiver to your device settings.

To set CHANNEL BAUD rate to "m" (it is not recommended to drive more than one channel at 9600 baud):

Type: *CHANNEL n BAUD m* <enter> (Where m = 110, 300, 600, 1200, 2400, 4800 or 9600)

To set CHANNEL CONTROL where "m" is "OFF" for no control, "SOFT" for Xon/Xoff software control or "HARD" for DSR-DTR hardware control.

Type: *CHANNEL n CONTROL m* <enter>

For use with remote terminals which are unable to generate the ASCII control codes, the option CONTROL KEYS is used at the Central Station:

Type: *CHANNEL n CTRLKEYS on/off* <enter>

<u>OFF</u>	<u>ON</u>	<u>Function</u>
^R	- (minus)	Scroll Back One Screen
^C	= (equal)	Scroll Forward one half Screen
^Z	+ (plus)	Scroll Forward one line
^W] (brace)	"Acknowledge" key
^X	} (bracket)	"Acknowledge All" key
^Y	[(brace)	"Silence" key

Set the CHANNEL DSR REQUIRED option ON or OFF. When ON the Unit will alert the operator if a signal is absent on the RS-232 DSR pin for more than 30 seconds. This is used to assure that the hardware connection to a remote device is okay.

Type: *CHANNEL n DSRREQ on/off* <enter>

The CHANNEL LINES COMMAND specifies the number of lines "m" on one screen when using a remote terminal:

Type: *CHANNEL n LINES m* <enter>

To set the CHANNEL PARITY where "m" = EVEN, ODD, SPACE, MARK, or NONE:

Type: *CHANNEL n PARITY m* <enter>

The CHANNEL PROTOCOL command requires an ASCII 'ACK' character to be returned from the remote device within 15 seconds after a record is sent or else the unit will alert the operator that the channel has "timed out" and is failing. To set the CHANNEL PROTOCOL "ON" or "OFF":

Type: *CHANNEL n PROTOCOL on/off* <enter>

To set the CHANNEL STOPBITS where "m" is 1 or 2:

Type: *CHANNEL n STOPBITS m* <enter>

The SPECIAL CONTROL CHARACTER is used with computer interfaces, where "hh" is the ASCII hex code. If the Central Station sees this character on this channel, it will respond with a special "OKAY" data record. This will allow a computer to monitor the connection to the Central Station during idle periods.

Type: *CHANNEL n SUPCHAR hh* <enter>

The UNITS ID command is for use with printer formats. If set to OFF, the Unit ID letter which normally prints on every line ("A-") is suppressed.

Type: *CHANNEL n UNITID on / off* <enter>

To set the CHANNEL WORDSIZE to m (where "m" = 7 or 8 bits).

Type: *CHANNEL n WORDSIZE m* <enter>

To eliminate writing any blank lines to the printer the CHANNEL COMPRESS feature is turned ON.

Type: *CHANNEL n COMPRESS ON* <enter>

The CHANNEL BACK command will print "x" number of lines back from the Channel's current position:

Type: *CHANNEL n BACK x* <enter>

The CHANNEL CLEAR command will clear the Channel's previous output data:

Type: *CHANNEL n CLEAR* <enter>

The STAMP command will cause receiver time/date to be printed and displayed on the computer every hour on the hour (as does the <F9> Key). To eliminate the STAMP, turn it OFF.

Type: *STAMP ON/OFF* <enter>

WARNING: REMEMBER! Document all of the CHANNEL commands and keep a copy of the changes with your list of Receiver Options.

The APPENDIX CHARACTER command allows the Receiver to send a dummy character to the printer. This command is used for those printers which are not able to receive data and print simultaneously. The hexadecimal character will be ignored by the printer allowing time for the printer to catch up with the data.

Type: *CHANNEL n APPENDCHAR xx* <enter>

SECTION 7

NON-ITI FORMATS

7.1 THE CARETAKER®

The CareTaker® is a combination wireless/hardwire alarm panel that can utilize ON and OFF premise telephones for controlling the alarm system. The CareTaker® has a digitized voice that responds to the commands given by the customer. It also uses the digitized voice in connection with an exterior siren to give a voice message about the type of alarm that has been sounded.

The CareTaker® communicates with the CS-4000 in the "3/1" format. This format is not as fast as the ITI communication format, but the "3/1" format is universally received by all alarm industry central stations.

The CareTaker® sends only basic necessary information to the Central Station. Detailed information regarding alarm status, trouble, etc. can be obtained by service personnel using a touch tone telephone and calling the premises.

The Central Station will display a three-digit Account Number and a single digit Alarm Code. The alarm codes are listed below. Alarm Code 9 is a system restore. This means someone on the premises used the access code to disarm the system during siren alarm time. There are no system restore report provisions for Panic and Duress alarms.

The advantage of the CareTaker® is that the operator has the ability to call the CareTaker® system and get the status of the alarm system, i.e. the exact Zone or Sensor Number with the alarm condition, the Sensor Number with the trouble condition, etc.

The CareTaker® will report 9 different zones to the CS-4000 in two different formats and two different speeds. The alarm codes will report as shown in the chart below.

<u>Zone Number</u>	<u>Description</u>
1	Fire
2	Panic and Duress
3	Intrusion
4	Auxiliary
5	Auxiliary
6	Freeze Detection
7	Supervisory or Trouble
8	Communication Test
9	System Restore

Even though CareTaker® only reports 9 zones, individual point identification of 32 zones is available to the service department when needed.

REPORT FORMAT

CareTaker® reports to the CS-4000 in either 3/1 or 4/1 formats at 10 or 20 baud. "X" or "XX" is inserted automatically as the first digit(s) of the five digit account number when displayed by the CS-4000.

Example: 3/1 format at 10 baud

MON JAN 16,1989 16:13:34 #0263
 Account XX-123 Line 00
 02 Alarm!
 CPU sent 10 Baud 3/1 Format
 Line 01 Released

Example: 4/1 format at 10 baud

MON JAN 16,1989 16:16:29 #0265
 Account XX-234 Line 00
 02 Alarm!
 CPU sent 10 Baud 4/1 Format
 Line 00 Released

Example: 4/1 format at 20 baud

MON JAN 16,1989 16:17:51 #0266
 Account XX-234 Line 00
 02 Alarm!
 CPU sent 20 Baud 4/1 Format
 Line 00 Released

TROUBLESHOOTING NOTE: If the Receiver is set up for the 1400 HZ handshake, the switches on the communicator of the CareTaker® must both be in the DOWN position. If the Receiver is set up for the 2300 HZ handshake the switches on the card must be in the UP position.

7.2 NON ITI FORMATS

The CS-4000 has been designed with the capability to receive calls from Non-ITI format panels.

CS-4000 HANDSHAKE SEQUENCE FOR USE WITH OTHER FORMATS

When the CS-4000 receives a call it first assumes the panel is an ITI-type and produces the ITI handshake. If there is no response, it then produces one other handshake, either a 1400 HZ or a 2300 HZ **not both**, depending upon how it is configured. It cannot be configured to respond with all three handshakes.

To cause the CS-4000 to produce a second handshake, use the OTHER 1 command:*

* This command is a high level command.

Type: *OTHER 1 1400* <enter>, or

OTHER 1 2300 <enter> (This is the default selection upon power up.)

The CS-4000 will confirm your selection.

Panel and receiver communications are described in the CS-4000 Phone Window as follows:

ESUP This is the echo suppressor disable tone.

COMM This means the Receiver is giving the ITI carrier and/or communicating with an ITI panel.

If the panel does not respond to the ITI carrier frequency, the Receiver produces the other handshake frequency which has been configured (1400 or 2300 HZ).

The Phone Window will show:

LISTEN A handshake has been given and the receiver is waiting for a response in a non-ITI format.

2300 The Receiver is giving the 2300 HZ handshake.

-or-

1400 The Receiver is giving the 1400 HZ handshake.

USING THE CS-4000 TO RECEIVE NON-ITI FORMATS

1. The CS-4000 will not answer both handshakes. You must choose either the 1400 HZ or 2300 HZ handshake for *all* non-ITI panels (use OTHER 1 command). This does not include BFSK, which is able to be received regardless of the OTHER 1 command setting.
2. The Receiver will always answer any line with the ITI handshake followed by the OTHER handshake choice.
3. The BFSK format will reply just as it does on the Radionics 6000 Receiver.
4. A non-ITI panel will report an account number of XX-*nnn* or X*n*-*nnn*. The Receiver inserts the letter X for the unused portions of a non-ITI account number.

5. The CS-4000 has one modem to answer all four lines. It will process the calls one by one as they are received. Since the Receiver always gives the ITI handshake first, the approximate time period for the processing of a non-ITI type panel will range from 30 seconds to one minute.
6. No account number may have all digits set to the same number. The following is an example of an invalid account number:

Account # = 444 Wrong!!!!

NOTE: This does not apply to 4/1 or 4/2 formats.

7. Care must be used when mixing 3/1 and 3/1 Extended in the same call when the same number is used for the alarm code and the extended code. If this occurs, a situation could arise in which the CS 4000 would incorrectly combine a 3/1 Round with a 3/1 Extended Round. This situation is illustrated in the following example in which a panel is reporting an alarm on Zone 5 using Alarm Code 5 and a Restoral on Zone 5 using Extended Code 5.

1st round:
 1235 (Account 123 - Alarm Zone 5)
 1235

2nd round:
 5555 (Restoral Zone 5)

The CS4000 will combine both rounds into 3/1 Extended and display:

Account XX- 123
 55 Alarm

Which is incorrect! It should have displayed:

Account XX-123
 05 Alarm (Alarm Zone 5)
 55 Alarm (Restoral Zone 5)

The solution to this problem is to never define extended codes to use the same number as alarm codes when programming panels that can report both 3/1 and 3/1 Extended formats in one call.

8. The account number is displayed only once per report. This is the first account number received. Any subsequent transmissions within the same call that have DIFFERENT account numbers will be displayed under the first account number received, and any other account numbers are ignored.

The following panels have been tested and found to be compatible with the CS-4000 in the formats listed:

<u>PANEL/FORMAT</u>	<u>SPEED</u>	<u>BAUD</u>	<u>HANDSHAKE</u>
<u>FBI XL-1215[†]</u>			
Franklin/DEI/Sescoa/Radionics	3/1	20 Baud	2300 HZ
Radionics/Adcor	3/1	20 Baud	1400 HZ
Ademco	3/1	10 Baud	1400 HZ
Silent Knight	3/1	10 Baud	1400 HZ
<u>NAPCO MA 850, 900, 950</u>			
Ademco/Adcor/Vertex/Silent Knight	3/1, 3/1 EXT & 4/2	10 Baud	1400 HZ
Sescoa/Vertex/DCI/Franklin	3/1, 3/1 EXT & 4/2	20 Baud	2300 HZ
Radionics Super Fast	3/1, 3/1 EXT & 4/2	40 Baud	2300 HZ
Silent Knight Fast 3/1 & 4/2	3/1, 3/1 EXT & 4/2	15 Baud	1400 HZ
Radionics/DCI/Franklin	3/1, 3/1 EXT & 4/2	10 Baud	2300 HZ
<u>NAPCO Magnum Alert 800[†]</u>			
Ademco/Adcor/Vertex/Silent Knight	3/1, 3/1 EXT & 4/2	10 Baud	1400 HZ
Sescoa/Vertex/DCI/Franklin	3/1, 3/1 EXT & 4/2	20 Baud	2300 HZ
Radionics Super Fast	3/1, 3/1 EXT & 4/2	40 Baud	2300 HZ
Silent Knight Fast 3/1 & 4/2	3/1, 3/1 EXT & 4/2	15 Baud	1400 HZ
Radionics/DCI/Franklin	3/1, 3/1 EXT & 4/2	10 Baud	2300 HZ
<u>NAPCO DD-1486</u>			
Ademco/Adcor/Vertex/Silent Knight	3/1, 3/1 EXT & 4/2	10 Baud	1400 HZ
Sescoa/Vertex/DCI/Franklin	3/1, 3/1 EXT & 4/2	20 Baud	2300 HZ
Radionics Super Fast	3/1, 3/1 EXT & 4/2	40 Baud	2300 HZ
Silent Knight Fast 3/1 & 4/2	3/1, 3/1 EXT & 4/2	15 Baud	1400 HZ
Radionics/DCI/Franklin	3/1, 3/1 EXT & 4/2	10 Baud	2300 HZ
<u>Moose Z1100</u>			
Ademco/Adcor/Vertex/Silent Knight	3/1 & 3/1 EXT	10 Baud	1400 HZ
Silent Knight Fast	3/1 & 3/1 EXT	15 Baud	1400 HZ
*Acron/Sescoa/Vertex/DCI/Franklin	3/1 & 3/1 EXT	20 Baud	2300 HZ
*Radionics Super Fast	3/1 & 3/1 EXT	40 Baud	2300 HZ
* Compatible only with Moose software rev. DCS 201A or later.			
<u>Moose System 911[†]</u>			
Ademco/Adcor/Vertex/Silent Knight	3/1 & 3/1 EXT	10 Baud	1400 HZ
Silent Knight Fast	3/1 & 3/1 EXT	15 Baud	1400 HZ
*Acron/Sescoa/Vertex/DCI/Franklin	3/1 & 3/1 EXT	20 Baud	2300 HZ
*Radionics Super Fast	3/1 & 3/1 EXT	40 Baud	2300 HZ
* Compatible only with Moose software rev. DCS 201A or later.			
<u>ITI Caretaker[®]</u>			
Sescoa/Franklin	3/1	10 Baud	2300 HZ
Ademco/Silent Knight	3/1	10 Baud	1400 HZ

<u>Acron DD-3†</u>			
Sescoa/Vertex/Franklin	4/2	20 Baud	2300 HZ
<u>Morse MDC-16D</u>			
Generic	3/1, 3/1 EXT, 4/1 & 4/2	10 Baud	1400/2300 HZ
Generic	3/1, 3/1 EXT, 4/1 & 4/2	20 Baud	1400/2300 HZ
Radionics BFSK	BFSK		2300 HZ
<u>Silent Knight 2720†</u>			
Silent Knight	3/1	10 Baud	1400 HZ
Sescoa	3/1	10 Baud	2300 HZ
Radionics BFSK	BFSK		2300 HZ
<u>Radionics 8112</u>			
Sescoa/Franklin	3/1, 3/1 EXT	40 Baud	1400/2300 HZ
Silent Knight	3/1, 3/1 EXT	20 Baud	1400/2300 HZ
Ademco	3/1, 3/1 EXT	10 Baud	1400/2300 HZ
Ademco	3/1, 3/1 EXT	20 Baud	1400/2300 HZ
Radionics Super Fast	3/1, 3/1 EXT.& 4/1	40 Baud	1400/2300 HZ
Radionics BFSK	BFSK		2300 HZ
<u>Radionics 6112</u>			
Sescoa/Franklin	3/1, 3/1 EXT	40 Baud	1400/2300 HZ
Silent Knight	3/1, 3/1 EXT	20 Baud	1400/2300 HZ
Ademco	3/1, 3/1 EXT	10 Baud	1400/2300 HZ
Ademco	3/1, 3/1 EXT	20 Baud	1400/2300 HZ
Radionics Super Fast	3/1, 3/1 EXT.& 4/1	40 Baud	1400/2300 HZ
Radionics BFSK	BFSK		2300 HZ

† Indicates that the panel is not currently UL listed.

NOTE: The above list assumes your CS-4000 has software version dated 6/02/88 or later. To see what version you have, Type: VERSION <enter>.

PANELS THAT ARE NOT COMPATIBLE WITH THE CS-4000

NAPCO BFSK	Any Touchtone type panel	Any format using a Parity digit
Acron DD1 and DD2	Any SEIA format communicator	Ademco fast

The OTHER1 command controls the handshake frequency for answering a Non-ITI panel.

Type: *OTHER* <enter> for current OTHER status.

Type: *OTHER 1 1400* <enter> for the CS-4000 to give a 1400 HZ handshake.

Type: *OTHER 1 2300* <enter> for the CS-4000 to give a 2300 HZ handshake.

The OTHER 2 command

Type: *OTHER 2 RADIONICS* <enter>

Type: *OTHER 2 OFF*

OTHER 2 RADIONICS

All 3/1 reports are displayed in the Radionics Hex Format. This means that in addition to alarms the following messages will be displayed:

<u>Code</u>	<u>Message</u>
0-9	Zones 0-9 in alarm
B	Opening
C	Closing
D	Cancel
E	Restoral
F	Supervisory

OTHER 2 OFF

Disables the Radionics Hex option so that all 3/1 reports are displayed as "X Alarm!"

Examples of Non-ITI Format Messages:

WED NOV 11, 1987 09:48:15 #0028 Account XX-123 Line 01 0D Alarm! 0C Alarm! CPU sent Slow 3/1 Format Line 01 Released	<-----Date, Time, Report # <-----Account (123), Line Number <-----Alarm Codes <-----Alarm Codes <-----Type of CPU <-----Release Message
WED NOV 11, 1987 10:15:57 #0036 Account X1-234 Line 01 0B Alarm! CPU sent Slow 4/1 Format Line 01 Released	<-----Date, Time, Report # <-----Account (1234), Line Number <-----Alarm Codes <-----Type of CPU <-----Release Message
WED NOV 11, 1987 10:24:57 #0036 Account X1-234 Line 01 1C Alarm! CPU sent Fast 4/2 Format Line 01 Released	<-----Date, Time, Report # <-----Account (1234), Line Number <-----Alarm Codes <-----Type of CPU <-----Release Message

The CS-4000 will display the type and the speed of format sent by the CPU for all calls that are received. Listed below are possible types and speeds:

<u>TYPE</u>	<u>SPEED</u>
3/1	10 Baud
3/1 EXT.	15 Baud
4/1	20 Baud
4/2	30 Baud
Radionics BFSK	40 Baud

The CS-4000 also displays the frequency of the handshake in the Phone Window when a call is being received.

OTHER 2 RADIONICS

All 3/1 reports are displayed in the Radionics Hex Format. This means that in addition to alarms the following messages will be displayed:

<u>Code</u>	<u>Message</u>
0-9	Zones 0-9 in alarm
B	Opening
C	Closing
D	Cancel
E	Restoral
F	Supervisory

OTHER 2 OFF

Disables the Radionics Hex option so that all 3/1 reports are displayed as "X Alarm!"

Examples of Non-ITI Format Messages

WED NOV 11,1987 09:48:15 #0028	Date, Time, Report #
Account XX-123 Line 01	Account (123), Line Number
0D Alarm!	Alarm Codes
0C Alarm	Alarm Codes
CPU sent Slow 3/1 Format	Type of CPU
Line 01 Released	Release Message

WED NOV 11, 1987 10:15:57 #0036	Date, Time, Report #
Account X1-1234 Line 01	Account (1234), Line Number
0B Alarm!	Alarm Codes
CPU Sent Slow 4/1 Format	Type of CPU
Line 01 Released	Release Message

The CS-400 will display the type and the speed of format sent by the CPU for all calls that are received. Listed below are possible types and speeds:

<u>TYPE</u>	<u>SPEED</u>
3/1	10 Baud
3/1 EXT.	15 Baud
4/1	20 Baud
4/2	30 Baud
Radionics BFSK	40 Baud

The CS-4000 also displays the frequency of the handshake in the phone window when a call is being received

CONVERSION OF NON-ITI FORMATS

NOTE: for U.L. installations, Underwriters Laboratories requires that the following conversion options be used. Additionally, if you are exclusively using the CS-4000 display and a printer for monitoring, reconfiguring the display of alarm code reports from non-ITI format alarm panels is recommended by the manufacturer.

If the alarm panel reporting to a CS-4000 is not reporting in the ITI format, then all signals will report as an alarm. For example, if alarm code 03 happened to be a fire alarm, alarm code 07 an opening report and alarm code 09 a restoral report, the CS-4000 would display:

03 Alarm!
07 Alarm!
09 Alarm!

The CS-4000 can reconfigure the display of non-ITI alarm messages. For example, the above reports could be displayed as:

BYPASS
CANCEL
CLOSINGS
LOWBAT(TERY)
OPENINGS
RESTORAL
SUPERVISORY
TAMPER

The following procedures will enable an operator to change the displaying of the report of an alarm code to any of the above options. The list will apply to the following formats: 3/1, 3/1 Extended, 4/1 and 4/2. Each format may have any alarm code converted to one of the eight options. For example:

Before conversion, Alarm Code 07 will be received as an alarm:

WED JAN 25, 1989 11:19:19 #0069
Account XX-211 Line 02
07 Alarm!
CPU sent 10 Baud 3/1 Format
Line 01 Released

After conversion (in this case to Supervisory), Alarm Code 07 is received as follows:

WED JAN 25, 1989 11:19:19 #0069
Account XX-211
07 Supervisory
CPU sent 10 Baud 3/1 Format
Line 01 Released

HOW TO CONVERT AN ALARM CODE

To convert an alarm code in the 3/1 Format:

Type: *E31 n option <enter>*
 Where: E31 =the 3/1 Format
 "n" =the alarm code character (0-9 and B-F)
 "option" =a selection from the option list

For example, if you wanted to make Alarm Code 9 be RESTORAL, then you would

Type: E31 90 RESTORAL <enter>

To convert an alarm code in the 3/1 Extended Format:

Type: *E3Xnn option <enter>*
 Where: E3X =the 3/1 Extended format
 "nn" =the two character alarm code (0-9 and B-F)
 (NOTE: The letter A should not be used for either character.)
 "option" =a selection from the option list

To convert an alarm code in the 4/2 Format:

Type: *E42 nn option <enter>*
 Where: E342 =the 3/1 Extended format
 "nn" =the two character alarm code (0-9 and B-F)
 (NOTE: The letter A should not be used for either character.)
 "option" =a selection from the option list

DISPLAY OF THE CONVERTED ALARM CODES

Since a non-IT format alarm message may be converted to one of the eight options, it will be displayed on the CS-4000 CRT and shown on the printer as the new alarm code configuration.

Example: Using the 3/1 format you have converted the following alarm codes:
 Alarm Code 07 = Supervisory
 Alarm Code 09 = Restoral

An Alarm Code 09 would be displayed- -
 WED JAN 25, 1989 11:19:19 #0069
 Account XX-211 Line 02
 09 Restoral
 CPU Sent 10 Baud 3/1 Format
 Line 01 Released

An Alarm Code 09 would be displayed- -
 WED JAN 25, 1989 12:10:19 #0069
 Account X-211 Line 02
 09 Restoral
 CPU sent 10 Baud 3/1 Format
 Line 01 Released

HOW A CONVERTED ALARM CODE REPORTS TO THE COMPUTER

Once an alarm code has been converted to one of the eight options it will report to the computer the alarm condition letter code corresponding to the conversion.

Example: (Using the Generic Computer output Format)
 Bypass reports in as a B
 Alarm reports in as an A
 Closings report in as a C
 Restorals report in as a W, etc.

For more information refer to Appendix A, THE ITI GENERIC COMPUTER OUTPUT FORMAT. The Radionics and Ademco/Caps computer output formats will also report the converted alarm codes as they normally would according to their programming.

WARNING! ALL alarm codes that are converted will report as the new alarm code. The CS-4000 cannot distinguish a particular panel type, so any and all incoming calls of a format (3/1, 3/1 EXT etc.) will be converted to any changes you have made. This means all panels of the format must use the same alarm code listing. If this is not followed, calls may be received and acted upon incorrectly.



APPENDIX A

ITI GENERIC COMPUTER OUTPUT FORMAT

This output format was designed to pass alarm information out one of the RS-232 Channels in a generalized form for use by software developers for a computer monitoring system. The information below has been updated to include ITI's new SX-V system. If you are not developing custom software for the ITI format you do not need to read Appendix A.

BASIC RECORD LAYOUT

<u>BYTE</u>	<u>DESCRIPTION</u>
0	ASCII Line Feed Character (LF)
1	Receiver ID Digit
2	Phone Line Number Digit
3	Highest character of the ITI Account Number
4	CPU panel type/zone Attribute Code
5-8	Lower 4 characters of the ITI Account Number
9	Group Number
10	User ID for openings and closings
11-12	Zone Number
13	Alarm condition code
14	ASCII Carriage Control Character (CR)

DETAILED DESCRIPTIONS

Byte 0 is ALWAYS an ASCII linefeed character (LF) (0x0a in hexadecimal). This marks the start of the record.

Byte 1 is the Receiver ID digit, is set in the Receiver via the RID command. It may be set to the ASCII characters "0" through "9." The default value of the RID command is 0.

Byte 2 is the phone line number digit, indicates which of the Receiver's phone lines the report came in on. Currently, it may take on the ASCII characters "0" through "4."

Byte 3 is the highest character of the five-character account number, (i.e. the "A" in account number "AB-CDE").

Byte 4 is the CPU panel Type/Zone attribute code. This 8-bit Byte must be split into two parts, the Upper Nybble (first 4 bits) and the Lower Nybble (last 4 bits).

The Upper Nybble holds a code designating the panel type. Only hexadecimal values "2" through "7" are used, so that the entire Byte remains an ASCII printable character.

<u>UPPER NYBBLE</u>	<u>DESCRIPTION</u>
2	Unknown CPU Panel
3	Non-ITI Panel
4	SX-III OR SX-IVA
5	SX-IVB
6	SX-V
7	All future ITI Panels

The Lower Nybble holds a code describing the zone's attributes. This value corresponds to the "letter code" in the Group command, but must be converted using a table to get the right "letter code."

(NOTE: In general, this is probably not very useful, and was included here simply because it was available.)

If the Upper Nybble is a "2" (unknown), the Lower Nybble is currently set to "0;" however, we may need to use other values for future expansion.

If the Upper Nybble is a "3" (non-ITI) the Lower Nybble is used as a subcode to identify what type of non-ITI panel it was.

<u>LOWER NYBBLE</u>	<u>DESCRIPTION</u>
0	Anything not listed below
1	Slow 3/1 Format
2	Fast 3/1 Format
3	Slow 3/1 Extended Format
3	Fast 3/1 Extended Format
5	Slow 4/1 Format
6	Fast 4/1 Format
7	Slow 4/2 Format
8	Fast 4/2 Format
9	Radionics 3/1 Hex
A	Radionics BFSK

NOTE: These are tentative at this time and subject to change.

NOTE: Other non-ITI Panel types may be added in the future!

If the Upper Nybble is a "7" (all future ITI Panels), it is not certain that the Lower Nybble will really be the attribute code (we reserve the right to use it for something else).

Byte 5-8 is the lower four characters of the five character account number (i.e. the "BCDE" in account number "AB-CDE").

Byte 9 is the group number and is set in the Receiver via the GROUP command. It may be set to the ASCII characters "0" through "9" or the ASCII characters "A" through "F." ("A" through "F" correspond to Group Numbers 10 through 15.) NOTE: Not all of the fifteen values are currently used.

Byte 10 is the user number and indicates CPU user ID if reported to the Receiver for openings and closings. (SX-III/SX-IV AND SX-IVB CPU's do not report User ID, default User ID is ASCII "0.")

Byte 11-12 are the zone numbers, indicating the reporting zone number.

Byte 13 is the alarm condition code, indicating the condition of the zone reporting to the Receiver. (Other codes may be added in the future.)

<u>CODE</u>	<u>DESCRIPTION</u>
A	Alarm!
R	Cancel
E	Exit Fault
S	Supervisory
L	Low Battery
B	Bypassed
T	Tamper Alarm
O	Opening Report (non-ITI only!)
C	Closing Report (non-ITI only!)
W	Restoral

Byte 14 is ALWAYS an ASCII carriage control character <CR> (0x0d in hexadecimal). This marks the end of the record.

GENERAL OBSERVATIONS

The format is specifically designed so that every byte in it is some kind of 7 bit ASCII printable character (no control codes) except for Byte 0, the linefeed character signaling the start of the record and Byte 14, and the carriage control character signaling the end of the record.

We recommend that you anticipate future changes and additions, that is, expect that someday, any one of the the fields described above may contain a value other than those defined today. We recommend that you test for the current legal values, and display and notify the operator of any exceptional conditions (i. e. unexpected values). For example, perhaps some day there will be more than four phone lines (0 through 4), requiring us to add letter codes for Line "A" through "Z" and "a" through "z" plus the special characters "!@#\$%^&*()_+ in order to designate them all. Your program should either accept totally generalized data (allowing any value to be in any field) or spit out any exceptions to expected values to the operator (this is a matter of personal programming philosophy). In the latter case, you would probably want to send a NAK back to the Receiver under the assumption that the data had been garbled. This is our recommended approach since the data may have been garbled.

THE SPECIAL PRINT TEST RECORD

This special record is triggered by the Print Test Key or whenever a date/time line is displayed. It is pre-defined to ALWAYS be:

<u>BYTE</u>	<u>DESCRIPTION</u>
0	ASCII linefeed character <LF>
1	"I"
2	"T"
3	ASCII space character
4	"I"
5	"R"
6	"C"
7	"V"
8	ASCII space character
9	"2"
10	"3"
11	"4"
12	"A"
13	ASCII carriage return character <CR>

NOTE: This record is one byte shorter than a normal data record!

THE SPECIAL "OKAY" RECORD

This special record is triggered by sending an "s" (lowercase "S") into the Receiver from the computer. It may be used at any time to determine that the Receiver is on line and active. It is pre-defined and is ALWAYS:

<u>BYTE</u>	<u>DESCRIPTION</u>
0	ASCII linefeed character <LF>
1	"0"
2	"0"
3	ASCII space character
4	"O"
5	"K"
6	"A"
7	"Y"
8	ASCII space character
9	"@"
10	ASCII carriage control character <CR>

PROTOCOL (ACK/NAK)

Once the Receiver has transmitted a record to your computer, it expects to receive either an ASCII ACK acknowledgement character (0x06 hexadecimal) or an ASCII NAK negative acknowledgement character (0x15 hexadecimal) back.

If the Receiver receives an ACK from the computer, it is satisfied that the last record sent was accepted correctly and will continue with the next record as soon as one is ready to send.

If the Receiver receives a NAK from the computer, it will resend the last record over, assuming the record was not received properly by the computer. If too many NAK's are received for the same record, the Receiver goes into a special hardware fail type of alert and then skips the faulty record and continues with the next record as soon as one is ready to send.

If neither an ACK or a NAK is received within 20 seconds, the Receiver goes into a special alert and then skips the unacknowledged record and continues with the next record as soon as one is ready to send.

You should not send an ACK to the Receiver until you are sure the data is good. You will probably want to process the record and store it to disk before acknowledging it with the ACK.

To tighten up even more on data integrity, one could always send a NAK the first time and require two identical rounds of the same record before sending an ACK to acknowledge it.

PACING (START/STOP)

The flow of data records into your computer system can be paced by you as needed. The generic format responds to Xon/Xoff codes sent from your computer to start/stop data from the Receiver.

Xon is the ASCII control character ^Q (0x11 hexadecimal), Xoff is the ASCII control character ^S (0x14 hexadecimal).

Sending an Xoff to the Receiver, the Receiver will stop sending characters to your computer until you send an Xon character telling it to resume sending.

In order to avoid being accidentally Xoffed forever, the Receiver has a maximum Xoff time limit of two minutes. If the time limit expires the Receiver goes into a special alert state and resumes sending as if an Xon had been received.

APPENDIX B

THE RS-232 PORT FORMAT AND SIGNAL EXPLANATION

This section covers an in-depth look at the different methods of RS-232 communication used by the CS-4000. Parameters covered include ACK/NAK, XON/XOFF, software/hardware control methods, the PINS command and DSR requirements. This information may be useful in the configuration of a cable to a device that has a pinout configuration different than those listed in the manual.

THREE RS-232 COMMUNICATION CHANNELS

- (1) All channels support full duplex, continuous communications at speeds up to 9600 Baud.
- (2) All channels receive data on Pin 3, send data out on Pin 2, receive a control input (stop/start) on Pin 6, send a control output (stop/start) on Pin 20, and use Pin 7 as signal ground.
- (3) In addition, Channel 1 uses two additional inputs and one additional output. Pins 5 and 8 are unused inputs at this time, and Pin 4 is an output that is held active whenever the channel is turned on.

NOTE: Pins 4 and 5 of Channel 1 should be jumpered together.

- (4) Three stop/start methods are provided to control data flow between CS-4000 and external devices.

HARDWARE

This method is commonly used with printers which use a "busy" output line. Pin 6 of the CS-4000 channel connector is an input which controls whether the CS-4000 will send data or not. Pin 6 should be connected to an output on the external device which indicates when it is ready to accept data. If Pin 6 is held active (positive voltage with respect to Pin 7), then the CS-4000 will send data. If Pin 6 is held inactive (negative with respect to Pin 7), then the CS-4000 will stop sending data within two characters. Pin 20 is used in the hardware control mode as a "ready to receive" output from the CS-4000. The CS-4000 will hold Pin 20 active (positive) when it is ready to receive data, and inactive (negative) when it is unable to receive data.

NOTE: After Pin 20 is set inactive, the CS-4000 can still receive up to 32 characters.

SOFTWARE

This method is commonly used with computers and occasionally with printers. It uses the control character XON (11₁₆) and XOFF (13₁₆) to control data transfer between the CS-4000 and an external device. When the CS-4000 receives an XOFF character from the external device, it will stop sending data within two characters. It will not send data again until XON character is received, the channel is forced to restart by the operator, or it has been in the XOFF state for 2 minutes, after which the Receiver will automatically return to the XON state.

Likewise, when the CS-4000 is receiving data, it will send an XOFF character when it can no longer receive data, and it will send an XON character when it is ready to receive data again.

NOTE: After XOFF is sent, the CS-4000 can still receive up to 32 characters.

OFF

This method is often used with a remote terminal. It allows both devices to send and receive data unrestricted. Data out from the CS-4000 cannot be stopped by the external device and the CS-4000 will not warn the external device when it can no longer receive data.

WARNING: USE OF THIS CONTROL METHOD MAY RESULT IN LOSS OF DATA IF USED INCORRECTLY.

DSRREQ

This option is used to assure the CS-4000 that the cable connection to the remote device is intact. To use this option, Pin 6 of the Channel connector must be connected to an output from the external device which is always held active (positive voltage with respect to Pin 7). As long as the cable connection is intact, the CS-4000 will see its Pin 6 input is in the active state and will send and receive data normally. If the cable connection is broken, however, the CS-4000 will see that Pin 6 is inactive and will immediately stop sending data until Pin 6 is again in the active state. The operator will be alerted if the input on Pin 6 is inactive for more than 15 seconds.

PROTOCOL

Channel protocol is a control sequence which is often used with remote computer interfaces. It uses the control characters ADK(06) and NAK (15₁₆) to inform the sending device that data was or was not received properly. After the CS-4000 sends a "pack" of information to an external device, it will wait for a response from that device in the form of an ACK or a NAK. If an ACK is received, the CS-4000 will go on to the next packet of information (if any). If a NAK is received, the CS-4000 will re-send the last packet and again wait for an ACK/NAK response.

PINS

Pins is a diagnostic command used as an aid in troubleshooting a defective channel. By typing "PINS X", where X is the channel number (1, 2, or 3) the CS-4000 will display current status on the specified channel of the Input Pins 5 (CTS) & 6 (DSR), Output Pins 4 (RTS) & 20 (DTR), the current control method which is active (hardware, software or none), whether the transmitter or receiver has been disabled by the control method, and counters for channel error conditions including breaks, parity, framing and overrun errors. These error counters are reset to 0 each time the channel is turned on.

Example:

```
Channel =
Interrupt Enable =
 4 RTS+ =
 5 CTS =
 6 DSR =
20 DTR+ =
Control Method =
Transmit Enabled =
Receiver Enabled =
Breaks Received =
Parity Errors =
Framing Errors =
Overrun Errors =
```

CHANNEL FORMAT

Each of the Receiver's channels are set up in the following format. These parameters may be changed if needed. Refer to Section 6.4 CUSTOM INTERFACE FORMATTING. The example below is Channel 1 power up default characteristics.

Example:

```
CHAN 1 ON
Channel 1 is ON
Format      = ITIPRT
Lines       = 0
Linefeed    = OFF
Baud        = 2400
Wordsize    = 8
Parity      = OFF
Stopbits    = 2
Control     = HARDWARE
Protocol    = OFF
InProto     = OFF
DSRreq      = ON
CtrlKeys    = OFF
SupChar     = OFF
UnitId      = OFF
AllUnits    = ON
Compress    = OFF
ApndChar    = 00
Ready
```

APPENDIX C EMERGENCY PROCEDURES

The following procedures for handling emergencies are suggested to Central Station owners, managers and supervisors.

In the event of a complete power failure, a RESTART, FULLRESTART or system failure, it is strongly suggested to have a small booklet or checklist entitled "Emergency Procedures in the Event of Receiver Trouble" available for quick reference. If circumstances occur which cause the Receiver to lose its Receiver Options and Channel Settings, these features have to be reset.

NOTE: Even after a FULLRESTART, the Receiver powers up with the ability to receiver calls on all four lines (provided no software or hardware failures occurred).

If you find you are in need of technical assistance call Interactive Technologies, Inc. Technical Service at 800-331-0400 between the hours of 8 A.M. and 6 P.M. CST.

Suggestions for Emergency Procedures Checklist

1. Verify the presence of AC power at the outlet and check Receiver connection.
2. Verify that the backup battery is charged to 12 VDC and is also connected to the Receiver.
3. Verify that the AC fuse is good on the back of the Receiver.
4. Verify that the battery fuse is good on the back of the Receiver.
5. Verify that the Phone Lines are good and plugged in.
6. Verify that the printer and/or computer cables are connected on both ends.
7. Type MSTATUS to see if the above are listed okay.
8. Have a complete and updated MSTATUS report included in the checklist. After performing Step 7, verify that it matches each Receiver Option listed on the MSTATUS report and reset any options that may have changed.
9. You might want to include all or parts of Section 2 INITIAL SET UP and Section 6 INTERFACING PERIPHERAL DEVICES TO THE CS-4000 in the checklist.

It is important to have a correct and up to date hard copy of an MSTATUS report available at all times!

APPENDIX D LEVELS OF OPERATION

PROTECTION LEVELS

The SX-III/IVA, SX-IVB and SX-V systems all have several arming levels. Each needs to be understood.

Level 0 DISARM/CANCEL - (One long beep)

All intrusion sensors off, full time sensors (fire, medical, panic, & environmental) ON.
Full time sensors remain on it levels 0-8.

Level 1 SPECIAL - (One short beep)

Same as Level "0" but Special Intrusion Sensors (silver drawer, gun cabinet, wall safe, etc.) are active and will remain active through level 7.

Level 2 CHIME - (Two short beeps)

Special Intrusion Sensors plus Chime Feature (all exterior sensors will cause 2 chime tones when activated).

Level 3 EXTERIOR - (Three short beeps)

Special Intrusion Sensors plus Perimeter Sensors armed with delays. All interior sensors disarmed. Typically used during daytime or early evenings while at home.

Level 4 AWAY - (Four short beeps)

Special Intrusion Sensors plus ALL OTHER intrusion sensors, both interior and exterior, armed with delays. Typically used when house is unoccupied.

Level 5 SILENT AWAY - (Five short beeps)

Same as level four, but silent. No intrusion sirens would sound. NOT recommended if phone line is vulnerable or when anyone is in the home. Sirens would sound if there was a fire, medical emergency, police panic or if the communicator fails to reach the central station after 3 attempts.

Level 6 NIGHT - (One long & one short beep)

Same as level four, but will disarm pre-selected interior sensors to allow free movement within a portion of the protected interior. Typically used to give a homeowner full access to bedroom - bathroom area at night. Delay times are active.

Level 7 INSTANT NIGHT - (One long & two short beeps)

Same as level six, but entry and exit delay times are instant. Used during night hours after all expected residents have arrived.

Level 8 PHONE TEST - (One long & three short beeps)

This will send a communications test signal over the phone lines to the Central Station. Test is acknowledged at residence either by activation of each siren sound for 2 seconds or a personal phone call from the Central Station Operator.

Level 8 changes to level 0 after successfully communicating to the receiver. If it fails to reach the receiver after eight (8) tries the CPU will display 96 (fail to communicate).

Level 9 SENSOR TEST - (One long & four short beeps)

This level is used to test each sensor (transmitter). The CPU will acknowledge a successful test by first displaying the sensor number reporting in and then removing it from the sensor number display window scroll on the front of the CPU. The sirens connected to the CPU emit a loud "beep" upon activation.

APPENDIX E MISCELLANEOUS WARNINGS AND NOTICES

FEDERAL COMMUNICATIONS COMMISSION (FCC) WARNING

This equipment generates, uses, and can radiate radio frequency energy, and if not installed and used in accordance with the instructions manual, may cause interference to radio communications. It has been tested and found to comply with the limits for a Class A computing device pursuant to Subpart J of Part 15 of FCC Rules, which are designed to provide reasonable protection against such interference when operated in a commercial environment. Operation of this equipment in a residential area is likely to cause interference; in which case the user, at his own expense, will be required to take whatever measures may be required to correct the interference.

IMPORTANT TELEPHONE INFORMATION

Notification to Telephone Company

Upon request, the customer shall notify the telephone company of the particular line to which the connection will be made. It is required that the telephone company be provided with the FCC registration number and the ringer equivalence of the protective circuit.

FCC Registration Number: B4Z 8NW-16726-DT-N

Ringer Equivalence Number: 2.3B

Load Number: 100

Malfunction of the Equipment

In the event that the CS4000 should fail to operate properly, the customer shall disconnect the equipment from the telephone line to determine if it is the customer's equipment which is not working properly, or if the problem is with the telephone company network. If the problem is with the CS4000, the customer shall discontinue use until it is repaired.

Telephone Connection Requirements

Except for the telephone company provided ringers, all connections to the telephone network shall be made through standard plugs and telephone company provided jacks, or equivalent, in such a manner as to allow for easy, immediate disconnection of the terminal equipment. Standard jacks shall be so arranged that, if the plug connected thereto is withdrawn, no interference to the operation of the equipment at the customer's premises which remains connected to the telephone network shall occur by such withdrawal.

Incidence of Harm

Should terminal equipment or protective circuitry cause harm to the telephone network, the telephone company shall, where practicable, notify the customer that temporary disconnection of service may be required; however, where prior notice is not practicable, the telephone company may temporarily discontinue service if such action is deemed reasonable in the circumstances. In the case of such temporary discontinuance, the telephone company shall promptly notify the customer and will be given the opportunity to correct the situation. The customer also has the right to bring a complaint to the FCC if he feels the disconnection is not warranted.

Changes in Telephone Company Equipment of Facilities

The Telephone Company may make changes in its communications facilities, equipment, operations or procedures, where such actions is reasonable required and proper in its business. Should any such changes render the customer's terminal equipment incompatible with the telephone company facilities the customer shall be given adequate notice so the modifications will not interrupt service.

General

This equipment should not be used on coin telephone lines. Connection to party line service is subject to state tariffs.

Ringer Equivalence Number (REN)

The REN is useful to determine the quantity of devices that you may connect to your telephone line and still have all of those devices ring when your telephone number is called. In most, but not all areas, the sum of the REN's of all devices connected to one line should not exceed five (5.0). To be certain of the number of devices that you may connect to your line, you may want to contact your local telephone company.

Equipment Maintenance Facility

Interactive Technologies Inc.
2266 North 2nd Street
North St. Paul, Minnesota 55109
Telephone: (612) 777-2690
WATS: 800-331-0400 (Outside Minnesota)
FAX: (612) 777-5767

APPENDIX F

UNDERWRITERS LABORATORIES INSTALLATIONS

GENERAL - (all applications)

1. The DACR shall be used with either the UL Listed Signaling Device Model DMP106 or LX-810 printers. The printer shall be mounted within 20 feet of the receiver. The Epson LX-810 printer shall employ the INMAC 8214 Surge Protector to protect the AC input.
2. The UL Listed Signaling Device p/n 218600201A keyboard shall be used.
3. The printers shall be connected to a Listed uninterruptable power supply and/or engine driven generator to provide 24 hrs of required backup.
4. A spare receiver and annunciator shall be provided at the Central Station to comply with the requirements of a 30 second replacement.
5. At least two password levels shall be employed. The default master code shall be changed at installation.
6. The "Power Fault" options shall be left "ON".
7. The "Quiet" option shall be "OFF".
8. The "Alert" option shall be "ON".
9. The "Alert Interactive" option shall be "ON".
10. The "Alert Waiting" option shall be "ON".
11. The "Silent" option shall be "OFF".
12. Refer to Section 7.2 for those control units/formats which have been determined compatible by UL.
13. The "TRAP" command shall not be used for UL Listed ITI systems providing Home Health Care Signaling Service.
14. Operation of the CS-4000 DACR with peripherals other than the two printers above has not been investigated by UL.
15. The alarm code conversions shall be made as described in Section 7.2.
16. Connection to other equipment as determined by Underwriters Laboratories as being compatible shall be completed within 20 feet and in the same room as the DACR.

APPENDIX G

COMMANDER PROGRAMMING AND REPORTS

RECEIVING COMMANDER REPORTS

The Command Control Panel communicates to the CS-4000 using the standard ITI format. Calls from the Commander will be displayed the same as calls from an SX-III/IV, SX-IVB or SX-V. All possible reports from the Commander are listed below.

REPORT	DESCRIPTION
01 ALARM!	Zone 1 - Entry Delay Doors
02 ALARM!	Zone 2 - Perimeter Delay Burglary
02 ALARM!	Zone 2 - Perimeter Instant Burglary
03 ALARM!	Zone 3 - Interior Delay Burglary
03 ALARM!	Zone 2 - Interior Instant Burglary
04 ALARM!	Zone 4 - Audible Panic
04 ALARM!	Zone 4 - Silent Panic
04 ALARM!	Zone 4 - Auxiliary
04 ALARM!	Zone 2 - Perimeter Instant Burglary
05 ALARM!	Zone 5 - Fire Zone
05 SUPERVISORY	Fire Zone trouble
77 ALARM! CPU TAMPER	When 10 incorrect codes have been entered.
80 ALARM!	Touchpad Fire Panic
81 ALARM!	Touchpad Police Panic
82 ALARM!	Touchpad Auxiliary Panic
83 PHONE TEST	Initiated by customer, to primary central station.
84 OPENING REPORT User # "N"	When customer disarms the system.
85 CLOSING REPORT User # "N"	When customer arms the system.
86 ALARM! SILENT DURESS	Cannot be cancelled
90 A/C FAILURE	After 4 1/4 hr power failure when panel goes to sleep.
91 LOW CPU BATTERY	When battery voltage drops to 6.5 VDC.
92 ALARM! CPU TAMPER!	When panel is armed and tamper screw is removed.
93 AUTOMATIC TEST	Programmable FOR 1, 7, 28, OR 84 Days.
95 A/C RESTORED	
nn CANCELLED*	Cancels alarm.

***Notes on cancelled Reporting:**

1. Most alarms will stop dialing and will not report if the user enters the access code before the last digit of the phone number is dialed.
2. If an alarm is cancelled after the last digit has been dialed, but before the call to the central station is complete, both an ALARM and a CANCELED report will be received.
3. If an alarm is cancelled after the central station receiver has released the line, but while the sirens are still sounding, Commander will call again and a CANCELLED report will be received.
4. If an alarm is cancelled after the sirens have stopped sounding, no cancelled report will be received.

Exceptions to the above:

1. Silent Panic or Duress alarms will not stop dialing and cannot be cancelled.
2. Fire alarms will not stop dialing but can be cancelled by entering the access code. Always verify a Fire alarm if you receive an ALARM and a CANCELLED report on the same call.

COMMANDER PROGRAMMING COMMANDS

The Commander uses different interactive commands than the SX-II/IV, SX-IVB or SX-V and does not have any GROUP command capability. The list below describes commands necessary to program the Commander. These commands must be preceded by the prefix CM. For example, to program the Touchpad Siren to be silent you would type the command as follows: CM TPSIREN ! <enter>.

<u>OPTION</u>	<u>COMMAND</u>	<u>VALUE/DESCRIPTION</u>
Touchpad Siren	CM TPSIREN	1 = Silent for Intrusion, Police Panic & Tamper 2 = Audible for all the above, (default).
Touchpad Panic	CM TPPANIC	1 = Disabled 2 = Silent 3 = Audible (default)
Touchpad Auxiliary	CM TPAUXILARY	1 = Disabled 2 = Enabled (default)
Touchpad Fire	CM TPFIRE	1 = Disabled 2 = Enabled (default)
Fire Zone Enabled	CM FIRELOOP	1 = Disabled 2 = Enabled (default)
Zone 1 Options	CM PERIM1	1 = Disabled 2 = N/C Delay (default)
Zone 2 Options	CM PERIM2	1 = Disabled 2 = N/C Instant (default) 3 = N/C Delay

<u>OPTION</u>	<u>COMMAND</u>	<u>VALUE/DESCRIPTION</u>
Zone 3 Options	CM INTERIOR	1 = Disabled 2 = N/C Instant (default) 3 = N/C Delay 4 = N/O Instant 5 = N/O Delay
Zone 4 Options	CM PANIC	1 = Disabled 2 = N/O Audible Police Panic (default) 3 = N/O Silent Police Panic 4 = N/O Auxiliary Panic 5 = N/C Instant Intrusion
TouchTone Key Used	CM TTKEY	1 = * Key (default) 2 = # Key
TouchTone Police Panic	CM TTPANIC	1 = Disabled 2 = Audible (default) 3 = Silent
TouchTone Response	CM TTRESP	1 = Slow, 128 milliseconds (default) 2 = Fast, 20 milliseconds
Entry Delay Beeps	CM BEEPS	1 = Soft (default) 2 = Loud 3 = No entry delay beeps
Quick Arm	CM QUICKARM	1 = Disable 2 = Enabled (default)
Automatic Phone Test	CM TEST	1 = Disabled (default) 2 = 1 Day 3 = 7 Days 4 = 28 Days 5 = 84 Days
Dialer Options	CM DIALER	1 = Phone #2 not used (default) 2 = Call phone #2 if phone 1 fails 3 = Call Phone #2 after phone #1
Open/Close Reports	CM OPEN/CLOSE	1 = None (default) 2 = Close Reports only 3 = Open Reports only 4 = Open & Close Reports
Bypass Reporting	CM RPTBYPASS	1 = Disable Bypass Reports (default) 2 = Enable Bypass Reports
AC Power Reporting	CM RPTACPOWER	1 = Disable AC Fail/Restore Reports (default) 2 = Enable AC Fail/Restore Reports

The following commands do not require the prefix CM.

<u>OPTION</u>	<u>COMMAND</u>	<u>VALUE/DESCRIPTION</u>
Entry Delay*	ENTRY	1-9 (10 - 90 seconds) Default = 3
Exit Delay*	EXIT	1-9 (10 - 90 seconds) Default = 3
Timeout	TIMEOUT	1-9 (1-9 minutes) Default = 4
User Access Code	ACCESS	NNN (any four digits, 0-9)
Duress Code	DURESS	NN (Change last two digits of Access code)
Account Number**	ACCT	NNNNN (any five digits, 0-9)
Primary Phone Number	PHONE	7 to 14 digits, including pauses. D = pause
Secondary Phone Number	PHO2	Same as Primary phone number
Supervisory Time	STIME	hh:mm (hh = Hour, mm = Minutes)
Multiple Access Codes***	MACCESS	U NNNN (U - User# 2-6) (N = digit 0-9)
Download to Panel	UPDATE	Sends commands to a trapped panel.
Panel Hang-up & Call back	RECALL	Immediate call back after C.S. release.
Release Panel	RELEASE	Releases a trapped panel.
Manual Line Answer	ANSWER N	N - CS-4000 Phone lines 1,2,3 or 4.
Erase CS RAM Table	ERASE	Clears RAM IMAGE TABLE in CS-4000.
Trap a Panel	TRAP NNNNN	NNNNN = 5 digit Account Number.
Disable Trap	TRAP OFF	Except account # 00-000 which always traps.

* Entry and Exit Delay values are 1/10 the actual time. For example, to program an Entry Delay of 4- seconds you would type the following: ENTRY 4 <entry>. When the Entry and Exit times are displayed on the CS-4000 screen, the value numbers will be followed by (x10).

** Commander will not accept alphabetical characters as part of its Account number.

*** The Commander has five additional codes besides the Master and Duress codes. These codes do not have any HI or LOW status. For example, to program the access code 1492 for User #3 you would type the following: MACCESS 3 1492 <enter>.

APPENDIX H

ITI COMPUTER OUTPUT FORMAT

HISTORICAL

The ITICOMP output format was designed to pass information out one of the RS-232 channels of the CS-4000 in a generalized form. This information can then be used by Computer Monitoring Systems.

ITICOMP provides the most information of any output format supported by the CS-4000. It was designed as a more generalized form of the GENERIC output format introduced by ITI in 1985. While the GENERIC format provides basic information about each alarm called in, the ITI central station and alarm panels have enough intelligence to communicate more detailed information as well. The ITICOMP output format was born out of a desire to respond to many individual customer requests for specific pieces of extra information. In order to accommodate future requests for additional data the format was designed to be as flexible as possible. Records are of variable length, and information fields may be added as additional needs arise.

GENERAL

Each ITICOMP record is a collection of fields of undefined length. Each field begins with a vertical bar character ("|", ASCII character 7C hex). This is followed by a field identifier character, and then one or more characters of data. In the default form of ITICOMP, all data are ASCII printable characters. (If the "Channel SupChar" option is turned off, however, |[O records may contain embedded ANSI escape sequences.)

Each record begins with a "|[" record type field, and ends with a "|]" checksum/control field. Any other fields are included as needed or left out if unused. Aside from "|[" and "|]", field identifiers are only guaranteed to be unique within a given record type - that is, the same field identifier character can have different meanings depending on the type of the record in which it is found. For example, the |L field in a |[T test record has a different meaning than the |L field in a |[R report record.

Within a record, there is no guarantee as to the order of the information fields except for the first (record type) and last (checksum/control) fields. At the end of the checksum/control field, each record is terminated with a carriage return (ASCII 0D hex).

RECORD TYPES

Currently there are six main record types:

[R	Report records
[P	PTIME records
[T	Print test records
[S	Supervision records
[O	Remote output records
[I	Remote input records

To be added in a future software release:

[L	Phone log records
[R	Report Records

A report record is generated whenever an alarm panel calls in with any sort of information. Report records correspond roughly to the records generated by the GENERIC output format, but more detail is provided. Following is a sample report record, as well as an explanation of fields that may be found in a report record:

```
| [R|IA0|L0|APE123|P04|V55600|GDA|D0108|T1620|N893|Z85|CC|U0| ]U8DFA
```

- | I CS-4000 identification - this is typically followed by two characters, corresponding to the unit id (set by the UNIT command) and the receiver id (set by the RID command).
- | L Phone line identification - this is followed by a number from 0-4, identifying the phone line on which the call arrived (line 0 is the front CPU jack).
- | A Account number - typically three to six alphanumeric characters.
- | P Protection levels - this is followed by two single-digit numbers, indicating respectively the previous and current protection levels of the alarm system.
- | V Panel type/version - for non-ITI panels this is followed by a one-character identifier only. For ITI panels a one-character panel identifier is followed by four digits of revision level information.
- | G Group/attribute information - this is followed by two hex digits of coded information about the group code and attributes of the reporting zone.
- | D Date of report, in form mmdd.
- | T Time of report, in form hhmm.
- | N Report sequence number, a one- to four-digit number.
- | Z Zone number, also one to four digits.
- | U User number - a single-digit number, typically associated with opening and closing reports.
- | S CPU Sub-unit number - a single-digit number typically used to report hardware supervisories.
- | C Condition code - a one-character code indicating the nature of the alarm, as follows:
 - | CA Alarm!
 - | CB Bypassed sensor
 - | CC Closing report
 - | CE Exit fault
 - | CF Force arm/Auto force arm
 - | CL Low battery
 - | CO Opening report
 - | CP Power failure (currently non-ITI panels only)
 - | CR Restoral of sensor
 - | CS Supervisory (including zone 94 receiver failure)
 - | CT Tamper
 - | CU Status report (currently non-ITI panels only)
 - | CX Cancel
 - | CZ Phone test

To be added in a future software release:

```
| CJ Trouble
```

Note that this list is current but not final. ITI reserves the right to add additional Condition Codes as the need arises.

| [P PTIME Records

A PTIME record is generated when an ITI panel calls in an alarm and the CS-4000 has the PTIME feature turned on. The PTIME feature causes panels in alarm to report how long ago their current protection level was set. Each time the PTIME message ("Set dd Days hh Hours mm Mins Ago") is displayed on the central station CRT, ITICOMP format will send a PTIME record. Following is a sample PTIME record, as well as a description of the fields it can contain:

```
| [P | IAO | L0 | APE123 | P04 | V55600 | D0108 | T1630 | N909 | E000001 | ] UDEB3
```

- | I CS-4000 identification - same as in report record
- | L Phone line identification - same as in report record
- | A Account number - same as in report record
- | P Protection levels - same as in report record
- | V Panel type/version - same as in report record
- | D Date of report - same as in report record
- | T Time of report - same as in report record
- | N Report sequence number - same as in report record
- | E Elapsed time since current protection level was set in days, hours, and minutes - six digits of information in form ddhhmm

| [T Print Test Records

A print test record is generated when the print test key (function key F9) is pressed on the CS-4000 keyboard. If the STAMP feature is turned on (which is the default), a print test record will also be generated every hour on the hour. A sample print test record, along with a description of the fields it contains, follows:

```
| [T | IAO | D911004 | T152824 | V010191 | L3.2 | ] RDA93
```

- | I CS-4000 identification - same as in report record
- | D Current date - six digits in format yymmdd. Note that the first two digits are the year.
- | T Current time - six digits in format hhmmss.
- | V Software version date - six digits in format mmddyy. Note that the last two digits are the year.
- | L CS-4000 revision level - typically two digits and a decimal point.

| [S Supervision Records

A supervision record is generated when the automation computer checks the CS-4000 for a pulse via the RS-232 interface. The computer does this by transmitting a previously defined "supervisory character" to the CS-4000. The supervisory character is determined through the "SupChar" option setting for the output channel connected to the computer through ITICOMP. The default supervisory character is a question mark ("?", ASCII 3F hex). The fields for a supervision record are exactly the same as those for a print test record; the only difference is that for a supervision record the record type is | [S instead of | [T.

||O Remote Output Records

If the supervision character is disabled (Channel n SupChar option turned OFF), a general output record will be generated for every line displayed in the CS-4000 "scroll of events" window. An output record consists of the record type field, a |I field containing only a one-character unit id, a |> field, and the checksum/controls field. The |> field contains the full text of the line displayed. The |> field within a ||O record is the only ITICOMP field that may contain non-printable ASCII characters, as it sometimes contains escape sequences used to produce inverse video, boldface, and flashing text. In such cases, the escape sequences sent are those specified in the ANSI X3.64 standard. These records are only generated on ITICOMP channels whose SupChar option has been turned off. A typical remote output record looks like this:

```
||O|IA|>Ready|]T089F
```

||I Remote Input Records

When the supervision character is turned off (Channel n SupChar OFF), input records may also be sent from the computer to the CS-4000. These have the same format as output records, except that the record type is ||I and no escape sequences are allowed in the |> field. The |> field may contain any CS-4000 command, which will then be executed. Software generating ||I remote input records must end them with a correct checksum/control field. Any ||I record received with improper checksums will be ignored. The sequence control character of a remote input record is independent of the sequence of output records, and sequence continuity must be maintained among all input records. That is, if the sequence control character on the first input record sent is F, the sequence character on the next input record must be G, etc.

||L Phone Log Records - (to be included in a future release of CS-4000 software). A future release of CS-4000 software will have the ability to encapsulate all report records generated by a phone transaction with a pair of phone log records. A CS-4000 feature called COMPLOG will be turned on or off depending on if log records are desired. Note that this feature is not available with the 1/1/91 software release; this information is intended solely to help developers prepare for the future. The log records and report record generated by a sample alarm call are shown, as well as an explanation of the fields of the log records:

```
||L|IA0|L1|N1|S901106193100|]B969B
|[R|IA0|L1|AALLEN|P58|VR2500|G3K|D1106|T1931|N1|Z1|CA|]D2B6
|[L|IA0|L1|N1|E901106193110|]E8C8B
```

The following fields are found in the log records:

- |I CS-4000 identification - same as in report record
- |L Phone line identification - same as in report record
- |N Report sequence number - same as in report record
- |S Start stamp record of date and time of start of phone call in format YYMMDDhhmmss
- |E End stamp record of date and time of termination of phone call in format YYMMDDhhmmss

CHECKSUM/CONTROL FIELD

The last field on every record is the |] checksum/controls field. This field contains an upper case letter followed by four hexadecimal digits. Encoded in these five characters are three controls to help guarantee data integrity between the receiver to the computer.

The first control is the sequence control character. This is a letter code which cycles from A to Z over and over again, being incremented for each new record transmitted. Note that if the receiver repeats a record in response to a NAK character from the computer the same sequence control character is sent both times.

The first two hexadecimal digits following the sequence control character are the two least significant digits of an additive checksum of the record. This checksum is computed by adding the ASCII values of all bytes in the record from the first | character up to and including the sequence control character.

The last two hex digits in the record are an XOR checksum. The XOR checksum starts with a value of FF. This value is XORed against the first byte in the record; the result is XORed against the next byte; and so on up through the sequence control character.

The checksum computations are illustrated here on a short fake record consisting only of | [X :

| [X] A 4 9 E 0

Character	ASCII Code	Additive Checksum	XOR Checksum
	7C	00 + 7C = 7C	FF ^ 7C = 83
[5B	7C + 5B = D7	83 ^ 5B = D8
X	58	D7 + 58 = 12F	D8 ^ 58 = 80
	7C	12F + 7C = 1AB	80 ^ 7C = FC
]	5D	1AB + 5D = 208	FC ^ 5D = A1
A	41	208 + 41 = 249	A1 ^ 41 = E0

ANTICIPATED FLOW OF EVENTS FOR THIS FORMAT

We anticipate that the following sequence of steps would occur with a computer package receiving ITICOMP format records.

1. Accumulate/Receive the entire record at the computer and verify the checksum/control field. If either checksum is wrong, send a NAK (ASCII 15 hex) to the receiver so it resends the record. If the checksums are correct an ACK (ASCII 06 hex) character could be sent right away, but it is recommended that the data in the current record be fully processed first. The CS-4000 will wait 20 seconds for the ACK; by not sending it until ready for the next record, data flow out of the receiver can be paced. Check the sequence control character. If this character is out of sequence, notify the operator that "data has been lost." This could be a very serious error!
2. Examine the record type field. If the record type is unknown, the operator should be warned of an exception (new record types will be added in future software releases). If the record is of a known type but will not be used, don't forget to send the required ACK to the CS-4000.

3. Parse the other fields in the record and store any useful data. Once again, any unknown field should be displayed to the operator as an exception, as should the absence of any expected field. Note that not all fields listed for the report record will be present in every record. For example, some non-ITI panels have reports with no associated zone number; in such a case the |Z field is omitted.
4. Process the data received as desired.
5. Respond with an ACK character to the receiver to indicate that the last record sent has been satisfactorily processed.

ADDITIONAL NOTES

Note that |[L records and |CJ condition codes are not available in the 1/1/91 software release. As of the 1/1/91 software release, |[L records are output correctly only for a specific vendor's panels, so COMPLOG should never be turned on. In the future |[L records will be available for all ITI panels.

It is very important to be as flexible as possible when processing ITICOMP records. The data contained in a given field may change slightly with time. For example, the |V field in the report record used to give a three-character panel type/version code. As of the 1/1/91 CS-4000 software release, though, the |V field can contain up to five characters of panel type/version information. Most ITI account numbers, reported in the |A field of report or PTIME records, are currently five characters long; some may be six characters long in the future. The broader the assumptions made about data in information fields, the smoother the transition to future versions of ITICOMP. ITI reserves the right to add or change fields as needed.

APPENDIX I

RF COMMANDER PROGRAMMING AND REPORTS

RECEIVING RF COMMANDER REPORTS

The RF Command Control Panel communicates to the CS-4000 using the standard ITI format. Calls from the RF Commander will be displayed the same as calls from an SX-III/IV, SX-IVB or SX-V. All possible reports from the RF Commander are listed below.

<u>REPORT</u>	<u>DESCRIPTION</u>
00 ALARM!	Auxiliary (Freeze sensor)
01 ALARM!	Fire Sensor
02 ALARM!	Fire Sensor
03 ALARM!	Fire Sensor
04 ALARM!	Perimeter Delay
05 ALARM!	Perimeter Delay
06 ALARM!	Instant Perimeter
07 ALARM!	Instant Perimeter
08 ALARM!	Instant Perimeter
09 ALARM!	Instant Perimeter
10 ALARM!	Instant Perimeter
11 ALARM!	Instant Interior
12 ALARM!	Instant Interior
13 ALARM!	Instant Interior
14 ALARM!	Audible Police Panic (unsupervised)
15 ALARM!	Silent Police Panic (unsupervised)
16 ALARM!	Audible Auxiliary Panic (unsupervised)
80 ALARM!	Touchpad Fire Panic
81 ALARM!	Touchpad Police Panic
82 ALARM!	Touchpad Medical Panic
83 PHONE TEST	Initiated by customer, to primary central station.
84 OPENING REPORT User # "N"	When customer disarms the system.
85 CLOSING REPORT User # "N"	When customer arms the system.
86 ALARM! SILENT DURESS	Cannot be cancelled
87 ALARM!	Forced Arm Auto / Forced Arm

REPORT	DESCRIPTION
90 ALARM!	AC Failure
91 ALARM!	Low CPU Battery
92 ALARM!	CPU Tamper
93 ALARM!	Automatic Phone Test
94 ALARM!	Receiver Failure / Invalid Sensor
95 ALARM!	CPU back in service

***Notes on cancelled Reporting:**

1. Most alarms will stop dialing and will not report if the user enters the access code before the last digit of the phone number is dialed.
2. If an alarm is cancelled after the last digit has been dialed, but before the call to the central station is complete, both an ALARM and a CANCELED report will be received.
3. If an alarm is cancelled after the central station receiver has released the line, but while the sirens are still sounding, RF Commander will call again and a CANCELLED report will be received.
4. If an alarm is cancelled after the sirens have stopped sounding, no cancelled report will be received.

Exceptions to the above:

1. Silent Panic or Duress alarms will not stop dialing and cannot be cancelled.
2. Fire alarms will not stop dialing but can be cancelled by entering the access code. Always verify a Fire alarm if you receive an ALARM and a CANCELLED report on the same call.

RF COMMANDER PROGRAMMING COMMANDS

The RF Commander uses different interactive commands than the SX-II/IV, SX-IVB or SX-V and does not have any GROUP command capability. The list below describes commands necessary to program the RF Commander.

OPTION	COMMAND	VALUE/DESCRIPTION
Entry Delay	ENTRY	1-9 (10 - 90 seconds) Default = 3
Exit Delay	EXIT	1-9 (10 - 90 seconds) Default = 3
Timeout	TIMEOUT	1-9 (1-9 minutes) Default = 4
User Access Code	ACCESS	NNN (any four digits, 0-9)
Duress Code	DURESS	NN (Change last two digits of Access code)

<u>OPTION</u>	<u>COMMAND</u>	<u>VALUE/DESCRIPTION</u>
Account Number	ACCT	NNNNN (any five digits, 0-9)
Primary Phone Number	PHONE	7 to 14 digits, including pauses. D = pause
Secondary Phone Number	PHO2	Same as Primary phone number
Supervisory Time	STIME	hh:mm (hh = Hour, mm = Minutes)
Multiple Access Codes*	MACCESSN	U NNNN (U - User# 2-6) (N = digit 0-9)
	MACCESS2	Visitor access code (any 4 digits)
House Code	HOUSENNN	001 - 254 (default 000)
Initialize Sensors	INITIALIZENN	NN = 00-16, 84-87, 90-96 (default 80-83, 86,87,91,92,94-96 on)
Delete Sensors	DELETENN	NN = 00-16, 84-87, 90-96 (default 80-83, 86,87,91,92,94-96 on)
Bypass Sensor	BYPASSNN	NN = Sensor # 00, 04-16 (default = none)
Protection Level	PLEVELN	N = 1-7 (default = none) <i>NOTE:</i> The protection level shall not be remotely changed in U.L. listed applications.
Automatic Phone Test	PTFREQN	N = 1-255 days (default 35 days) <i>NOTE:</i> In U.L. listed applications, this action shall be programmed for 1 day.

* The RF Commander has five additional codes besides the Master and Duress codes. These codes do not have any HI or LOW status. For example, to program the access code 1492 for User #3 you would type the following: `MACCESS 3 1492 <enter>`



APPENDIX J

SOFTWARE RELEASE VERSION 3.2 01/01/91

This appendix explains the software and hardware changes in your CS-4000 part number 60-197-64K software version 3.2 1/1/91. The hardware change is an internal memory expansion. The software has been changed to support the RF Commander panel. There are also other software changes that are explained.

HARDWARE CHANGE

The internal memory has been expanded from 32K, to 64K of RAM. This increase of internal memory is needed to run the new 3.2 1/1/91 software.

NEW PANEL

Full support has been added for the RF Commander panel.

MODIFIED COMMANDS

MACCESS

This command has been modified to accommodate panels with varying numbers of multiple access codes. Below are the valid values for each panel.

SX -V: (1-10)

RF Commander & Commander: (2-6)

OEM RF Commander: (2)

Note: The only panel which modifies levels for the access codes is the SX-V.

LOW BATTERY

The SX-V now reports **Low Battery's** as **Trouble's**. This change only affects the CS-4000 display, i.e. the output formats remain unchanged.

CHANNEL

The channel command has been modified to accommodate the new EPSON printer format. The new command is: CHANNEL FORMAT EPSON This command configures the channel to the default settings required by the Epson LX-810 printer. See the "New CS-4000 Printer" section (on back) for more information.

SUPSYNC

This command has a new format: SUPSYNC <n> Where <n> is the number of hours between the calculating of supervisory conditions in the panels. Earlier versions of this command also incorporated a <time> field. This field has been removed to alleviate redundancy between this command and the STIME command.

OTHER 1

Other 1 command level has been changed to a high level CS-4000 command.

OBSOLETE COMMANDS

Three commands have been replaced (effectively renamed):

TIMEOUT - siren timeout command replaced by ----- SIREN.
 PORTS - ports (zones) dump command replaced by ---- ZONES.
 ONLINE -online/phones command replaced by ----- PHONE.

Attempting to use these commands results in directing the user to apply the new command. Simply "Obsolete Command, see..."

NEW COMMANDS**CPUTYPE <on/off>**

Allows the user to select whether or not to display the calling panel's CPU type. Presently, only if a panel is trapped does it display the CPU type. This feature is available for all panels regardless of the trap status. Default is set to off.

COMPLOG <on/off>

Is an engineering test mode used for future software development related to ITICOMP format. This command is not compatible with current automation software. Do NOT turn on. Default set to OFF.

RF COMMANDERS

Two versions of the RF Commander are supported by this release of the CS-4000. These two variations are the O.E.M. Commander and the RF Commander. When these panels report and identify themselves (either by being trapped or via the CPUTYPE command), the revision level of the panel is displayed. The O.E.M. Commanders are identified by revision levels 2.1, through 2.4. The RF Commanders have revision levels starting at 2.5. An example of each display:

CPU is an RF Commander v2.3 - a O.E.M. Commander
 CPU is an RF Commander v2.5 - an ITI RF Commander

We need to distinguish between each panel because, at this time, the O.E.M. Commander's programming is a subset of the RF Commander's programming. The panels differ by three commands - MACCESS, PHONE2, and STIME.

Below is a list of Interactive CS-4000 commands that can be used to program the RF Commanders:

ACCESS, ACCOUNT, BYPASS, DELETE, DURESS, ENTRY, EXIT,
 HOUSE, INITIALIZE, MACCESS*, PHONE, PHONE2*, PLEVEL,
 PTFREQ, RESTORE, SIREN, STIME*, ZONES.

Note: An * means that this command differs between the two different variations. Here are the differences:

MACCESS <user> <code> -differ in the <user> field.
 <user> -2 is the only valid entry on the O.E.M. version.
 -2-6 are valid on the RF Commander.
 PHONE2 <number> - Not valid on the O.E.M. Commander.
 STIME <time> - Not valid on the O.E.M. Commander.

Note: The multiple init, delete, group commands (MINIT, MDELETE, MGROUP) are not available with the R.F. Commander panels.

NEW CS-4000 PRINTER

A new printer needed to be UL listed for use with the CS-4000. The CS-4000 manual currently suggests using the Tandy DMP-106 printer from Radio Shack. The CS-4000 is UL 1610 listed with the DMP-106 printer. But, Radio Shack has discontinued production of the DMP-106. The new printer is the EPSON LX-810. This printer was sent to UL for testing with the CS-4000. Using this printer in conjunction with a surge protector passed UL. A write-up from UL is forthcoming. This is the printer we suggest you use.

Please note that the CS-4000 accessory kit (part 59-045) has been changed to reflect the new printer. With previous versions, the kit included a special printer cable designed to work with the Radio Shack printers. This cable is no longer being included. In its place is another "terminal" style cable.

IMPORTANT: On power-up, channel one on the CS-4000 now defaults to format EPSON instead of ITIPRT. The default settings of the format EPSON are tailored to work well with the Epson LX-810 printer. Customers still using the Radio Shack DMP-106 printer will have to issue an additional command on power-up to correctly configure the channel as before. Type: CHANNEL 1 FORMAT ITIPRT

APPENDIX K

SOFTWARE RELEASE VERSION 3.2 06/06/90

This appendix explains the software and hardware changes in your CS-4000 to software version 3.2 06/06/90.

Changes in this version of software are:

- The garbled alarm message “**Protection Level Was — Now —**” will not occur: In all data communication systems, the possibility of data being garbled by outside forces is an everyday concern. ITI recognizes this situation and has implemented a change in the CS-4000 software that will reduce, if not eliminate, the possibility of garbled alarm messages from our CPUs. This new software has been restructured to include tighter data analysis and error detection routines.
- ‘**xx Alarm Tamper**’: The information displayed for a tamper condition from a door/window sensor (when the cover is removed after sensor has been tripped) will now show ‘**xx Alarm Tamper**’, instead of ‘**xx Exit Fault**’.
- The start-up banner message has been modified.



APPENDIX L

SOFTWARE RELEASE VERSION 3.2 10/15/89

This document contains a listing with explanations of revisions in software version 3.2, 10/15/89. This is the latest software version available for the CS-4000. To determine which software version you currently have, simply type the command VERSION <enter>.

1. **4/2 Format:** Correctly converts zone information to the "English" table.
2. **COMMANDER PANELS:** Full support. Complete list of Interactive Commands available the week of 11/13/89.
3. **QUIET ON/QUIET OFF:** With the QUIET feature set either to ON or OFF, the Radionics Computer Format works correctly.
4. **SX-V EVENT BUFFER:** This feature now abbreviates LOW BATTERY as LOW BATT and SUPERVISORY as SUP when displaying events.
5. **EVENT COMMAND:** This command no longer requires that you type EVENT ALL. By entering EVENT, the CS-4000 will display all 64 events in the SX-V buffer. EVENT "nn" (where nn = the number of events to be reviewed) still works as before.
6. **SIREN COMMAND:** This command will eventually replace the TIMEOUT command. Both commands are available and operate the same. Help screens have been updated to display both commands.
7. **MACCESS COMMAND:** The format for entering Multiple User Codes 1-10 has been changed for the SX-V and Commander. These codes are now set and displayed as follows:
 - MACCESS (1-10) (CODE) (HI/LOW) for SX-V.
 - MACCESS (2-6) (CODE) for Commander.
8. **HELP SCREENS:** Now display the correct commands. Previous versions displayed some invalid commands.

Version 3.2 also contains the revisions listed below, which were previously released in earlier software versions.

1. **EXPAND ON/EXPAND OFF:** With this feature ON, the receiver will identify the type of panel (SX-IVB or SX-V) it is communicating with. If this feature is OFF, the CPU type will not be displayed.
2. **GENERIC COMPUTER FORMAT:** This format now outputs the user access codes 0-33 as follows: 0-9 as 0-9, and 10-33 as A-W.
3. **PLEVEL COMMAND:** This command is fixed. In some earlier software versions the CS-4000 would sometimes terminate calls as soon as the command was executed.
4. **CPUTIME SET COMMAND:** This command now correctly sets and displays the time of the SX-V CPU clock.
5. **EVENT COMMAND:** This command now displays the correct date and time of the events listed, provided the SX-V CPU clock was correctly set.
6. **ANSWER "n":** When ANSWER "n" (n = line 1,2,3 or 4) is entered to manually answer a CPU, the handshake tone has been extended to 20 seconds. This will allow the CS-4000 a better chance to answer the CPU, especially if the CPU has a phone number programmed into its memory and you typed ANSWER 1<enter> before the CPU completed dialing.
7. **AUTO FORCE ARM REPORT:** This command now reports the AUTO FORCE ARM condition correctly. For example, if sensor 34 is open when the customer attempts to arm the system, it causes the CPU to protest. If the customer mistakes the protest sound for the arming sound, doesn't bypass sensor 34, then leaves with the sensor open, the SX-V CPU will automatically bypass open sensor 34 and arm the system to the level of protection the customer selected, after the TIMEOUT period has expired. In the past this would report 87 SUPERVISORY instead of 87 AUTO FORCE ARMED. This version will display the report as follows:

```
87 AUTO FORCE ARMED
34 BYPASSED
```
8. **PLUS SIGN (+):** The plus (+) sign can be used to suppress the automatic STATUS feature when using the CHANNEL, LEVEL, MACCESS, XACCESS and OPTION commands. For example, the commands would be entered as follows:

```
CHANNEL 1 DSRREQ OFF + <enter>
MACCESS 3 LOW 4321 + <enter>
```
9. **HELP MESSAGE TIMEOUT ERRORS:** An automatic HELP message has been added for both DSR and ACK TIMEOUT ERRORS to help explain what happens when these occur.

APPENDIX M

Software Release Version 4.0 6/15/92

Including added commands for CareTaker Plus CPU

This document describes the enhancements made in software version 4.0, 06/15/92 for the CS-4000. This software version includes full support for the ITI CareTaker Plus control panel.

IMPORTANT! This software version will not work on a CS-4000 that does not have 64K of RAM. Make sure the part number on your CS-4000 is 60-197-64K before attempting to install this software. If you do not have 64K, contact ITI for an upgrade.

Below is an explanation of changes affecting RF Commanders. The following pages include a complete list of CS-4000 reports and commands for CareTaker Plus. Concluding this document is a description of commands which affect the operation and/or displayed information of the CS-4000 itself.

IMPORTANT! Before installing this software perform an MSTATUS command to obtain a printout of the CS-4000's current settings. If you are using the E31, E3X, E41 and E42 options be sure to get a printout of those settings also.

ITI RF Commander (with software version 2.5 and later)

RF Commanders now allows sensor re-grouping using the standard CS-4000 GROUP command. The default group settings for RF Commander sensors are listed below. Example: To change sensor 10 from the Intrusion group to the Fire group you would type: GROUP 10 02 D<enter>

SENSOR#	GROUP#	GROUP NAME	ACTIVE LEVELS
00	01 L	Freeze Sensor	1-3
01-03	02 D	Fire Sensor	1-3
04-05	04 L	Entry/Exit	2-3
06-10	05 L	Perimeter Instant	2-3
11	06 L	Interior Instant (F)*	2-3
12-13	06 I	Interior Instant (F)*	3
14	00 A	Audible Police Panic	1-3
15	12 A	Silent Police Panic	1-3
16	01 B	Audible Aux. Panic	1-3

* (F) indicates Follower. Sensors in this group will not trip an alarm if a delay group sensor is tripped first.

NEW COMMAND: BATTLIFE n (n = 1 to 30 hours)

The RF Commander's default BATTLIFE is 4 to 5 hours. When there is an AC power loss for more than 4 to 5 hours the RF Commander shuts down. With the BATTLIFE command the 4 to 5 hour default setting can be reduced or expanded from 1 to 30 hours. When using an Alkaline back-up battery a setting of 4 hours is recommended to allow for several power loss routines without replacing the battery each time. If using the Nicad battery pack a setting for up to 30 hours can be used. *NOTE*, the actual battery life of the Nicad battery pack is approximately 12 hours.

NOTE: BATTLIFE command is valid on ITI RF Commander's with software version 2.6 and later. On software version 2.5 the BATTLIFE command will have no effect. On software versions older than 2.5 BATTLIFE command is invalid.

CareTaker Plus Alarm Reports

Below is a description of all possible reports from a CareTaker Plus control panel.

- | | |
|-----------|---|
| 01 ALARM! | 77 Alarm! Touchpad Tamper/Supervisory |
| 02 ALARM! | 78 Trouble/Freeze! |
| 03 ALARM! | 79 ALARM! (No Activity) |
| 04 ALARM! | 80 ALARM! (Touchpad Fire) |
| 05 ALARM! | 81 ALARM! (Touchpad Police) |
| 06 ALARM! | 82 ALARM! (Touchpad Auxiliary) |
| 07 ALARM! | 83 Phone Test |
| 08 ALARM! | 84 Opening Report User 0-6 |
| 09 ALARM! | 85 Closing Report User 0-6 |
| 10 ALARM! | 86 ALARM! (Silent Duress) |
| 11 ALARM! | 87 FORCED ARMED/AUTOFORCE ARMED |
| 12 ALARM! | 88 Trouble (Energy Saver) |
| 13 ALARM! | 89 Trouble (RF Touchpad Low Battery or Supervisory) |
| 14 ALARM! | 90 AC Power Failure or Power Supply Failure |
| 15 ALARM! | 91 Low CPU Battery |
| 16 ALARM! | 92 ALARM! (CPU Tamper) |
| 17 ALARM! | 93 Auto Phone Test |
| 18 ALARM! | 94 Receiver Failure |
| 19 ALARM! | 95 CPU Back In Service |
| 20 ALARM! | |
| 21 ALARM! | |
| 22 ALARM! | |
| 23 ALARM! | |
| 24 ALARM! | |
| 25 ALARM! | |
| 26 ALARM! | |
| 27 ALARM! | |
| 28 ALARM! | |
| 29 ALARM! | |
| 30 ALARM! | |
| 31 ALARM! | |
| 32 ALARM! | |

NOTE: Some sensor and/or zone numbers report a cancel to the central station when the system's arming level is changed.

NOTE: Sensor numbers 01-32 may also report as Low Battery, indicating a low sensor battery, or supervisory indicating transmitter trouble.

NOTE: Hardwire zones from 01-32 may also report as Trouble, indicating a cut or shorted line condition of the reporting zone.

CareTaker Plus Programming Commands

The following commands are used to program the CareTaker Plus control panel from the CS-4000.

FEATURE	COMMAND	VALUE/ENTRY	DEFAULT
Primary Access Code	ACCESS nnnn	Any 4 digits	1234
Visitor Access Code	MACCESS 1 nnnn	Any 4 digits	None
Multiple User Codes	MACCESS n nnnn	n = user# 2-5 nnnn = 4 digit code	None
Duress Code	DURESS nn	Any 2 digits.	None
Account Number	ACCT nn- <u>nn</u>	Any 5 digits, letters or combination of both.	00-000
Primary Phone#	PHONE	Up to 18 digits (Enter D for pauses.)	None
Secondary Phone#	PHONE2	Up to 14 digits (Enter D for pauses.)	None
Phone Format	PFORMAT n	0 = ITI Format 1 = 4/2 Format, 1400Hz. HS 2 = 4/2 Format, 2300Hz. HS	0
Siren Timeout	SIREN n	1-15 (minutes)	4
House Code	HOUSE nnn	nnn = 000-255	000
Entry Delay	ENTRY s e	s = standard delay, 8-88 sec. e = extended delay, 1-8 min.	32 4
Exit Delay	EXIT nn	8-88 (seconds)	32
Activity Timeout	ACTIVITY n	1-24 (hours)	24
Energy Saver Freeze	FREEZE nn	40-90 (°F)	42
Energy Saver Hi/Low Temperature Set	ENERGY ll hh	ll = low temp 45-90 (°F) hh = high temp 45-90 (°F)	None
Initialize Sensors	INIT nn	Upper Sensors 77-96	
Delete Sensors	DELETE nn	Any sensor from 01-32, 77-96.	None
Bypass Sensors	BYPASS nn	Any sensor from 01-32.	None
Supervisory Time	STIME hh:mm	00:00-23:59	00:00
Protection Level	PLEVEL n	n = 1-3, 8-9	None
Auto. Phone Test	PTFREQ N n	N = 1-255 (days in cycle) n = 1-255 (days left in cycle)	7 7
F Options	OPTION Fnn ON/OFF	Fnn = F00-F07 & F11-17	None
Zone Dump	ZONES or ZONES nn nn	Low sensor# & High sensor#	None
Dialback To C. S.	DIALBACK nnnn	nn = 10 - 2,550 min. (in 10 minute increments)	None

FEATURE	COMMAND	VALUE/ENTRY	DEFAULT
Phone Mode	PMODE n	n = 0 only primary phone no. is dialed. n = 3 first phone reports all alarms, openings and closings 2 nd phone no. reports everything. Both phone numbers are ITI format. n = 5 same as PMODE 3 except first phone is 4/2 format	0

IMPORTANT: PMODE command overrides PFORMAT command; for example, if PFORMAT 0 is initialized and PMODE 5 is initialized, the first phone number will be in 4/2 format.

CareTaker Plus F Options

OPTION	DEFAULT	DESCRIPTION
F00	ON	Remote Phone Access
F01	ON	Ring - Hang-up, Ring - Answer
F02	ON	Exterior Siren Delay (ON = 15 Second Delay; OFF = No Delay)
F03	ON	Toll Saver
F04	ON	Low Battery Reports (ON = Weekly; OFF = Daily)
F05	ON	Supervisory Reports (ON = Weekly; OFF = Daily)
F06	ON	Dialer Abort
F07	OFF	Access Key Type (OFF = *; ON = #)
F11	OFF	Interior Siren Sounds (OFF = Alarms & Status; ON = Alarms Only)
F12	OFF	Alarm Restoral Reports
F13	OFF	Low Battery Restoral Reports
F14	OFF	Hourly Phone Test
F15	OFF	Alarm Verification
F16	OFF	Trouble Beeps
F17	OFF	Sensor Tamper

New Non-Interactive Commands

The following commands determine how some information will be displayed and sent out the RS-232 ports (Channels 1, 2 & 3) by the CS-4000.

COMMAND	DEFAULT	DESCRIPTION
ATTEMPTS ON/OFF	OFF	Set the CS-4000 to display the number of previous dialing attempts when a CPU reports. When set to ON, the previous dialing attempts of reporting SX-V and RF Commander control panels will be displayed.

NOTE: This command slightly lengthens the total transaction time before displaying any information when a control panel reports to the CS-4000.

COMMAND	DEFAULT	DESCRIPTION
COMPLOG ON/OFF	OFF	Set whether or not the CS-4000 will display I[L records in the ITICOMP format.
SUPERACK ON/OFF	OFF	Set the action taken by the CS-4000 upon receiving an ACK character on an RS-232 port (Channel 1, 2 or 3) set to the ITICOMP format. If PROTOCOL of the ITICOMP channel is ON, the CS-4000 expects to receive an ACK character in response to every ITICOMP record sent out. With SUPERACK OFF, the ITICOMP channel acknowledges a record was received and allows the CS-4000 to send the next record when one is available. With SUPERACK ON, ACK records received in response to I[R report records also cause the CS-4000 to behave as if the operator pressed the SILENCE and F2 (Report Acknowledge) keys.
DISPLAY option ON/OFF	STANDARD ON	Set the CS-4000 to display the desired CPU programming commands when the COMMANDS command is entered. The STANDARD setting will display the basic programming commands for SX-III, SX-IVB and SX-V CPUs. To display CareTaker Plus programming commands, type: DISPLAY CT+ ON<enter>. To display Commander and RF Commander programming type: DISPLAY CMNDR ON <enter>.
REVLEV ON/OFF	OFF	Set whether or not the CS-4000 will display the software revision of any reporting ITI control panel.

IMPORTANT:

The following command is set at the factory before shipping the CS-4000 to its destination. The settings for the RNGCAD command should not be changed unless the CS-4000 is to operate through a PBX phone system with a non-standard ring cadence.

Units shipped overseas from the United States are also pre-set. Again, changing the RNGCAD is not necessary unless the CS-4000 experiences difficulty receiving reports from control panels.

Type RNGCAD <enter> to read the current RNGCAD settings. Below are the default values for each setting when the USARING OKAY or EURORING OKAY command is used.

USARING

RNGCAD 1 600 6000 750 7500
RNGCAD 2 0 0 0 0

EURORING*

RNGCAD 1 350 600 50 250*
RNGCAD 2 350 600 1850 2150*

* These settings match the Ireland telephone standard.

The Ring Cadence is the combination of ring signals and pauses that make up a valid telephone ring. Up to 2 rings and 2 pauses can be accepted with this command.

RNGCAD 1 allows you to set the time of the first ring and pause sequence.
RNGCAD 2 allows you to set the time of the second ring and pause sequence.

The ring and pause times are entered in milliseconds ranging from 0 to 9999. The first two numbers indicate the *minimum ring* and *maximum ring* times. The next two numbers indicate the *minimum pause* and *maximum pause* time.

For example, the default ring and pause settings of EURORING are defined as follow:

RNGCAD 1

350 = minimum ring (in milliseconds) 600 = maximum ring (in milliseconds)
50 = minimum pause (in milliseconds) 250 = maximum pause (in milliseconds)

RNGCAD 2

350 = minimum ring (in milliseconds) 600 = maximum ring (in milliseconds)
1850 = minimum pause (in milliseconds) 2150 = maximum pause (in milliseconds)

The default ring and pause settings of USARING are defined as follow:

RNGCAD 1

600 = minimum ring (in milliseconds) 6000 = maximum ring (in milliseconds)
750 = minimum pause (in milliseconds) 7500 = maximum pause (in milliseconds)

RNGCAD 2

All settings are set to 0 since the United States uses only one ring and one pause.

NOTE:

The CS-4000 does not answer a telephone line until it receives one complete ring. If the RNGCAD 1 and RNGCAD 2 settings are the same, the CS-4000 will not answer until after the second complete ring.

Other Changes

BUDDY ALARM REPORTS IN ITICOMP REPORTING FORMAT

On a buddy alarm the CS-4000 now generates a proper alarm code field of I CA when that channel is set to the ITICOMP format. Earlier software versions did not generate this code field.

NOTE:

Certain reports received by a the central station do not generate a I C field.

NON-ITI REPORTING FORMATS

The CS-4000 now displays reports in non-ITI formats (3/1, 4/2 etc.) one by one as they are received. Earlier software versions waited until all reports were received from a panel and then displayed them in a single batch.

PLEVEL COMMAND CHANGE:

If a PLEVEL 0 or PLEVEL 1 command is issued to CPU that is in alarm condition, the CPU's sirens will be turned off immediately.

ADEMCO/CAPS REPORTING FORMAT CHANGE

The CS-4000 ADEMCO/CAPS output format reports the zone as a 3 digit number, for example: 083 (phone test)

This format has always used the following "pseudo zones" to report special conditions:

018 exit fault
028 supervisory
038 low battery

IMPORTANT:

The above numbers are valid zone numbers on the Caretaker Plus! The above "pseudo zones" still hold true for other security panels. The Caretaker Plus and Meter Minder are the only panels to report special conditions as follows:

218 exit fault
228 supervisory
238 low battery

With unmodified ADEMCO/CAPS automation software, a Caretaker Plus zone 28 intrusion report will look a routine supervisory! A Caretaker Plus low battery report will look like an intrusion on zone 238!

GENERIC REPORTING FORMAT CHANGE

87 "Auto Forced Armed" alarm reports now set byte 13 (the alarm condition byte) to "S" instead of "A" in GENERIC format. 87 "Forced Armed" report still sets byte 13 to "A".

NON-INTERACTIVE COMMAND EXTENSION

CHANNEL *n* FORMAT BACKUP *primary*: Where *n* and *primary* are RS-232 output channels numbers 1 to 3.

The BACKUP Format is a new FORMAT that is designed as a way to redirect data on a failed output to a BACKUP printer. The BACKUP format is applied to channel *n*. The BACKUP format looks just like the EPSON format and is designed to be used with a printer. The difference between BACKUP and EPSON is that a BACKUP channel will be left turned OFF. It will turn itself ON if channel *primary* has a communication failure. In this way information will not be lost if the *primary* RS-232 output channel (usually an automation package) fails. Once ON it can be manually turned OFF when *primary* channel's failure is corrected. This "resets the trap," and the channel is once again ready to turn ON if there is a communication failure on the *primary* channel.

A communication failure is defined as one or more of the following ERROR messages:

- DSR Timeout!
- ACK Timeout!
- 20 NAKs

Any channel with BACKUP format will be permanently idle unless a channel *primary* is turned ON with the "proto =" option, the "DSR req =" option, or both turned ON.

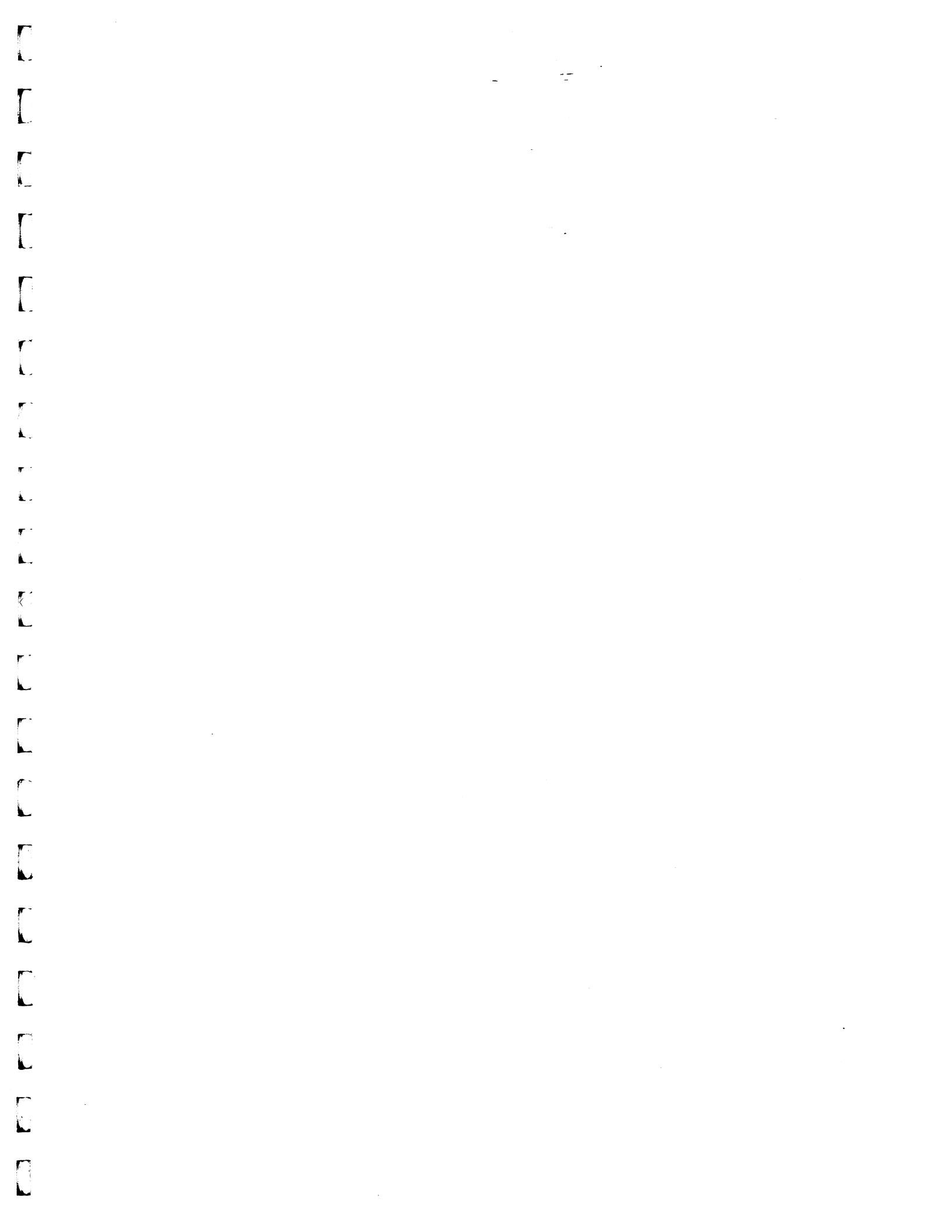



Interactive Technologies, Inc.
2266 North Second Street
North St. Paul, MN 55109

© 1990 Interactive Technologies, Inc.

46-056

