

24VAC or Battery Powered Z-Wave Thermostat Installation/User Guide

Content

Description	1
Battery Powered Operation	1
Installation Steps	2
Remove old thermostat	2
Heat Pump HVAC Systems Wiring	3
Mount the thermostat	3
Standard Gas/Electric HVAC System Wiring	5
Heat Pump HVAC System Wiring	6
Thermostat Setup: Configure for HVAC System	7
Changing the HVAC System Setup	7
Menu Options	7
Advanced System Settings Menu	8
Advanced Settings	8
Operation	10
Backlight and Button Operation	10
Thermostat Backlight Display	10
Setpoint Change	11
Fan Modes	11
Thermostat Menu Mode	12
Menu Mode Options	12
Thermostat Operation	13
Minimum Run Time (MRT)	13
Minimum off Time (MOT)	13
Z-Wave® Operation	13
FCC Compliance	14

Contact Information

For contact information, see www.utcfireandsecurity.com or www.interlogix.com.

For technical support, toll-free: 888.437.3287 / 855.286.8889 in the US including Alaska, Hawaii, Puerto Rico, and Canada.

Outside toll-free area, contact your dealer.

© 2019 UTC Fire & Security Americas Corporation, Inc.

Interlogix is part of UTC Climate Controls & Security, a unit of United Technologies Corporation.

All rights reserved.

Safety Information

WARNING: CHOKING HAZARD. The product accessory bag contains items that could be choking hazards. Please  keep away from small children.

AVERTISSEMENT: Le sachet de produits accessoires contient des éléments qui pourrait présenter un danger d'étouffement. Veuillez garder hors de la portée des jeunes enfants.

Description

This thermostat is compatible with most HVAC systems, including the following:

- 24VAC systems

Note: Requires both the 24VAC R and C (“common”) wires unless battery powered.

- Standard gas/oil/electric heating systems
 - ❖ 1 stage heating and cooling
 - ❖ 2 stage heating and cooling
- Heat Pump systems:
 - ❖ 1 stage heating and cooling
 - ❖ 2 stage heating and cooling
 - ❖ 2nd or 3rd stage Auxiliary heating (heat strips)

Warning! Do **NOT** use for line voltage controls (120/240VAC)

The thermostat can either be powered by batteries or 24VAC.

Battery Powered Operation

The thermostat can be powered by four AA Alkaline batteries. The thermostat will operate for approximately two years on four AA Alkaline batteries depending on the frequency of user operations and backlight operation. Always use alkaline batteries and replace all four at the same time with **NEW** batteries.

Z-Wave Operation when Battery Powered

IMPORTANT: If the thermostat is installed on a Z-Wave network, **while it is battery powered**, it does not work as a Z-Wave repeater.

24VAC Powered Operation

Powering the thermostat with 24VAC power **requires** both the C wire (24VAC common wire - typically blue) and the R wire (24VAC hot wire - typically Red). If the C wire is not available, then batteries are required.

Note: If the thermostat is powered from 24VAC, do not install batteries!

Z-Wave Operation when 24VAC powered

If the thermostat is installed on a Z-Wave network **while it is 24VAC powered**, it operates as an always-on Z-Wave repeater.

Installation Steps

1. Remove old thermostat
2. Install TBZ500 IS-ZW-TSTAT-500 (W for whit, B for black)
3. Set up the thermostat for the HVAC system
4. Enroll on Z-Wave network

Remove old thermostat

1. **Turn off power to the HVAC system.** Usually at the HVAC system or the circuit breaker panel.
2. Remove cover of old thermostat to expose the wiring terminals.
 - Take a picture of the wiring terminals! This will help with troubleshooting later if needed.
 - Mark the wires attached to the terminals with the wiring labels included.
3. Use the terminal labels and not the wiring color to mark the wires.
4. Remove the old thermostat base.

CAUTION: Don't let the wires slip into the wall.

Figure 1: Thermostat Wiring

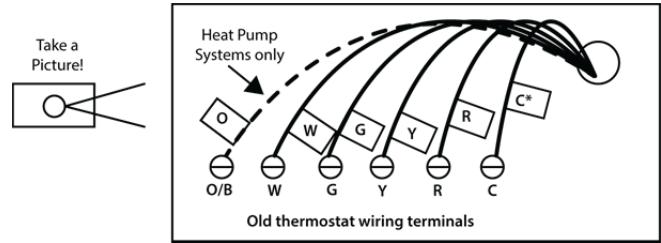

Note*: The C wire (24V common) may not be present.

If C wire is not present, the thermostat must be powered by batteries.

ATTENTION: If the C wire is present, you can power, **DO NOT INSTALL BATTERIES!**

Note: Mark the wires according to the terminal markings. There may be additional wires such as Y2, W2. If you have RC and/or RH connections, see below. Other wires are not used:

- **Wiring colors:** While the wiring terminals markings are intended to match the wire color (**R=Red, G=Green, W=White, Y=Yellow, O=Orange**), not all installations were correctly installed this way. Be sure to follow the terminal marking when marking the wires, even if the wire color doesn't match.
- **24VAC Power:** The thermostat requires the 24VAC C (common) wire be connected to operate without batteries. Otherwise 4 x AA batteries are required. Note that the 24VAC C common wire (usually Blue) may be present but not connect to 24VAC common at the HVAC system end. Be sure to check for 24V across R and C terminals if the thermostat does not power up without batteries. If there is no C "common" wire, batteries are required.

Connecting Wires (most common connections)

Mount the thermostat base to the wall using the wall anchors and screws provided; level as needed. Connect the wires according to the HVAC system type as below.

Standard Gas/Electric HVAC System Wiring

Figure 2: Single stage heating and cooling

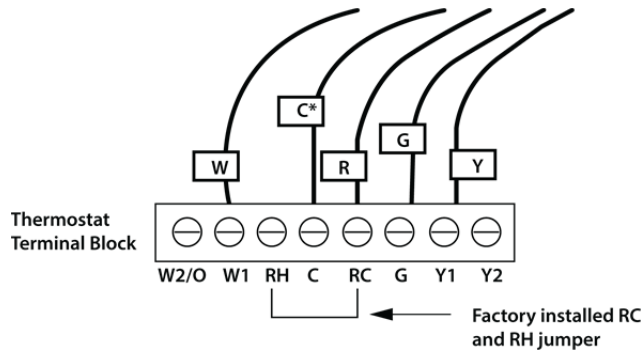

Note: Connect the wires as marked from the HVAC system to the corresponding terminals on the thermostat back.

*C wire (24VAC common) may not be present. If not, batteries must be installed.

R vs RC and RH Connections

- **Single Transformer HVAC Systems:** Typical modern central HVAC installations have an integrated heating and cooling system with a single 24VAC transformer. For these systems, there is only one 24VAC “R” wire and it can connect to either the RC or RH terminal on the thermostat. The thermostat is supplied with an RC-RH jumper installed. **Do not remove the jumper for common transformer HVAC systems.**
- **Separate Transformer HVAC Systems:** Some installations may have separate heating and cooling systems with separate 24VAC transformers. For those systems there will be a separate “R” wire for the heating system (RH) and cooling system transformers (RC).

To connect separate transformer systems, **FIRST REMOVE THE SUPPLIED RH-RC JUMPER.** Then connect the heating “R” wire to the RH terminal and the cooling “R” wire to the RC terminal on the thermostat.

Heat Pump HVAC Systems Wiring

Figure 3: Single stage heating and cooling

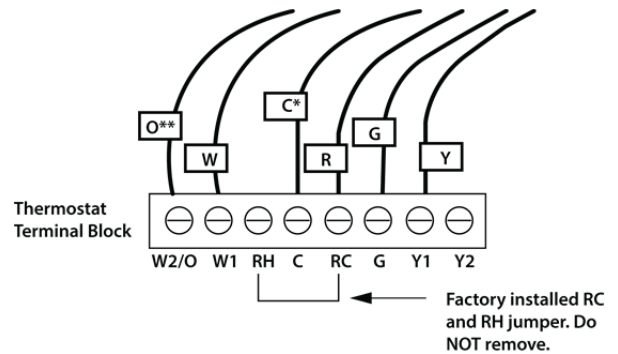

Notes: Connect the wires as marked from the HVAC system to the corresponding terminals on the thermostat back.

*C wire (24VAC common)

Heat Pump systems usually have the C wire connected to the thermostat. If there isn't a C wire, batteries must be installed.

** O (Orange) or B (Brown) wire (changeover valve) connect to the W2/O terminal on the thermostat.

Be sure to set the correct changeover operation (O = changeover with Cool, B = changeover with Heat) in the SETUP menu.

Connect the R wire to either RC or RH terminal.

Finish Wiring

- If you have additional wires for 2 stage systems (W2, Y2), see the wiring diagrams on page 5 and 6.
- Check that the wires are screwed into the terminal blocks firmly.
- Gently pull on the wires to confirm the connection.
- Push all the excess wiring back into the wall.

Mount the thermostat

- **24VAC Powered Thermostat:** If the thermostat is 24VAC powered (24VAC common “C” wire is connected), **DO NOT INSTALL BATTERIES!**

Figure 4: 24VAC Powered Thermostat

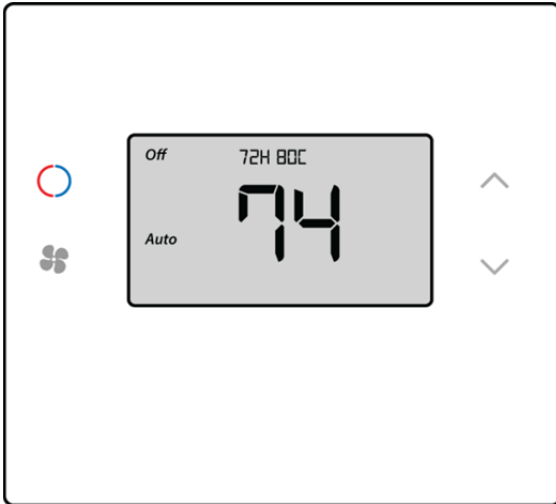

1. Install the thermostat on to the base.
2. Turn on power to the HVAC system/thermostat.

- **Battery Powered Thermostat:** If the thermostat is battery powered (NO 24VAC common “C” wire connected), install 4 NEW Alkaline AA batteries into the back of the thermostat.

Figure 5: Battery Powered Thermostat

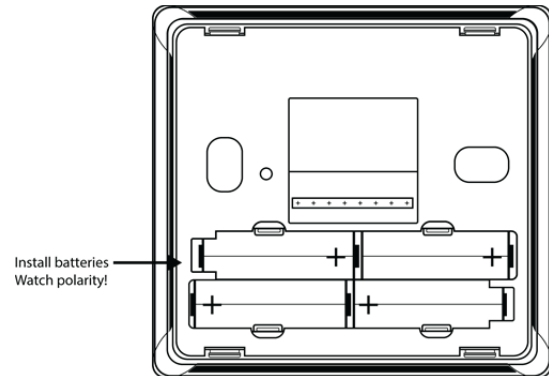

1. Install the thermostat on to the base.
2. Turn on power to the HVAC system/thermostat.

Standard Gas/Electric HVAC System Wiring

Figure 6: Thermostat wiring connection with standard HVAC system

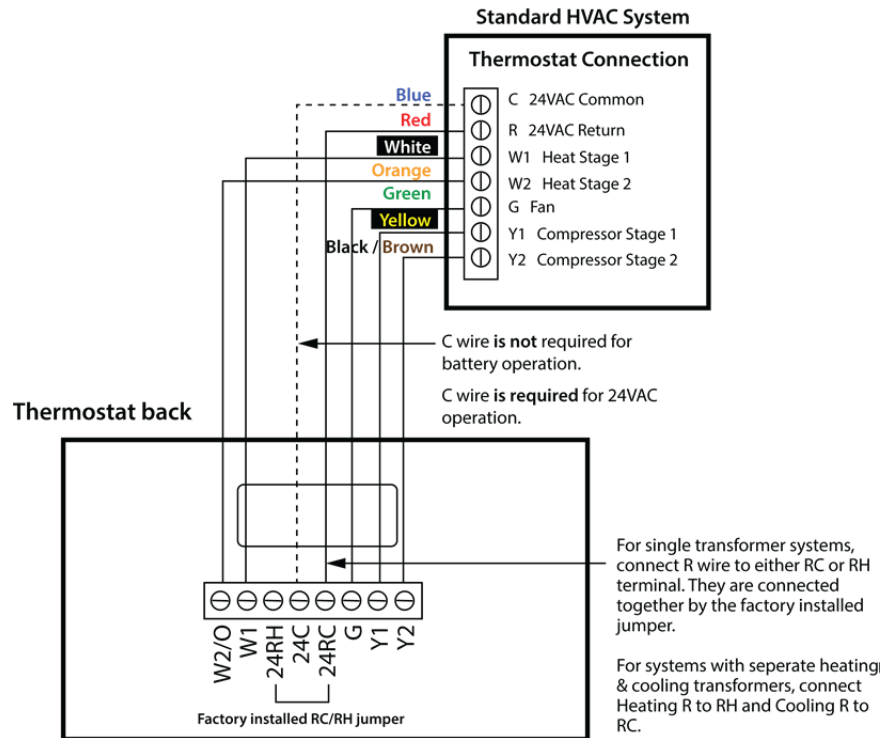

Note: Remove the factory installed RC/RH jumper.

Thermostat Setup: Standard Gas/Electric HVAC Systems

For Single Stage Heat/Cool Systems:

Go to the Menu screen by pressing and holding the FAN button  for 5 seconds.

Press the down arrow  to select the SYSTEM menu and press Select.

CAUTION: Typical thermostat wiring colors, verify that original wiring matches. Colors may be different.

Set the following:

System Type



- Set to **STANDARD**

Fan Type

- Set to **GAS** for typical gas furnace (fan is controlled by the furnace)
- Set to **ELECTRIC** for electric heat (fan on with heat call).

For Two Stage Heat/Cool Systems:

Go to **ADVANCED SYSTEMS SETTINGS** menu.

From the Setup menu screen, press and hold the Fan button  and Down arrow  buttons for 5 seconds. Use the Down arrow  button to select the following:

- **2nd Stage Heat Enable:** Enable second stage heating output.
 - ❖ If a single stage heating system, leave this set to N.
 - ❖ If a 2 stage heating system, set to Y to enable.
- **2nd Stage Cool Enable:** Enable second stage cooling output.
 - ❖ If a single stage cooling system, leave this set to N.
 - ❖ If a two stage cooling system, set to Y to enable.

Default Thermostat Setup:

- **Type:** Standard HVAC
- **Fan Type:** Gas Heat
 - ❖ 1 Stage heating
 - ❖ 1 Stage cooling

Note: No Setup change required for this configuration.

Heat Pump HVAC System Wiring

Figure 7: Thermostat Wiring connection with heat pump HVAC system

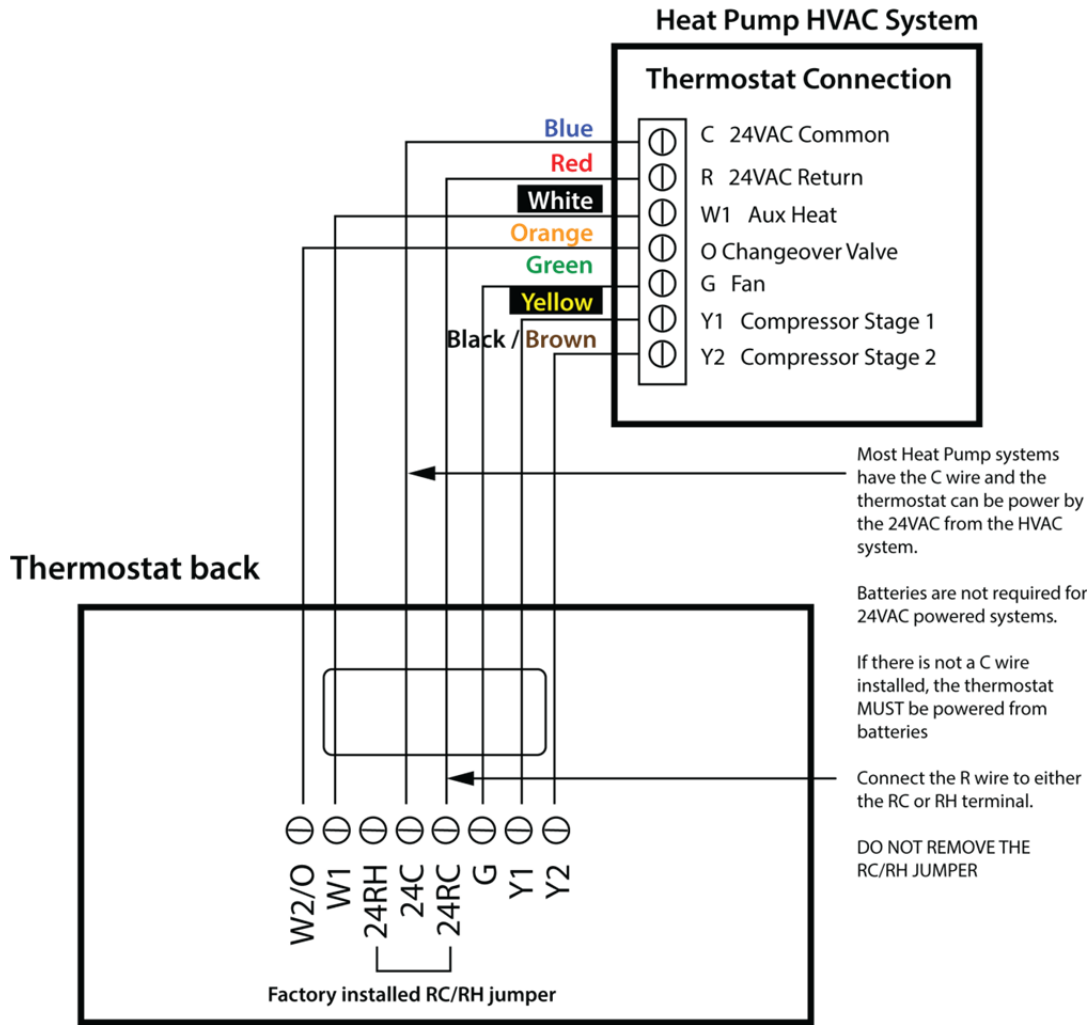



CAUTION: Typical thermostat wiring colors, verify that original wiring matches. Colors may be different.

Note: If you get heating when you expected cooling or vice versa, change the Change Over type to the opposite setting.

Thermostat Setup: Heat Pump HVAC Systems

For Single Stage Heat/Cool Systems:

1. Go to the Menu screen by pressing and holding the FAN button  for 5 seconds.
2. Press the down arrow  to select the SYSTEM menu and press Select.

Set the following:

- **System Type:** Set to **HEAT PUMP**
- **Change Over:** For changeover with cooling systems (Orange wire): set to **WITH COOL** (most common and default setting).



For changeover with heating systems (**Brown** wire): set to **WITH HEAT**.

You must configure the thermostat's changeover valve setting to work correctly with your HVAC system.

Check your system information to be sure and note the color of original thermostat wire and the terminal it was connected to.

No matter what the old stat connection was (O or B), connect the wire to the thermostats W2/O terminal.

For Two Stage Heat/Cool Systems:

Go to Advanced Systems Settings menu. From the Setup menu screen, press and hold the Fan  and Down arrow  buttons for 5 seconds. Use the Down arrow  button to select the following:

- **AUXHEAT:** If you have auxiliary heat strips, set this to Y to enable. (Default is Y).
- **2nd Stage Heat Enable:** Enable second stage heating outputs.
 - ❖ If a single stage heating system, leave this set to N
 - ❖ If a 2 stage heating system, set to Y to enable.
- **2nd Stage Cool Enable:** Enable second stage cooling outputs.
 - ❖ If a single stage cooling system, leave this set to N.
 - ❖ If a two stage cooling system, set to Y to enable.

Thermostat Setup: Configure for HVAC System

The thermostat must be set up for the correct HVAC system type and configuration for proper operation.

Preset HVAC System settings

The thermostat is preset for the following typical HVAC system configuration:

- HVAC system type: Standard gas/electric
- HVAC fan type: Gas heat
- HVAC heating stages: one
- HVAC cooling stages: one

If the thermostat is installed on this type HVAC system, the System setup does not need to be changed.

Installation is complete.

For thermostats installed on a Heat Pump HVAC system or any HVAC configuration other than the preset settings, the System settings need to be changed in the SYSTEM setup menu to match the HVAC system.

Changing the HVAC System Setup

To change the thermostats HVAC system settings, first select the Menu Screen and then select the **SYSTEM** menu. Follow instructions below to access the **SYSTEM** menu.

Note: To conserve battery life, the thermostat backlight turns off after a short time of no activity. The first press of any button will turn on the backlight but will not initiate any action other than turning on the backlight. Press the button again to initiate the action desired. If the backlight is already on, button presses work with the first press.

Go to Menu Screen



From the Thermostat Main Screen, press and hold the FAN button  until the Menu screen is displayed.

Figure 8: Main Screen

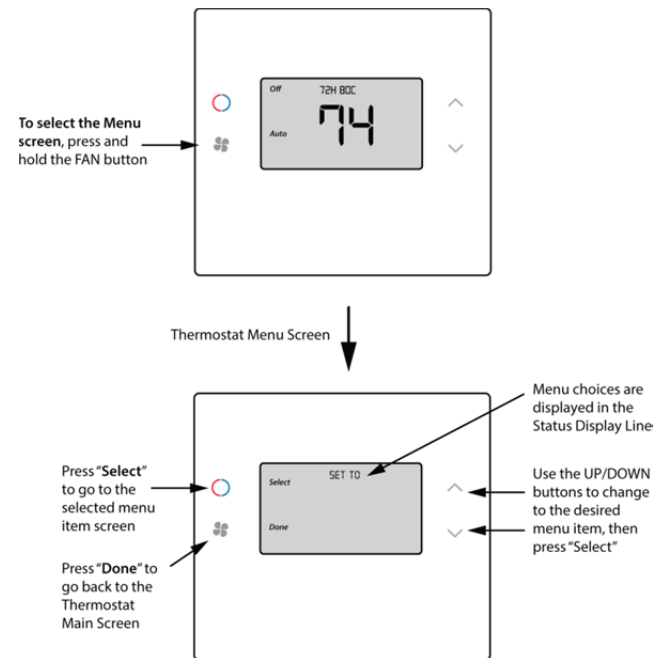

Menu Options

When the thermostat Menu Screen is displayed, use the Up  or Down  arrow buttons to scroll through the following options:

- **SETUP** (user preference settings)
- **SYSTEM** (HVAC system setup)
- **ZWAVE** (install/uninstall from Z-Wave network)
- **HUMIDITY**
- **INFO** (firmware versions and Z-Wave network information)

Select System setup

To change the HVAC system default settings, scroll down to the SYSTEM menu item and press “Select”.

System Setup Menu

The SYSTEM menu is used to set up the thermostat for the correct HVAC system type.

System Type

- For Standard Gas/Electric systems, select “Standard”. This is the default setting.
- For Heat Pump systems, use the Up/Down arrows to change to “Heat Pump”
- Press **Select** to set.
- Press **Done** to exit

Fan Type (For Standard HVAC systems only)

- Fan type depends on the heating system type.
- For Gas heat: select “GAS”. This is the default setting.
- For Electric heat: use the Up/Down arrows to change to “ELECTRIC”.
- Press **Select** to set
- Press **Done** to exit

Changeover Type (for heat pump HVAC systems only)

The changeover (or reversing) valve is used to change from heating to cooling operation. It is either a changeover with cooling type (**Orange** wire) or changeover with heating type (**Brown** wire). Most are changeover with cooling, which is the default setting.

- For Changeover with Cooling systems (**Orange** wire), select “WITH COOL”. This is the default setting.
- For Changeover with Heating systems (**Brown** wire), use the Up/Down arrows to change to “WITH HEAT”.
- Press **Select** to set
- Press **Done** to exit

Not sure which Changeover type?

Check the existing thermostat connections to help determine this.

- If the original system had an orange wire connected to the “O” terminal, then this is a “changeover with cool” system.
- If there was a **Brown** wire connected to the “B” terminal, then this is a “change over with heat” system.
- Set the Change Over setting accordingly.





CAUTION: These are typical wiring colors/connections and may differ.

- **If heating comes on when cooling is expected or vice versa, change the “Change Over Type” to the opposite setting.**

Advanced System Settings Menu

The Advanced System Settings Menu provides for addition system setup options. These settings can affect system operation and should only be changed by qualified HVAC installers.

To access the Advanced System Settings menu, first press and hold the Fan button  to get to the MENU screen.

Continue to hold down the Fan button  and press and hold the Down arrow button  for 5 seconds. The first menu item in the Advance System Settings menu “Display Lock” will be displayed. Use the Up/Down arrow buttons to scroll through the menu options to the desired setting. Press “Select” (Mode) button  to change a setting. Once it begins to flash, use the Up/Down buttons to select the desired setting. Press the “Select” button  to accept the new setting (flashing will stop).

Advanced Settings

Table 1: Advance Settings

Display Lock	Range: Y or N	Default: N
<ul style="list-style-type: none">• Y = Display LOCKED• N = Display UNLOCKED		
Allows the thermostat buttons to be locked. When the buttons are locked, none of the thermostat buttons will function as normal.		
To unlock the thermostat, press and hold the FAN button  for 5 seconds to access the Setup screen (it's the only button that works in the lock mode). Access the Advanced Settings Menu (as above) to turn the Display Lock off.		
Test Mode	Range Y or N	Default: N
Test mode shortens the system built-in delays (like MOT and MRT)		
<ul style="list-style-type: none">• Y= Test mode on. Reduces all delays to 10 sec for quicker system testing• N= Test mode off. Normal system delays		
Test mode will time out after 30 min and return to normal operation.		

Table 1: Advance Settings continued

Aux Heat Enable*	Range: Y or N	Default: Y
Enables the Auxiliary Heat operation. Typically, the Aux Heat will be heat-strips in a Heat Pump system Aux heat control is wired to the W1 terminal. Note*: Heat pump systems only.		
2nd Stage Heat Enable	Range: Y or N	Default: N
Enables the 2 nd Stage Heat operation		
2nd Stage Cool Enable	Range: Y or N	Default: N
Enables the 2 nd Stage Cool operation		
Minimum Run Time	Range: 1- 9 Minutes	Default: 3
Sets the Minimum Run Time (MRT) delay before a heating/cooling cycle can turn off. Sets heating/cooling cycle time. Prevents rapid on/off cycling.		
Minimum Off Time	Range: 5-9 Minutes	Default: 5
Sets the Minimum Off Time (MOT) delay before another heating/cooling cycle can begin. Provides compressor short cycle protection. "WAIT" is displayed on screen when active.		
Heat Setpoint Max	Range: 30°F to 109°F (0°C-43°C)	Default: 90°F (32°C)
Sets the maximum heating setpoint value. Will not ramp or accept setpoints higher than this maximum.		
Cool Setpoint Min	Range: 33°F to 112°F (2°C-45°C)	Default: 60°F (15°C)
Sets the minimum cooling setpoint value. Will not ramp or accept setpoints lower than this minimum.		
Heat Blower Off Delay	Range: 0-90 seconds	Default: 0 (off)
Sets the system blower delay off time after a heat call ends (fan purge).		
Cool Blower Off Delay	Range: 0-90 seconds	Default: 0 (off)
Sets the system blower delay off time after a cool call ends (fan purge).		
Heat - Cool Delta	Range: 3° - 15°	Default: 3°F (1°C)
Sets the minimum separation between heating and cooling setpoints.		

Table 1: Advance Settings continued

Setpoint Push		
<ul style="list-style-type: none"> Attempts to lower the cooling setpoint below the heating setpoint will PUSH the heating setpoint down to maintain the heat/cool delta separation. Attempts to set the heating setpoint above the cooling setpoint will PUSH the cooling setpoint up to maintain the setpoint heat/cool delta separation. 		
Heating Stage 1 On Threshold	Range: 1° to 6°	Default: 1°
Sets the delta from setpoint that stage 1 heating starts.		
Heating Stage 1 Off Threshold	Range: 0° to 5°	Default: 0°
Sets the delta from setpoint that stage 1 heating stops. Stage 1 turns off at setpoint + Delta Stage 1.		
Heating Stage 2 On Threshold	Range: 2° to 7°	Default: 2
Sets the delta from setpoint that stage 2 heating starts.		
Heating Stage 2 Off Threshold	Range: 0° to 6°	Default: 0°
Sets the delta from setpoint that stage 2 heating stops. Stage 2 turns off at setpoint + Delta Stage 2.		
Aux Heat On Threshold	Range: 3° to 8°	Default: 3°
Sets the delta from setpoint that stage 3 heating starts.		
Aux Heat Off Threshold	Range: 0° to 7°	Default: 0°
Sets the delta from setpoint that stage 3 heating stops. Stage 3 turns off at setpoint + Delta Stage 3.		
Cooling Stage 1 On Threshold	Range: 1° to 7°	Default: 1°
Sets the delta from setpoint that stage 1 cooling starts.		
Cooling Stage 1 Off Threshold	Range: 0° to 6°	Default: 0°
Sets the delta from setpoint that stage 1 cooling stops. Stage 1 turns off at setpoint - Delta Stage 1		
Cooling Stage 2 On Threshold	Range: 2° to 8°	Default: 2°
Sets the delta from setpoint that stage 2 cooling starts.		
Cooling Stage 2 Off Threshold	Range: 0° to 7°	Default: 0°
Sets the delta from setpoint that stage 2 cooling stops. Stage 2 turns off at setpoint - Delta Stage 2.		
Restore Defaults	Range: Yes, No	Default: No
Restores all settings to factory defaults. Press Yes to restore defaults Press No to exit and not restore defaults		

Operation

Backlight and Button Operation

The thermostat backlight is normally set to go out after 20 seconds of no button presses to conserve battery power. **If the backlight is off, the first button press of any button will only turn on the backlight, see Figure 1 (items 5-8).** Once the backlight is on, the buttons function normally.

Figure 9: Main Thermostat Screen

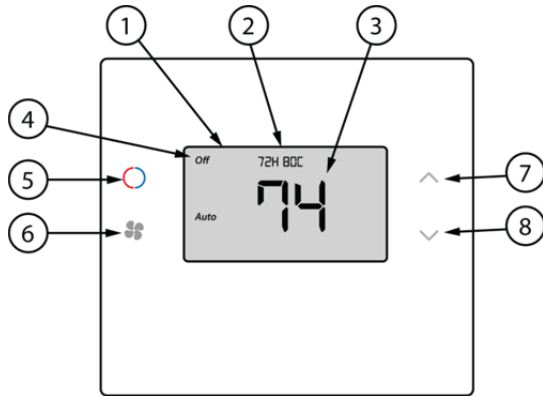

Figure 1 Legend:

- 1) Backlit Display
- 2) Text Display Line
- 3) Room Temperature
- 4) Button Mode Status Icon
- 5) Mode Touch Buttons
Heating/cooling Mode Selections
- 6) Fan Mode Icon
- 7) Temperature Setting Touch Button (Warmer)
- 8) Temperature Setting Touch Button (Cooler)

Thermostat Backlight Display

Figure 10: Thermostat Backlight Display (IS-ZW-TSTAT-500)

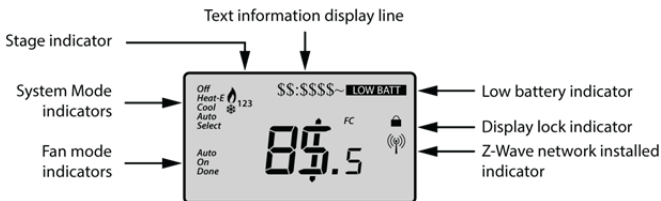

Table 2: System Operation Modes

Icon	Description
	System is ON and heating. If flashing, minimum run time (MRT) is active
	System is ON and cooling. If flashing, minimum run time (MRT) is active
LOW BATT	Battery indicator
	Display lock indicator
	Z-Wave network indicator

Stage Indicators

- “1” = Stage 1 heating or cooling is ON
- “2” = Stage 2 heating or cooling is ON
- “3” = Stage 3 heating (Aux Heat) is ON

For heat pump systems only:

- “Heat-E” = Emergency heat mode active

Figure 11: Setting the System Mode

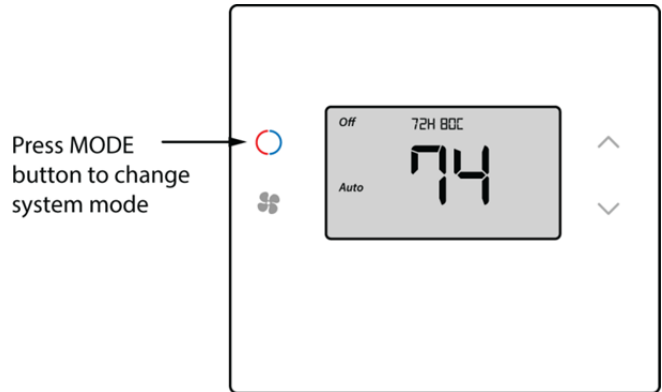

System Modes

- **Off:** System is off. No heating or cooling will come on. If system was on, it will turn off immediately.
- **Heat:** Only heating will occur.
- **Cool:** Only cooling will occur.
- **Auto:** Heating or cooling will come on according to the heating and cooling setpoints. The system will automatically switch between heating and cooling modes as needed to maintain the setpoints.

Special Heat Pump Mode: Emergency Heat

- Heat-E:** An additional system mode, “Heat-E” for Emergency Heat will be displayed if the HVAC System Type is set to Heat Pump. If there is a compressor failure with the Heat Pump system, setting the mode to Emergency Heat will allow the supplemental Aux Heat to come on first whenever there is a call for heating. It also disables the compressor output to prevent further damage to the HVAC system.

CAUTION! Emergency Heat should only be used for emergencies until the HVAC system can be repaired. *Running the system in Emergency Heat mode is commonly the most expensive mode since only the electric heat strips are being used instead of the more efficient heat pump compressor.*

Figure 12: Setting the Heating or Cooling Temperature Setpoint

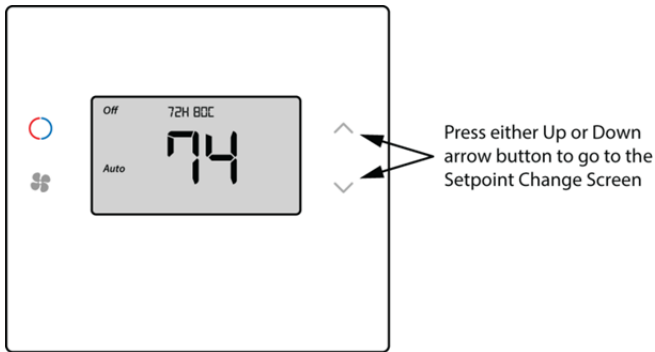

Setpoint Change

To change the setpoint, press the Up or Down arrow buttons. The screen will switch to the setpoint change screen (as above) and show the current setpoint of the current heating or cooling mode. Adjust setpoint temperature up or down with the arrow buttons.

Note: When in the Setpoint Change screen, pressing the **MODE** button will switch the setpoint being displayed between the Heat and Cool setpoints.

- Setpoint Push:** The cooling setpoint cannot be set below the heating setpoint. The thermostat will “push” the heating setpoint lower if the cooling setpoint is set below the current heating setpoint. A 3° separation is maintained between the heating and cooling setpoints. The same is true for raising the heating setpoint above the cooling setpoint. The thermostat will “push” the cooling setpoint up to maintain the 3° separation.

Figure 13: Setpoint Change Screen

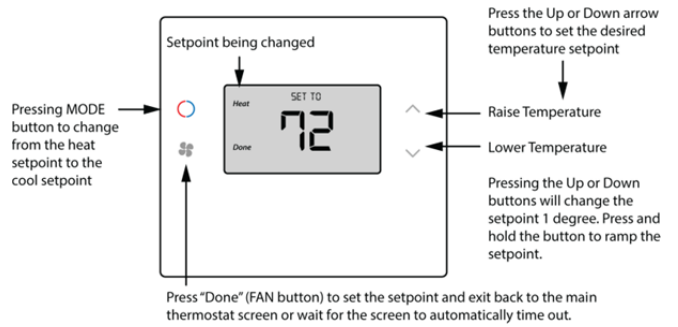

Fan Modes

- Auto:** Fan automatically operated by the HVAC system. (normal setting)
- On:** Manual Fan mode. Fan stays on until mode is changed back to Auto, independent of the heating or cooling system operation.

Figure 14: Setting the Fan Mode

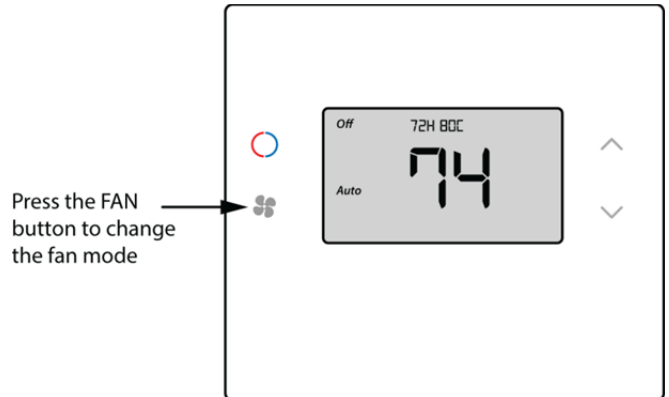

Thermostat Menu Mode

The Thermostat has a menu of setup and information displays. To change to the Menu Mode, press and hold the FAN button  for 5 seconds. The display will change to the Menu Mode and display the Setup screen. Use the Up/Down arrow buttons to scroll through other menu items.

Figure 15: Thermostat Main Screen



Menu Mode Options

- **SETUP:** User preference settings
- **SYSTEM:** Thermostat HVAC system settings
- **ZWAVE:** Z-Wave network install or remove
- **INFO:** Displays thermostat version and setup info

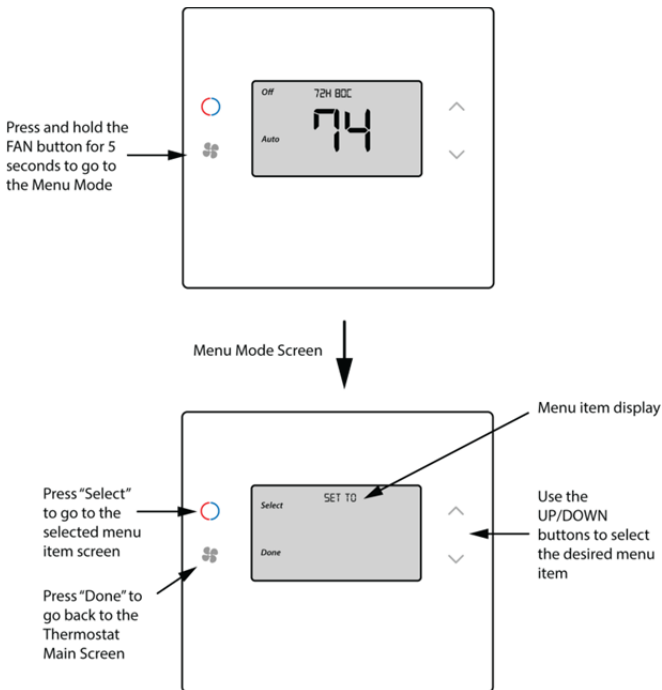
Setup Menu

User preference settings are as followed:

- **Fahrenheit or Celsius:** Select the temperature display mode.
- **Backlight Timeout:** Sets the time from last button press that the backlight will turn off; range: 10 - 30 seconds.

Note: Long backlight timeouts will reduce battery life.

If the thermostat is powered from 24VAC, the backlight timeout can be set to "0" which will keep the backlight on continuously.

- **Temperature Sensor Calibration:** Change the temperature calibration by $\pm 7^\circ$. Use the Up/Down arrow buttons to change to the desired temperature displayed.
- **Humidity Sensor Calibration:** Change the humidity calibration by $\pm 7\%$. Use the Up/Down arrow buttons to change to the desired humidity displayed.
- **Status Line display:** Select Setpoints or Humidity to be displayed on the upper status line.

System Menu

- **System type:** Select the system type, **Standard** or **Heat Pump**

Fan type (standard systems only)

- **Select fan type:**
 - ❖ **Gas** (typical default setting) or **Electric**

Change over type (heat pump systems only)

- **Select the Changeover type:**
 - ❖ Changeover WITH COOL (typical default setting)
 - ❖ Changeover WITH HEAT

See Installation Guide for more information on System setup and the Advanced Systems Menu.

Z-Wave Menu

This menu item allows the thermostat to be enrolled to the Z-Wave network. Follow the instructions shown in the Z-Wave Operation section (page 18) to enroll the Thermostat onto the network.

INFO Menu

The INFO menu displays information about the thermostat. Use the Up/Down buttons to scroll through the various items.

Thermostat information displayed:

- **Version:** Thermostat firmware version
- **ZWAVE:** Z-Wave firmware version
- **Node ID:** Z-Wave Node ID
- **Home ID:** Z-Wave Home ID
- **System type:** Displays current System Type settings (Standard or Heat Pump)

If System Type = Standard

- **Fan type:** Displays current Fan Type setting

If System type = Heat Pump

- **Changeover type:** Displays current Change Over valve (reversing valve) setting
- **AC or Battery Powered:** AC POWER will be displayed if power by 24VAC

Thermostat Operation

Minimum Run Time (MRT)

The thermostat has a Minimum Run Time (MRT) delay after the start of any heating or cooling call. This minimum run time assures even heating and cooling cycles. The MRT will keep the system on, even if it reaches the setpoint room temperature, or you change the setpoint to a temperature that would satisfy the call, until the MRT expires. Changing the Mode to OFF will cancel the MRT and the system will turn off immediately. The MRT can be adjusted in the Advanced Settings menu of the thermostat.

Note: When MRT is active, the heating or cooling icon will be flashing.

Minimum off Time (MOT)

The thermostat has a Minimum off Time (MOT) delay after any heating or cooling cycle ends. This delay prevents rapid heating/cooling cycles and also provides “short cycle protection” for the system compressor. This delay may be noticeable when you change a setpoint and it does not respond immediately due to the MOT delay timer preventing the system from restarting. The MOT delay time can be adjusted in the Advanced Settings menu of the thermostat but there is a minimum of a 5 minute delay to assure compressor protection.



Note: When MOT is active, the thermostat Status Display shows “WAIT”.

Z-Wave® Operation

- **Thermostat Battery Operation:** If the thermostat is installed in a Z-Wave network while powered by batteries, it will be enrolled as a Z-Wave FLiRs (frequently listening receiver slave) type device. This is a power saving mode that conserves the batteries by keeping the radio asleep most of the time. However, in this mode, the thermostat does not act as a repeater/router in the Z-Wave network.
- **Thermostat 24VAC Operation:** If the thermostat is installed in a Z-Wave network while powered by 24VAC, it will be enrolled as an always-listening device and can act as a router node in the Z-Wave network.

CAUTION! Once installed in a Z-Wave network, if you change how the thermostat is powered (from batteries to 24VAC or vice versa), you must remove and re-enroll the thermostat in the Z-Wave network for it to work correctly.

Adding the thermostat to a Z-Wave network

3. Follow the instructions provided with your system for enrolling the thermostat.
4. Press and hold the FAN button  on the Thermostat until the screen changes to the Menu screen.
5. Press the UP button until ZWAVE is shown in the Status Display line then press Select.
6. INSTALL should be shown on the status line.
7. When instructed by your system installation to add the thermostat to the network, press the “Select” button to install. Wait until SUCCESS or FAILED is shown on the status display.
8. Press Done on the Thermostat to exit the ZWAVE screen.
9. Press Done on the Thermostat again to exit the Menu screen.
10. Once enrolled on your system’s network, continue to follow the instructions provided to complete the enrollment and naming of the thermostat.
11. The  indicator should be shown on the Thermostat Main screen indicating the thermostat has successfully been enrolled into the Z-Wave network.

Removing the thermostat from a Z-Wave network

It may be necessary to remove and/or reinstall the thermostat from a Z-Wave network, if the thermostat has been previously installed on another network.

Follow the instructions supplied with your Z-Wave system to remove/uninstall a Z-Wave device. When the system instructs you to press and release the Z-Wave button on the thermostat, follow these steps:

1. Press and hold the FAN button  for 3 seconds until the Menu screen is displayed.
2. Press the UP arrow button to scroll to the “ZWAVE” menu.
3. Press “Select” to select the ZWAVE screen.
4. The display will show “REMOVE” in the text line.
5. Press “Select” to perform the remove action.
6. “WAIT” will be displayed in the text line. The remove operation is in process.
7. “SUCCESS” will be display when the reset is completed.
8. Press “Done” to exit back to the thermostat screen.
9. Thermostat is now ready to be added to the wireless network.

FCC Compliance

This device complies with Part 15 of the FCC Rules. Operation is subject to the following two conditions: (1) This device may not cause harmful interference, and (2) This device must accept any interference received, including interference that may cause undesired operation.

This equipment has been tested and found to comply with the limits for Class B Digital Device, pursuant to Part 15 of the FCC Rules. These limits are designed to provide reasonable protection against harmful interference in a residential installation. This equipment generates and can radiate radio frequency energy and, if not installed and used in accordance with the instructions, may cause harmful interference to radio communications. However, there is no guarantee that interference will not occur in a particular installation. If this equipment does cause harmful interference to radio or television reception, which can be determined by turning the equipment off and on, the user is encouraged to try to correct the interference by one or more of the following measures.

- Reorient or relocate the receiving antenna
- Increase the separation between the equipment and receiver
- Connect the equipment into an outlet on a circuit different from that to which the receiver is connected
- Consult the dealer or an experienced radio/TV technician for help

Any changes or modifications not expressly approved by the party responsible for compliance could void the user's authority to operate the equipment.

This device complies with Industry Canada license-exempt RSS standard(s). Operation is subject to the following two conditions: (1) this device may not cause interference, and (2) this device must accept any interference, including interference that may cause undesired operation of the device.

Le présent appareil est conforme aux CNR d'Industrie Canada applicables aux appareils radio exempts de licence. L'exploitation est autorisée aux deux conditions suivantes : (1) l'appareil ne doit pas produire de brouillage, et (2) l'utilisateur de l'appareil doit accepter tout brouillage radioélectrique subi, même si le brouillage est susceptible d'en compromettre le fonctionnement.