

SuperBus 2000 Voice Module Installation Instructions

Product summary

The SuperBus[®] 2000 Voice Module provides voice functions for Concord[™] (v2.0-later), Concord 4[™], Concord Express[™], and Concord Express[™] (v4) panels.

Using an onboard, digital voice chip, the panel announces status messages through each phone and speaker connected to the module. In addition, a vocabulary of more than 220 words provides easy to understand messages.

The voice module provides feedback for single or multiple-partition panels. For multiple partitions, a module can be used for each partition and connected to a separate speaker.

The module communicates with the panel through the SuperBus 2000[®] digital databus and may be powered by the panel's 12V DC supply or an auxiliary 12V DC power supply with backup battery.

Features

The Voice Module includes the following features:

- User-adjustable, speaker volume control.
- Extensive, 220-plus word vocabulary.

Figure 1: Voice module components and mounting holes

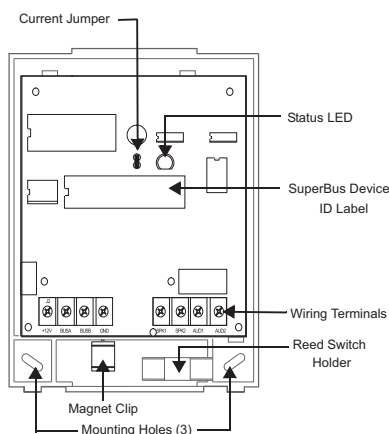

Table 1: Module component descriptions

Component	Function
Device ID Label	Identifies a unique device ID number.
Status LED	Flashes to indicate normal panel communication.
Wiring Terminals	Provides panel and speaker connections.
Current Jumper	Reduces current consumption to 300 mA.

Installation guidelines

- Use four-conductor, 22-gauge or larger diameter stranded wire to connect the module to the panel.
- Install the module inside the panel cabinet or as close to the cabinet as possible.
- For Concord Express systems, leave the current jumper installed; when installing a Concord (v2.0-later), Concord 4, or Concord Express (v4) panel, remove the current jumper.
- When the current jumper is installed, the voice module draws a maximum 300 mA from panel power supply. When the current jumper is removed, the module draws a maximum of 600 mA from panel power supply.
- When using panel power to supply bus or hardwired devices, *do not* exceed the panel's total power output. Refer to specific panel *Installation Instructions* for further detail.

Tools and Supplies Needed

- Slotted screwdriver
- 3/8"-drive drill and drill bits
- Wire cutter/stripper
- Screws and anchors (included)
- Four-conductor, 22-gauge or larger stranded wire
- Support standoff (included with Concord cabinets)
- 1/4" press-fit reed switch and magnet (not included)

Installation

The module can be mounted:

- On a wall.
- Inside a Concord, Concord 4, Concord Express, or Concord Express (v4) cabinet.
- Inside a Concord Expansion Enclosure. Refer to specific cabinet *Installation Instructions* for procedures

Caution: To prevent damage to the panel or module, remove the panel's AC power transformer and disconnect the backup battery before installation.

You must be free of static electricity when handling electronic components. Touch a bare metal surface before touching the circuit board.

Mounting the Module on a Wall

1. Remove the module cover (see Figure 2 below).

Figure 2: Removing the module cover

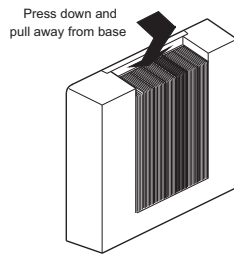

2. Place the backplate on the wall and mark the three mounting holes (see Figure 1 on page 1).
3. Drill for the mounting holes and insert appropriate anchors.
4. Secure the backplate to the wall with the included screws.

Mounting a Module in a Concord, Concord 4, or Concord Express (v4) Panel

1. Remove the panel's AC power transformer and disconnect the backup battery.
2. Remove and discard the module cover (see Figure 2 above).
3. Insert support standoffs on to the panel circuit board (see Figure 3 below).

Figure 3: Support standoff

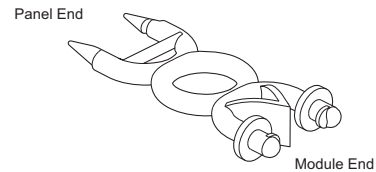

4. Slide the module backplate on to the clips located in the cabinet's center or top-left corner (see Figure 4 below).

Note: The mounting clips in the *top-right* corner of the cabinet are designed for a receiver module. If a receiver module is not in use, the mounting clips may be used for the voice module.

5. Push the lower-right corner of the module on to the support standoff (see Figure 4 below).

Figure 4: Mounting the module in a Concord, Concord 4, or Concord Express (v4) cabinet

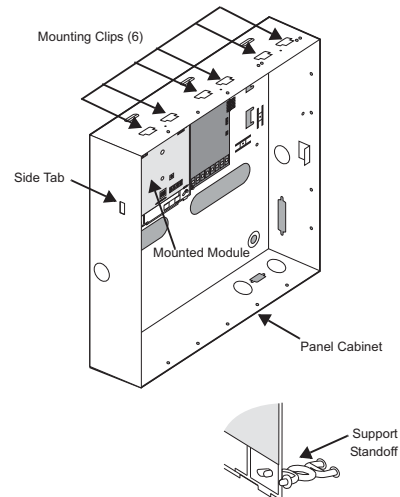

Mounting the Module in a Concord Express Panel

1. Remove the panel's AC power transformer and disconnect the backup battery.
2. Remove and discard the module cover (see Figure 2 above).
3. Position the module over the cabinet mounting holes so the terminals are to the left (see Figure 5 on page 3).
4. Secure the module to the cabinet with the mounting screws.

Figure 5: Mounting the module in a Concord Express cabinet

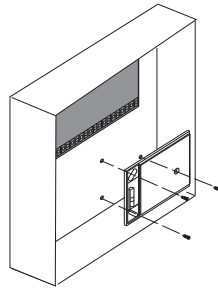

Wiring

Wiring the Voice Module includes the following:

- Running required wires for power, bus, and speaker communications.
- Connecting module wires for use in a Concord system.

For power and bus connections, route a four-conductor, 22-gauge or larger diameter stranded wire from the module to the panel (see Table 2 below for wire length limits). Route a two-conductor, 22-gauge or larger stranded wire cable from the module to the speaker.

Table 2: Maximum Bus and power wire lengths

Wire gauge	Maximum length
18	120 feet
22	40 feet

Table 3: Maximum speaker wire lengths

Wire gauge	Maximum length
18	440 feet
22	175 feet

Wiring Connections for Concord, Concord 4, and Concord Express (v4) Panels

Figure 6: Wiring module and speaker - Concord, Concord 4, or Concord Express (v4) panels

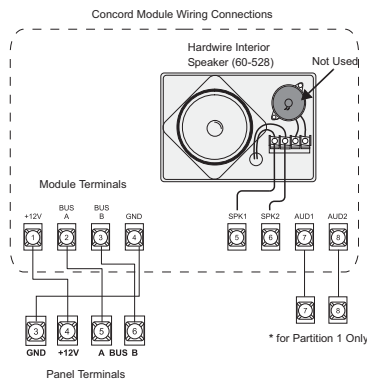

Wiring Connections for Concord Express Panels

Figure 7: Wiring module and speaker in a Concord Express panel

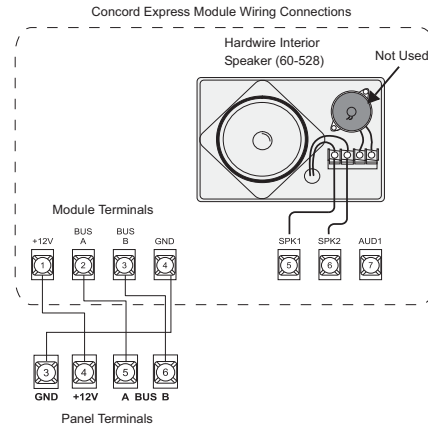

Installing a Cover Tamper Switch

If you do not mount the module inside a cabinet, it is recommended that you add a cover tamper switch.

To mount a tamper switch, first install a UL listed 1/4-inch press-fit reed switch on the module backplate. Next, wire the switch to any unused panel, module, or SnapCard™ zone input terminal.

Once programmed, if someone opens the module cover, the tamper switch opens and causes an alarm.

The reed switch holder and magnet clip are located on the bottom of the backplate (see Figure 1 on page 1).

1. On the module's backplate, place the reed switch into the reed switch holder.
2. Remove the magnet clip from the module backplate and insert the magnet into the tabs on the module cover. Next, press the magnet clip over the magnet until the clip locks into place (see Figure 8 on page 4).
3. Connect the normally closed reed switch (in series with a 2k Ohm EOL resistor) to any zone input and zone common terminal (see Figure 8 on page 4). The resistor should be located inside the module cover at the reed switch.

Figure 8: Installing the reed switch

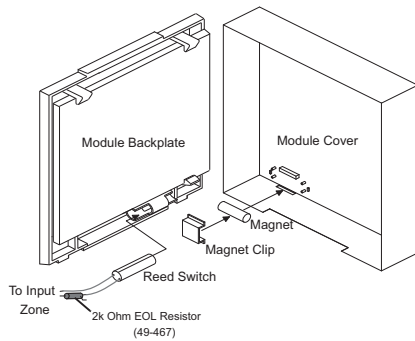

2. Inspect for proper wire connections.
3. Ensure the panel's AC power transformer is plugged in and the backup battery is connected.
4. If the status LED remains off, replace the module.

Specifications

Compatibility	Concord, Concord 4, Concord Express, and Concord Express (v4) panels.
Power requirements	12V DC nominal; 600 mA maximum; 300 mA with Jumper installed.
Operating temperature	32° to 120°F (0° to 49°C)
Storage temperature	30° to 140°F (-34° to 60°C)
Max. relative humidity	90%, non-condensing
Dimensions	5.25" x 4.125" x 1.0" (L x W x D)

Power Up and Bus Communication

For Concord, Concord 4, and Concord Express (v4) Panels

Note: To enter the panel's program mode and verify unit numbers, an alphanumeric touchpad must be connected to all Concord panels.

When powering the system and verifying bus communication, follow the procedures listed below.

1. Verify that panel, touchpad, and module wiring is correct.
2. Connect the panel's backup battery and plug in the AC power transformer. An alphanumeric touchpad display appears.
3. Verify the module's status LED flashes.
4. If desired, enter the panel's program mode to verify if a device ID exists (see panel specific panel *Installation Instructions* for further detail).

Note: If the status LED does not flash, unplug the panel's AC power transformer and disconnect the backup battery.

Replacing Module Cover/Closing Cabinet

- If the Voice Module is mounted on a wall, replace the cover.
- If the Voice Module is mounted in a cabinet, close the cabinet door.

Testing and Troubleshooting

If the module's status LED remains off:

1. Enter the panel's program mode to verify the panel recognizes the module (see specific panel *Installation Instructions*).

Regulatory information

Manufacturer	UTC Fire & Security Americas Corporation, Inc. 1275 Red Fox Rd., Arden Hills, MN 55112-6943, USA
UL listings	UL 985 Household Fire Warning System Units UL 1023 Household Burglar Alarm System Units

FCC compliance

FCC Part 15 Information to the User

Changes or modifications not expressly approved by UTC Fire & Security can void the user's authority to operate the equipment.

FCC Part 15 Class B

This equipment has been tested and found to comply with the limits for a Class B digital device, pursuant to Part 15 of the FCC Rules. These limits are designed to provide reasonable protection against interference in a residential installation.

This equipment generates, uses, and can radiate radio frequency energy, and, if not installed and used in accordance with the instructions, may cause harmful interference to radio communications. However, there is no guarantee that interference will not occur in a particular installation.

If this equipment does not cause harmful interference to radio or television reception (which can be determined by turning the equipment off and on), the user is encouraged to correct the interference by one or more of the following measures:

- Reorient or relocate the receiving antenna.
- Increase the separation between the equipment and receiver.
- Connect the affected equipment and the panel receiver to separate outlets on different branch circuits.
- Consult a dealer or experienced radio/TV technician for help

Contact information

www.utcfireandsecurity.com or www.interlogix.com

For customer support, see www.interlogix.com/customer-support

Copyright © 2011 UTC Fire & Security Company. All rights reserved.