

TVB-WBS Stainless Steel Bullet (Box Camera Housing) Wall Mount Installation Instructions

Specifications

Dimensions: 412.5 × 140 × 228 mm
(16.24 × 5.51 × 8.98 in.)

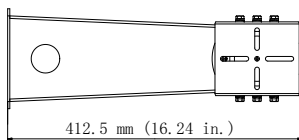
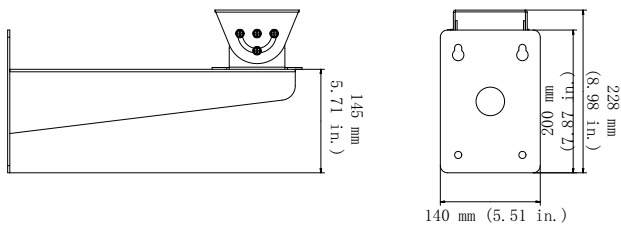

Weight: 3.80 kg (8.38 lb.)

Accessories:

Expansion anchors: 4 pcs

Used to install the TVB-WBS stainless steel wall mount to the mounting surface.

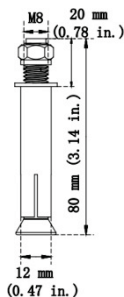

Screw A: 4 pcs

Used to install the stainless steel bullet camera to the TVB-WBS wall mount.

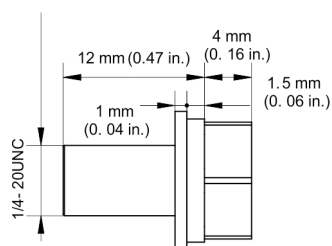

Supported cameras

The stainless steel wall mount can be used with following cameras:

Stainless Steel Bullet (Box Camera Housing) Camera:	TVB-5801, TVB-5802
---	--------------------

Installation

To install the stainless steel bullet (box camera housing) camera to the TVB-WBS:

1. Mark and drill the mounting holes for the expansion anchors in the mounting surface. Hammer the supplied M8 expansion anchors into the mounting holes.

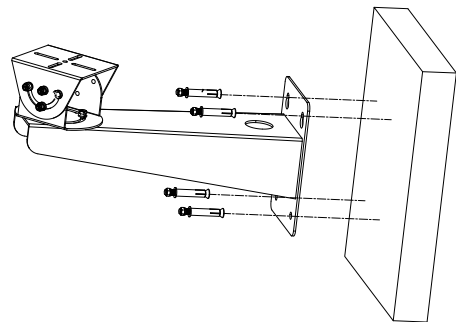

2. The wall mount allows you to adjust the position of the camera by using the pan (2) and tilt (1) adjust brackets. You may not need to use all the screws provided to lock the camera into position, depending on the amount of range required.

Note: If preferred mount the bullet (box camera housing) on the wall mount without removing the universal joint base (2). Use screw A as shown in step 5.

3. Remove the eight screws that attach the tilt bracket (1) to the pan bracket (2)

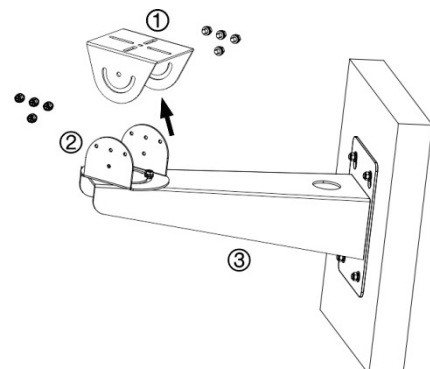

- Route the cable harness through the cable access hole in the wall mount.
- Secure the housing base (1) to the tilt bracket (2) using screw A (3), as shown below.

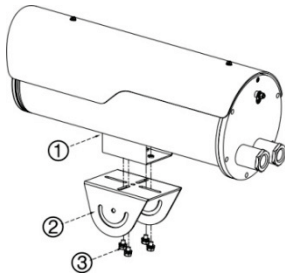

- Loosen the three pan adjustment screws (1) and rotate the camera housing to the proper location).

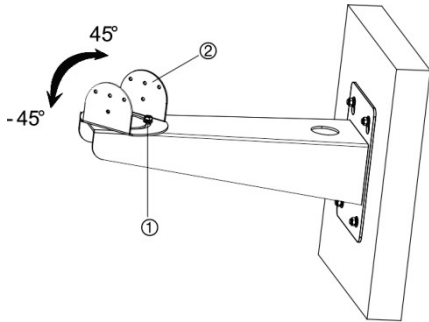

- Once the camera is pointing towards the targeted scene, tighten the pan adjustment screws. Install the camera housing on the wall mount by matching up the pan and tilt brackets, as shown. Use two of the screws to attach the brackets together, using the non-slotted screw holes. The other screws are used to set the tilt angle. Depending on the tilt angle required, all the screws may not be needed. Once the tilt angle is set, tighten the tilt adjustment screws to lock the position in place.

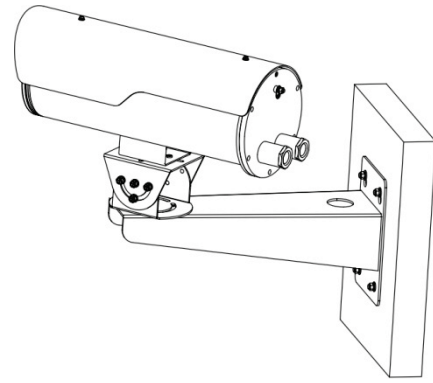
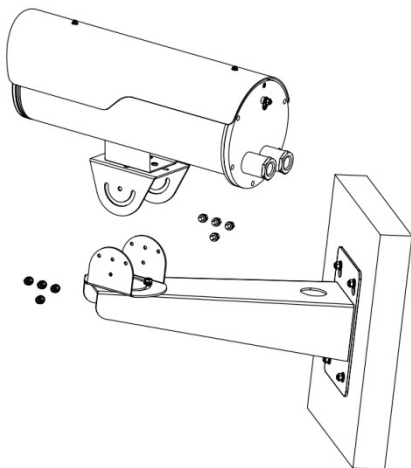

Legal and regulatory information

Trademarks and patents The trade names used in this document may be trademarks or registered trademarks of the manufacturers or vendors of the respective products.

Manufacturer Interlogix.
2955 Red Hill Avenue, Costa Mesa, CA 92626
5923, USA
Authorized EU manufacturing representative:
UTC Fire & Security B.V.
Kelvinstraat 7, 6003 DH Weert, The Netherlands

Certification



Product warnings and disclaimers

THESE PRODUCTS ARE INTENDED FOR SALE TO AND INSTALLATION BY QUALIFIED PROFESSIONALS. UTC FIRE & SECURITY CANNOT PROVIDE ANY ASSURANCE THAT ANY PERSON OR ENTITY BUYING ITS PRODUCTS, INCLUDING ANY "AUTHORIZED DEALER" OR "AUTHORIZED RESELLER", IS PROPERLY TRAINED OR EXPERIENCED TO CORRECTLY INSTALL FIRE AND SECURITY RELATED PRODUCTS.

For more information on warranty disclaimers and product safety information, please check www.firesecurityproducts.com/policy/product-warning/ or scan the following code:



Contact information and manuals

For contact information go to: www.interlogix.com or www.firesecurityproducts.com
To get translations for this and other product manuals go to: www.firesecurityproducts.com