





UltraView UVD-6130VE-2 WDR Dome Camera User Manual

Copyright	© 2012 UTC Fire & Security. All rights reserved.
Trademarks and patents	<p>The TruVision and Interlogix names and logo are trademarks of UTC Fire & Security.</p> <p>Other trade names used in this document may be trademarks or registered trademarks of the manufacturers or vendors of the respective products.</p>
Manufacturer	<p>UTC Fire & Security Americas Corporation, Inc. 2955 Red Hill Avenue, Costa Mesa, CA 92626-5923, USA</p> <p>Authorized EU manufacturing representative: UTC Fire & Security B.V. Kelvinstraat 7, 6003 DH Weert, The Netherlands</p>
Certification	  N4131
FCC compliance	<p>Class A: This equipment has been tested and found to comply with the limits for a Class A digital device, pursuant to part 15 of the FCC Rules. These limits are designed to provide reasonable protection against harmful interference when the equipment is operated in a commercial environment. This equipment generates, uses, and can radiate radio frequency energy and, if not installed and used in accordance with the instruction manual, may cause harmful interference to radio communications. Operation of this equipment in a residential area is likely to cause harmful interference in which case the user will be required to correct the interference at his own expense.</p>
ACMA compliance	<p>Notice! This is a Class A product. In a domestic environment this product may cause radio interference in which case the user may be required to take adequate measures.</p>
European Union directives	<p>12004/108/EC (EMC directive): Hereby, UTC Fire & Security declares that this device is in compliance or with the essential requirements and other relevant provisions of Directive 2004/108/EC</p> <p>2002/96/EC (WEEE directive): Products marked with this symbol cannot be disposed of as unsorted municipal waste in the European Union. For proper recycling, return this product to your local supplier upon the purchase of equivalent new equipment, or dispose of it at designated collection points. For more information see: www.recyclethis.info.</p>
Contact information	<p>For contact information, see www.utcfireandsecurity.com or www.utcfssecurityproducts.eu.</p>



Content

Product overview	2
Package Contents	2
Features	2
User guidelines	3
Product description	3
OSD control pad	3
Installation	5
Mount the camera	5
Connect the cables	5
Adjust the lens	5
Adjust the focus and zoom	6
Programming	7
Access the Setup menu	7
Select the lens type	8
Set shutter/AGC	8
Adjust the picture characteristics	10
Set white balance	10
Set WDR	11
Set image noise reduction	12
Set HLC and BLC	12
Set Day/Night mode	13
Set E-zoom	14
Set DIS	14
Set the privacy mask area	14
Set motion detection	15
Display the synchronization mode	15
Set the camera ID	16
Select the language	16
Reset camera settings	16
Save all changes	16
Specifications	17
Dimensions	17
Menu Map	18

Product overview

The UVD-6130VE-2 WDR camera uses a digital signal processor (DSP) to process video signals. The camera includes a microcontroller to provide high-quality images with high-color reproduction and sharp pictures.

Package Contents

The package contains the following:

- Dome camera
- Monitor output cable
- Mounting screws, wall anchors, and hex wrench
- Power terminal
- Ceiling drilling holes template
- Quick start guide

Note: Use the video output BNC and power jack for normal system operation. Use the monitor output cable for installation and maintenance.

Features

The camera includes the following features:

- Super HAD II (hole accumulated diode) technology with 480,000 pixels NTSC (570,000 PAL)
- Use of LSI (large scale integration) digital processors to produce 650 lines of horizontal resolution
- Smart digital control automatic BLC (backlight compensation)
- WDR (wide dynamic range)
- Advanced auto exposure system for both fixed iris and auto iris lenses to optimize the amount of light
- Internal synchronization
- Eight privacy mask areas to protect privacy concerns
- Advanced OSD (onscreen display) control
- Signal-to-noise ratio better than 52 dB
- Long life and high reliability
- Isolated switching power 12 VDC and 24 VAC

User guidelines

- Program the camera settings as much as possible before mounting the camera. Take appropriate safety precautions while completing programming after installation.
- Always use a 12 VDC or 24 VAC UL listed Class 2 power supply to power the camera.
- Do not use the camera over the temperature range specifications: -10°C to +50°C (14°F to 122°F)
- If the light source where the camera is installed experiences rapid, wide-variations in lighting, the camera may not operate as intended.

WARNING: To reduce the risk of fire or electronic shock, do not expose the camera to rain or moisture and do not remove the cover or back.

Product description

Figure 1:: Camera description

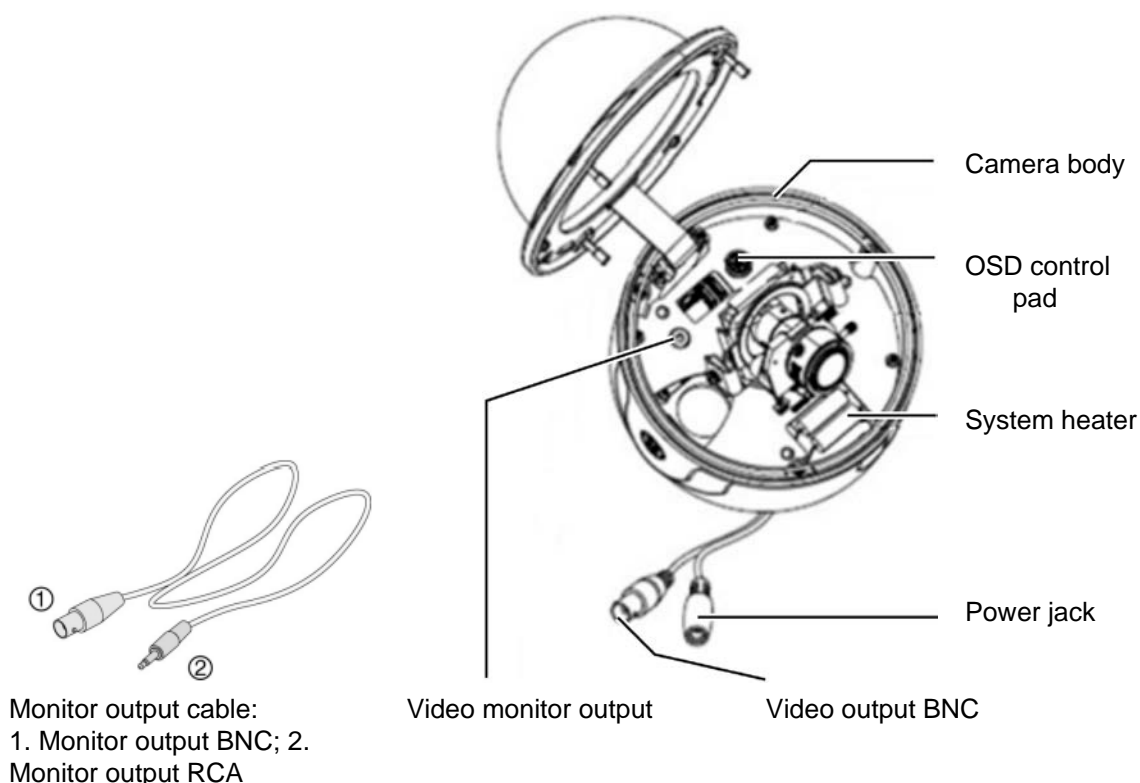

OSD control pad

The onscreen display (OSD) control pad (Figure 3) is a five-direction pad that provides the ability to manually control the camera functions. Table 1 below lists the OSD control pad functions and describes their use.

Figure 2: OSD control pad

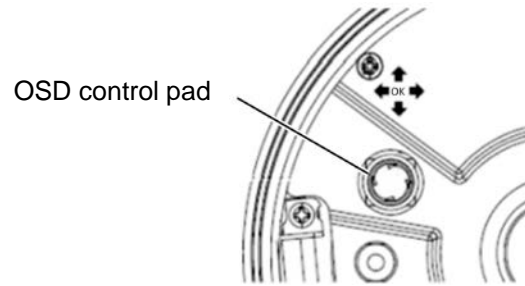

Table 1: OSD control pad functions

Pad directions	Description
Up	Moves the cursor upward to select an item.
Left	Moves the cursor left to select or adjust the options of the selected item.
Right	Moves the cursor to the right to select or adjust the options of the selected item.
Down	Moves the cursor downward to select an item.
Enter	Press the center of the control pad to display the Setup menu. If the selected item has its own menu, press the control pad to enter a submenu. Press the control pad for 2 seconds to save all settings and exit the Setup menu.

Installation

Please check the package contents and make sure that the device in the package is in good condition and all the assembly parts are included.

To install the camera you will need to prepare the mounting surface, mount the camera, make cable connections, adjust the lens and then secure the dome cover securely.

Note: Before installing, please ensure that the mounting surface is strong enough to withstand three times the weight of the camera. If the mounting surface is not strong enough, the camera may fall and cause serious damage.

Mount the camera

Use the ceiling drilling holes template and mark the holes on the ceiling with a pen. Attach the plate with fasteners to the ceiling and then attach the camera body to the plate.

To mount the camera, attach the camera to the mounting surface using the appropriate fasteners.

Connect the cables

To connect the cables:

1. Connect a coaxial cable from the camera's BNC connector to a CCTV monitor or video recording device.
2. Connect the 12 VDC or 24 VAC power supply to the power jack of the camera.

Caution: Check for polarity when using a 12 VDC power supply.

Adjust the lens

The camera is mounted on a pan-tilt-twist (3-axis gimbal) rotating platform so that it is easy to adjust the camera orientation. See Figure 3 on page 6.

Figure 3: Camera adjustment

Platform horizontal adjustment (0 to 180°)

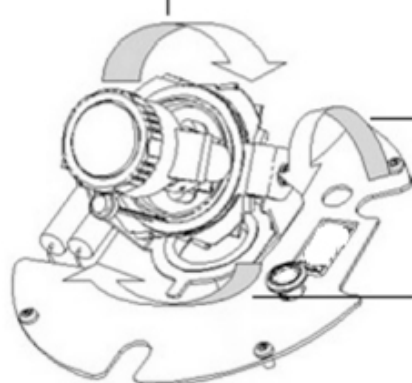

Platform vertical adjustment (0 to 90°)

Rotor horizontal adjustment (0 to 350°)

To adjust the lens:

See Figure 3 above.

1. To adjust the horizontal angle of the platform up to 180 degrees, turn the platform.
2. To adjust the horizontal angle of the rotor up to 350 degrees, turn the rotor on the platform.
3. To adjust the vertical angle of the platform up to 90 degrees, turn the platform.

Adjust the focus and zoom

Figure 4: Zoom and focus adjustment

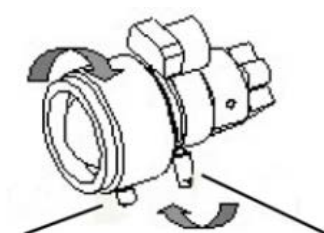

Zoom ring thumbscrew

Focus ring thumbscrew

To adjust the camera zoom and focus:

1. Loosen the zoom ring thumbscrew and turn the zoom ring to set the desired zoom. Tighten the thumbscrew.
2. Loosen the focus ring thumbscrew and turn the focus ring to set the desired focus. Tighten the thumbscrew.

Programming

Once the camera hardware has been installed, the camera can then be configured.

Access the Setup menu

The Setup menu provides access to the camera configuration options. The on-screen display (OSD) is only available in English.

Program the camera by attaching a standard video monitor to the system.

Figure 5: The Setup menu screens



Table 2: Setup menu description

Menu item	Description
Lens	Defines the camera ID, mirror, and digital noise reduction (DNR) set up.
Shutter/AGC	Defines the method of iris control.
Pict Adjust	Defines the image quality functions.
White Bal	Defines the white balance (WB) set up.
WDR	Defines the wide dynamic range (WDR) set up.
NR	Defines the digital noise reduction level.
BLC/HLC	Defines the highlight compensation (HLC) and backlight compensation (BLC) set up.
Day/Night	Defines the day/night (D/N) set up.
EZoom	Enables/disables digital zoom.
DIS	Enables/disables the digital image stabilizer.
Privacy	Defines privacy mask set up.
Motion Det	Defines the motion detection set up.
Sync	Displays the current synchronization mode.
Camera ID	Defines the camera ID displayed on-screen.
Language	Defines the language of the OSD.
Camera Reset	Resets the camera to factory default settings.
Save All	Saves changes made.
Exit	Exits the menu and returns to live mode.

To access the Setup menu:

1. Press the OSD control pad (**Enter**) to access the Setup menu and its submenus.
2. Push the pad up, down, left and right to move between menu options.
3. Press the OSD control pad to select an option.
4. When in a sub menu, select **Return** to return to the previous menu.
5. To save configuration changes, move the cursor to **Save All** at the bottom of the screen and press **Enter**
6. To exit a menu and return to live mode, move the cursor to **Exit** at the bottom of the screen and press **Enter**.

Select the lens type

In the Setup menu, go to **Lens** and select the type of lens used with the camera, Auto or Manual. Select **Manual** for a manual lens and adjust the options manually, or select **Auto** to set the lens type to autoiris. The Autoiris menu appears.

Autoiris menu:

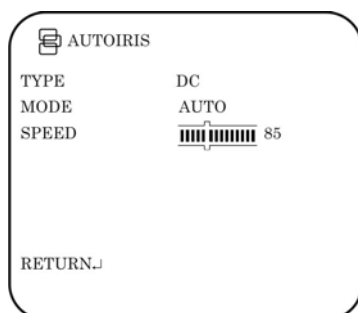

Type: Select the drive mode of the lens. Only DC is available.

Mode: Select the iris control mode. Auto (automatically controlled depending on the light), Open (always open), or Closed (always closed).

Speed: When the mode is set to Auto, select the convergence speed of the iris between 0 and 255.

Set shutter/AGC

In the Setup menu, go to **Shutter/AGC** and select the required iris control option: Manual, Auto or Traffic. Auto is default. The selected menu appears:

Automatic shutter menu:

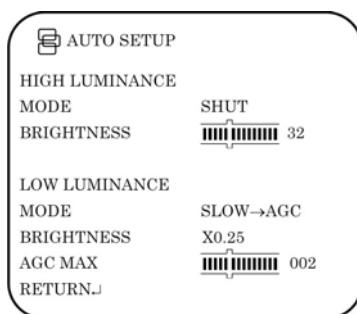

Select the parameters for high and low luminance conditions:

High Luminance: Sets the lux level for bright light conditions such as daylight.

Mode: When lens type is AUTO IRIS, you can choose SHUT+AUTO IRIS or AUTO IRIS mode. When the lens type is manual, only SHUT mode is available.

Brightness: Select the brightness level to which the iris and shutter speed will adjust automatically. The values range from 0 to 255.

Low luminance: Sets the lux level for low light conditions.

Mode: Select Off, AGC, Slow, AGC→Slow, Slow→AGC, or AGC→Slow→AGC.

Brightness: Select the brightness level to X0.25, X0.50, X0.75 or X1.

AGC Max: Adjust the maximum automatic gain control level. The value can range from 0 to 7.

Manual shutter menu:

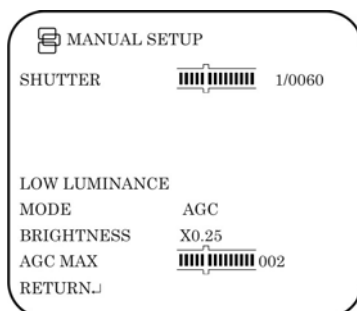

Shutter: Set the manual shutter to 1/60(1/50), 1/100(1/120), 1/250, 1/500, 1/1000, 1/2000, 1/4000, 1/10000, 1/20000 or 1/50000. Select a higher value to see movement and a lower value to see clearer images.

Low luminance: Sets the lux level for low light conditions

Mode: Only AGC available.

Brightness: Select the brightness level to X0.25, X0.50, X0.75 or X1.

AGC Max: Adjust the maximum automatic gain control level. The value can range from 0 to 7.

Traffic shutter menu:

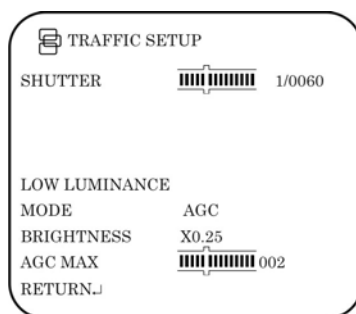

Shutter: Set the manual shutter to 1/60(1/50), 1/100(1/120), 1/250, 1/500, 1/1000, 1/2000, 1/4000, 1/10000, 1/20000 or 1/50000. Select a higher value to see movement and a lower value to see clearer images.

Low luminance: Sets the lux level for low light conditions

Mode: Only AGC available.

Brightness: Select the brightness level to X0.25, X0.50, X0.75 or X1.

AGC Max: Adjust the maximum automatic gain control level. The value can range from 0 to 7.

Adjust the picture characteristics

In the Setup menu, go to **Pict Adjust** and select the options to be modified in the menu.

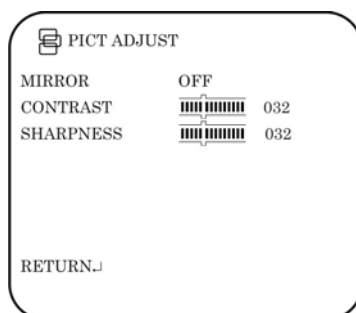

Set the camera image characteristics of the picture: contrast and sharpness. The parameters of each can be set between 0 and 255.

Use the mirror function to flip the camera image so that it is correctly orientated for viewing. The image can be flipped vertically, horizontally or horizontally-vertically (180 degrees). Default setting is Off.

Set white balance

White balance (WB) tells the dome camera what the color white looks like. Based on this information, the dome camera will then continue to display all colors correctly even when the color temperature of the scene changes such as from daylight to fluorescent lighting, for example.

In the Setup menu, go to **White Bal** and select the options to be modified:

Menu Item	Description
ATW	<p>ATW (automatic tracing white balance) limits the color temperature range between 2,500 to 8,500°K to reduce excessive compensation for a large single-color object. Use it to automatically adjust the WB in real time as the lighting conditions change. It can be used for both indoor and outdoor locations.</p> <p>Set the following options:</p> <p>Speed: Set the compensation speed between 0 and 255. A lower value makes the AWB faster.</p> <p>Delay CNT: Set the delay time between automatic adjustments of the AWB. A smaller value increases the frequency rate of AWB.</p> <p>ATW Frame: X0.5, X1.0, X1.5, X2.0. Default is X2.0.</p> <p>Environment: Select Indoor (ATW is compensated for low color temperature such as from incandescent lighting) or Outdoor (ATW is compensated for high color temperature such as from daylight). Default is Indoor.</p>
Push	<p>Like ATW, the Push function continually monitors/analyzes the color temperature of the incoming light and corrects the WB. However, Push has no limits between 1,800 to 10,500°K so it may over-compensate the WB for a large single-color object.</p>
User1	<p>This is a fixed white balance that is user-defined by blue and red gain parameters. Only use this function when there is steady light.</p> <p>Blue-gain from 0 to 255 Red- gain from 0 to 255</p>
User2	<p>This is a second fixed white balance that is user-defined by blue and red gain parameters. Only use this function when there is steady light.</p> <p>Blue-gain from 0 to 255 Red- gain from 0 to 255</p>
Anti CR	<p>The anti-color rolling mode function minimizes the color changes over long periods caused by very small differences between the flicker frequency of non-inverter fluorescent lights and the drive frequency of the image sensor devices.</p>
Manual	<p>Manually adjust the white balance by blue gain only. The red gain is automatically adjusted when the blue gain is changed. Only use this function when there is steady light.</p> <p>Level UP: Press Enter to increase the WB level. Level DOWN: Press Enter to decrease the WB level.</p>
Push Lock	<p>Press Enter to automatically adjust the white balance to the environment and lock it at this value.</p>

Set WDR

Wide dynamic range (WDR) allows you to see details of objects in shadows or details of objects in bright areas of frames that have high contrast between light and dark areas such as the headlights of a passing car.

In the Setup menu, go to **WDR** and select the options to be modified in the menu.

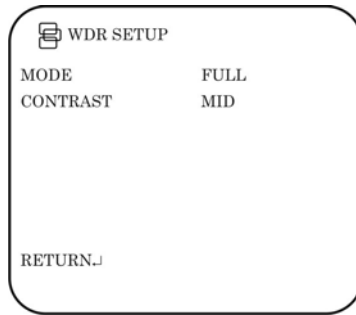

Adjust the mode by pressing left or right to cycle between Full and Normal.

If you select Full Mode, adjust the contrast by pressing left or right to cycle between Low, Midlow, Mid, Midhigh or High.

Set image noise reduction

In the Setup menu, go to **NR Setup** and select the desired digital noise reduction (DNR) levels. 2D/3DNR technology minimizes noise and ghosting. It produces clear images under low light levels.

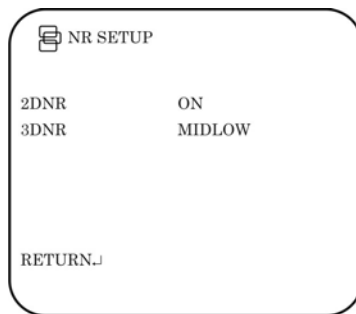

Menu Item	Description
2DNR	Enable or disable the option. Default is On.
3DNR	Select the level of noise reduction from Low, Midlow, Mid, Midhigh, High or Off. High levels can blur the image.

Set HLC and BLC

This feature tells the camera to adjust its total exposure (iris and shutter) in order to ignore the brightest areas of the image, and instead concentrate on darker areas.

HLC (highlight compensation) masks strong light sources, giving darker areas more detail. It is often used to help identify vehicle license plate numbers, for example. BLC (backlight compensation) can improve image quality when the background illumination is high. It prevents the object in the center from appearing too dark. The Clip level option allows you to black out the bright vehicle headlights in the image.

In the Setup menu, go to **HLC/BLC** and select the options to be modified.

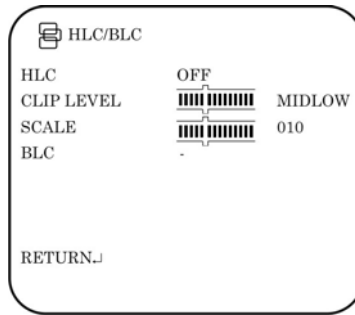

HLC: Enable or disable the option. Default is Off.

Clip level: Adjust the level between from Low, Midlow, Mid, Midhigh, High or Off..

Scale: Adjust the level between 0 and 255.

BLC: Enable or disable the option.

Set Day/Night mode

In the Setup menu, select **Day/Night** to open the day/night menu. The Day/Night mode has two options: Auto and Color.

Select Color to manually set the camera to color (day) mode.

Select Auto so that the camera can automatically switch between day (color) and night (black and white) mode.

Auto mode:

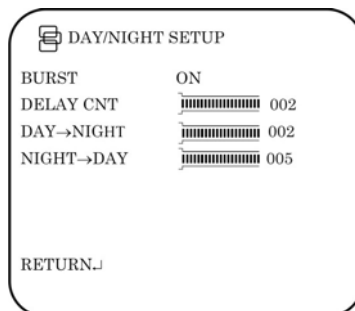

Burst: Enable/disable the color burst component of the video signal when the camera switches to B/W. ON mode maintains the same color signal in B/W so that the video signal provides better compatibility with certain color equipment. OFF mode removes the color burst signal B/W video and increase the total TV lines.

Delay CNT: This is the time in seconds before Day↔Night switches. A long delay response would be used, for example, to avoid switching from Night to Day mode when car headlights pass in front of the camera.

Day→Night: Set the threshold level on how dark it should be before switching from Day to Night mode. Lower (Higher) value makes the camera switched from Day to Night at lower (higher) illumination

Night→Day: Set the threshold level on how light it should be before switching from Night to Day mode.

Caution: If there is a minimal difference between the Day→Night and Night→Day values, then camera may switch between Day and Night mode

Set E-zoom

Digital zoom (E-zoom) is the electronic magnification of a view.

In the Setup menu, select **Ezoom** to open the menu. Select the desired options.

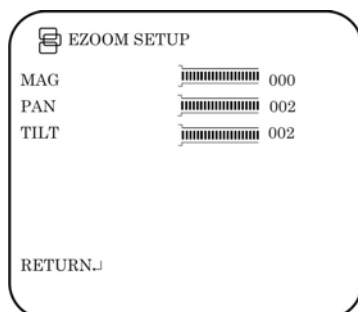

Menu Item	Description
Mag	Adjust the electronic zoom.
Pan	Adjust the horizontal picture.
Tilt	Adjust the vertical picture.

Set DIS

The DIS function (digital image stabilizer) helps to neutralize light camera vibrations.

In the Setup menu, select **DIS** to open the DIS menu. Enable or disable the option.

Set the privacy mask area

In the Setup menu, select **Privacy** to open the privacy mask menu.

Use this function to mask out selected areas of the image. Up to 15 privacy mask areas can be configured, each by size and location on-screen.

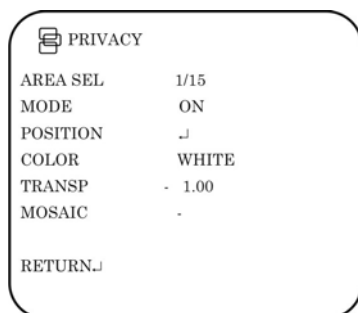

Area Sel: Up to 15 privacy masks can be set.

Mode: Enable or disable the selected mask.

Position: Press **Enter** to get the submenu to set position the mask on screen values.

Color: Select the color of the privacy mask: White, Red, Black, Green, Blue, Yellow, Cyan or Magenta.

Transp: Select the transparency shade of the privacy mask. The privacy mask is fully transparent at value 0.00 and not transparent at 1.00.

Mosaic: Enable this option to see the mask as a mosaic. It is disabled by default.

Note: Only four privacy mask areas can be set when motion detection is enabled.

Set motion detection

In the Setup menu, select **Motion Det** to open the motion detection menu.

Use this function to identify when a moving object passes in front of the camera to activate an alarm. Up to four motion detection areas can be configured, each by size and location on-screen.

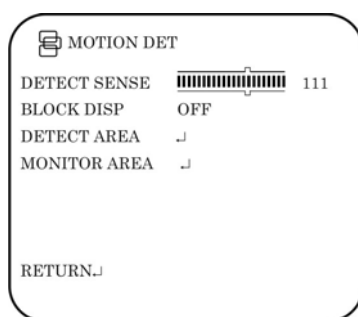

Detect sense: Set the sensitivity level for motion detection. A higher value is more sensitive.

Block Disp: When enabled, any movement detected will be tracked on-screen. Press **Enter** to enable or press the button again to cancel it. The default setting is Off (no motion detection).

Detect Area: Up to four motion-sensitive areas can be set. Set the size and position of each one.

Monitor area: Enable a square grid to be displayed on-screen and set its position. It can only be set if *Block Disp* is enabled.

Display the synchronization mode

In the second Setup menu, go to **Sync** to open the synchronization menu.

Use the **Sync** menu to display the current synchronization mode. Only one option is available: Internal.

Set the camera ID

In the Setup menu, go to **Camera ID** to open its menu. Press Enter to display the menu. The camera ID displayed on-screen can have up to 40 characters.

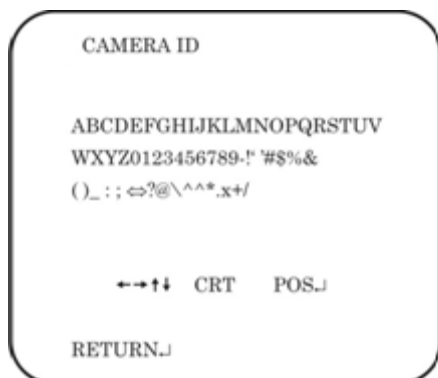

Camera ID input line

Command line

To enter a character, move the cursor to the desired character and press **Enter** to select it. It appears in the input line. Repeat the process until all characters are entered.

To move the character, input position in the input line, move the cursor in the command line to ← or → and press **Enter**.

To clear the input line, move the cursor to CLR and press **Enter**.

To delete a character in the input line, select the character so that it blinks. Then move the cursor to CLR on the command line and press **Enter**.

To position the camera ID on-screen, move the cursor to POS and press Enter. The menu will then disappear on-screen and the camera ID will be displayed on the monitor. Use the menu button to move the camera ID to the desired position. Press **Enter**. The menu will reappear. Select **Return** to return to the previous menu.

Select the language

In the Setup menu, go to **Language** to open its menu.

Use this menu to select the OSD language. Select the desired language. There are only two languages available; English and Japanese.

Reset camera settings

Use this menu to reset the camera settings to factory default.

In the Setup menu, go to **Camera Reset**. Press Enter to reset all camera values to factory default.

Save all changes

Changes are not saved automatically. To save all changes made, move the cursor to the **Save All** option in the Setup menu and press **Enter**.

Specifications

Model	UVD-6130VE-2-P / UVD-6130VE-2-N
Lens type	Varifocal: 2.8 to 10 mm
Power supply	24 VAC / 12 VDC
Current	300 mA Max: 450 mA (heater on)
Power consumption	3 W Max: 10.8 W (heater on)
Operating temperature	-30 to +50 °C (-22 to 122 °F)
Weight	1130 g (2.49 lbs)

Dimensions

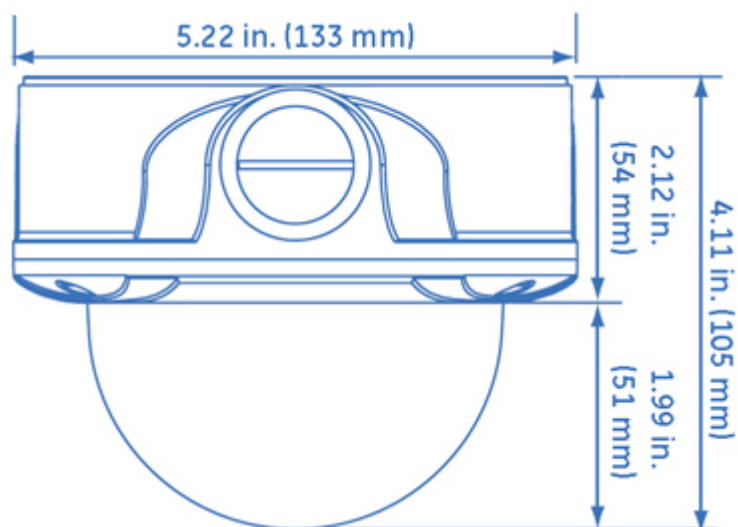

Menu Map

