



AL-1812 Relay Card Installation Instructions

1043366C • August 2006
Copyright © 2006, GE Security Inc.

Introduction

This is the GE *AL-1812 Relay Card Installation Instructions*. The relay card provides low current inputs for open collector outputs, such as the AL-1191/Al-1193 Smart Card Readers.

The relay cards come in groups of four with the following hardware:

- Eight clip-in standoffs
- Four plastic standoffs
- Eight mounting screws
- Eight jumpers



CAUTION: You must be free of static electricity before handling circuit boards. Wear a grounding strap or touch a bare metal surface to discharge static electricity.

Installation

To install the relay card, do the following:

1. Separate the cards into singles or doubles as needed by snapping the cards apart at the score lines (*Figure 1*).

Figure 1. Separating the relay cards

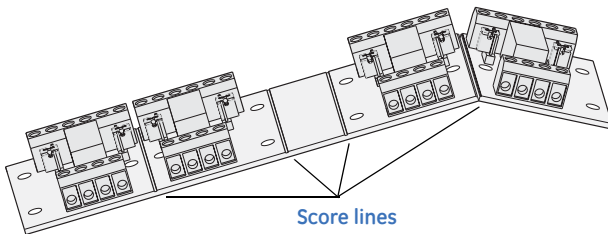

2. Mount the cards in AL-1685 metal housings using the appropriate hardware. *Figure 2* shows the relay card mounting holes.

Figure 2. Mounting holes

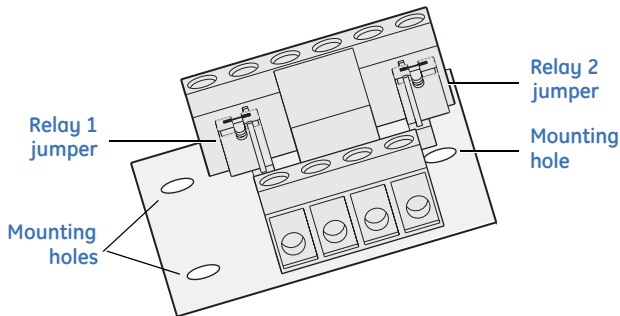

Figure 3 shows a single card mounted in the AL-1685 housing.

Figure 3. Single-card mounting

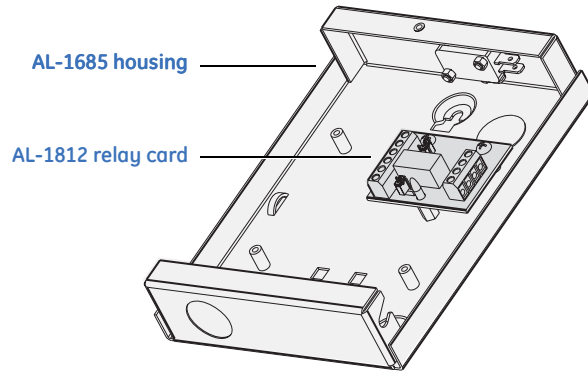
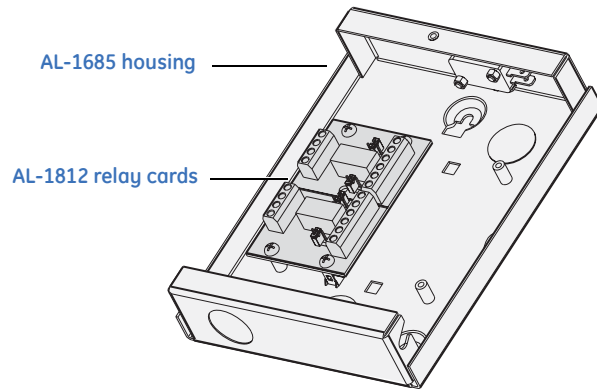

Figure 4 shows a double card mounted in the AL-1685 housing.

Figure 4. Double-card mounting



3. Slide relay 1 and relay 2 contact-programming jumpers (*Figure 2*) over the pins for the required programming setting (*Figure 5*).

Set dry relay contact. Jumper removed or placed on center pin only

Set +12 V on relay comm. Jumper on center pin and plus pin.

Set 0 V on relay comm. Jumper on center pin and minus pin.

Figure 5. Jumper settings

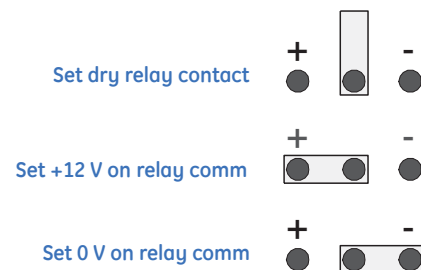

Wiring

Figure 6 shows a typical relay card wiring diagram.

Figure 6. Typical wiring diagram

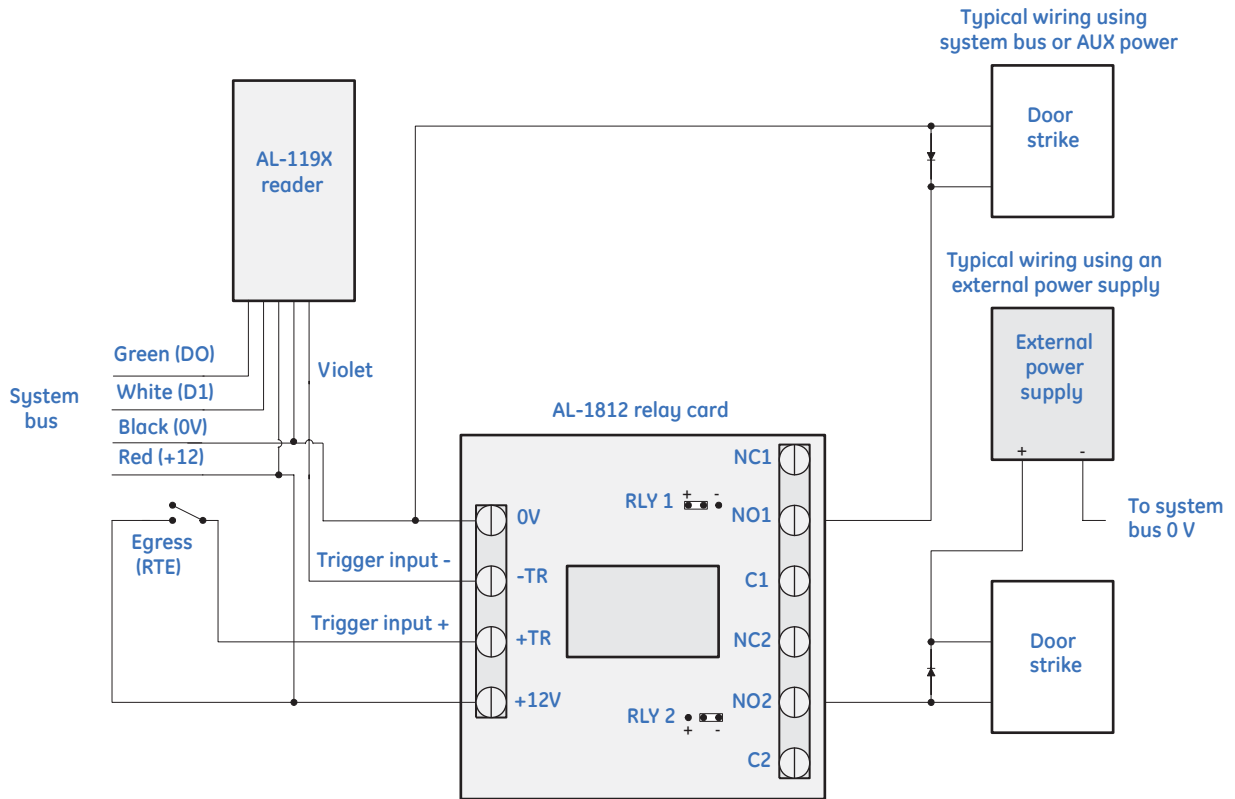

Specifications

Supply voltage	9 to 14 VDC
Current consumption	
Standby	75 mA max.
All relays active	1 A at 0 to 30 VDC
Dimensions	3.1 x 2.0 in. (80 x 52 mm)
Operating temperature	32 to 122°F (0 to 50°C)
Humidity	95% noncondensing

Technical support

Toll-free: 888.GESECURITY (888.437.3287 in the US, including Alaska and Hawaii; Puerto Rico; Canada).
Outside the toll-free area: Contact your local dealer.

www.gesecurity.com