



AL-1206 8-Zone Expansion Card Installation Instructions

1040743C • October 2006
Copyright © 2006, GE Security Inc.

Introduction

This is the GE AL-1206 8-Zone Expansion Card Installation Instructions.

Zone expansion

You can use AL-1206 cards to expand a standard 8-zone DGP or control panel (8- or 16-zone depending on the type) in increments of eight zones up to a total of 32 zones.

There are 16 zones allocated to every DGP address on the Alliance system. If a DGP has 24 or 32 zones (two or three expansion cards fitted), the additional system zone numbers are taken from the following DGP address. If this is done, the next DGP address ceases to exist and is not included to be polled by the control panel.

You must program the unused zone numbers in the system as type 0 (zone disabled) in the zone database. Refer to your control panel documentation for more information.

Table 1 shows the zones allocated to each DGP address in the system.

Table 1. DGP address zones

Address	Zones	Address	Zones
Control panel	1 to 16	DGP 8	129 to 144
DGP 1	17 to 32	DGP 9	145 to 160
DGP 2	33 to 48	DGP 10	161 to 176
DGP 3	49 to 64	DGP 11	177 to 192
DGP 4	65 to 80	DGP 12	193 to 208
DGP 5	81 to 96	DGP 13	209 to 224
DGP 6	97 to 112	DGP 14	225 to 240
DGP 7	113 to 128	DGP 15	241 to 256

Hardware kit

The AL-1206 ships with the following hardware:

- Four 3-position terminal blocks
- Four clip-in standoffs
- Four mounting screws
- One interface cable



CAUTION: You must be free of static electricity before handling circuit boards. Wear a grounding strap or touch a bare metal surface to discharge static electricity.

Installation

To mount the card, do the following:

1. Slide the terminal blocks together (Figure 1).

Figure 1. Terminal block assembly

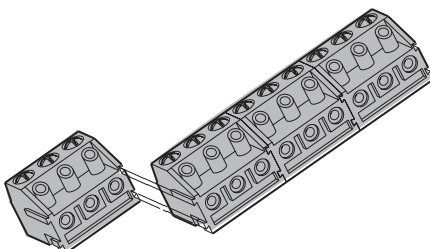

2. Slide the terminal blocks over the pins on the card (Figure 2).

Figure 2. Components

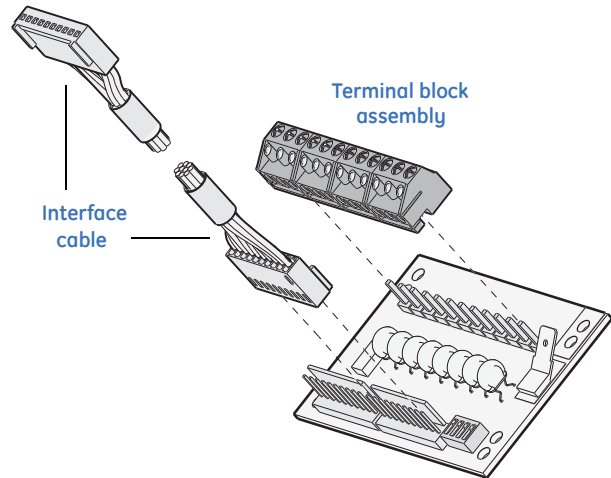

3. Set the DIP switches (see [DIP switches](#)).
4. Mount the card in the enclosure using the four clip-in standoffs and the mounting screws.
5. Plug the interface cable (Figure 2) into the card and into the control panel, DGP, or additional board (see [Wiring](#) on page 2).

Note: The system must be powered down before you plug in the cable.

DIP switches

Table 2 shows the DIP switch settings for the zone numbers this expansion card will use.

Table 2. DIP switch settings

Zone number to use	DIP Switches			
	Switch 1	Switch 2	Switch 3	Switch 4
9 to 16 (first card)	ON	OFF	OFF	OFF
17 to 24 (second card)	OFF	ON	OFF	OFF
25 to 32 (third card)	OFF	OFF	ON	OFF

On a control panel with 16 standard zones, set the first AL-1206 for zones 17 to 24. (You can only use consecutive zone numbers.)

If a DGP or control panel already has AL-1206 cards fitted and the number of zones exceeds 16 while the next DGP number is already being used, you cannot fit any more expansion cards to the DGP or control panel.

Wiring

Figure 3 shows the AL-1206 card wiring connections.

Figure 3. Board connections

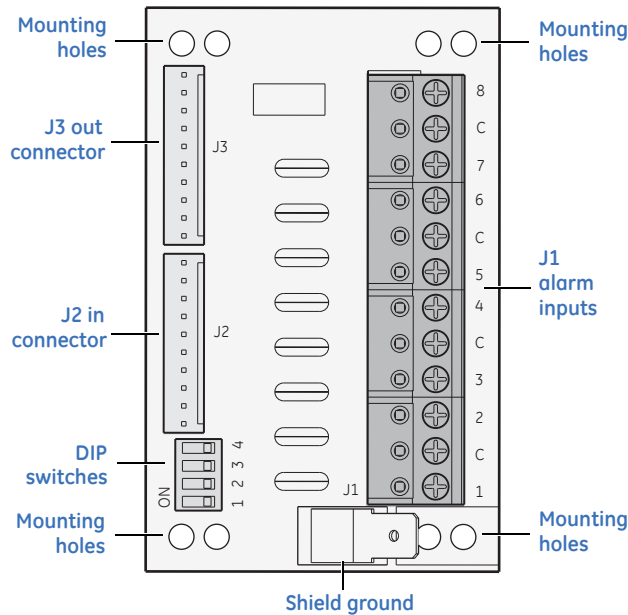

J1. Eight zone (alarm) inputs with common connection.

J2. In connector from the control panel or DGP via the interface cable.

J3. Out connector to the In connector of the next zone expansion board via the interface cable.

Zone EOL resistors

Each zone requires a 2.2, 4.7 (default), or 10 k end-of-line (EOL) resistor. Do not mix EOL resistor values in the system. Refer to your control panel documentation for more information. Figure 4 shows a typical zone EOL resistor connection.

Figure 4. Zone EOL connection

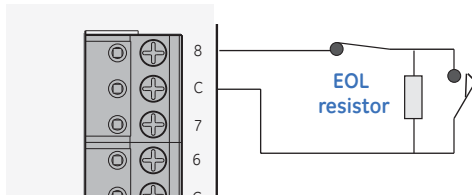

Connection options

Figure 5 shows how to connect two AL-1206 cards to the control panel and how to connect three AL-1206 cards to an eight-zone DGP.

Figure 5. Card connections

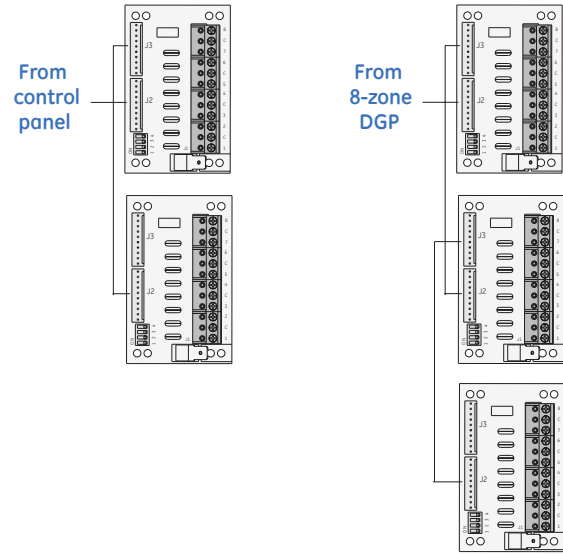

Specifications

Supply voltage	9 to 14 VDC
Current consumption	25 mA max.
Dimensions	3.1 x 2 in. (80 x 52 mm)
Operating temperature	32 to 122°F (0 to 50°C)
Humidity	95% noncondensing
Listings	UL 294 Standard for Access Control System Units UL 365 Standard for Police Station Connected Burglar Alarm Units and Systems UL 609 Standard for Local Burglar Alarm Units and Systems UL 1610 Standard for Central Station Burglar Alarm Units UL 1635 Standard for Digital Alarm Communicator System Units

Technical support

Toll-free: 888.GESECURity (888.437.3287 in the US, including Alaska and Hawaii; Puerto Rico; Canada).
Outside the toll-free area: Contact your local dealer.

www.gesecurity.com