

SECURITY

SYSTEM

INSTALLATION

MANUAL

WIRELESS COMMANDER

ITT

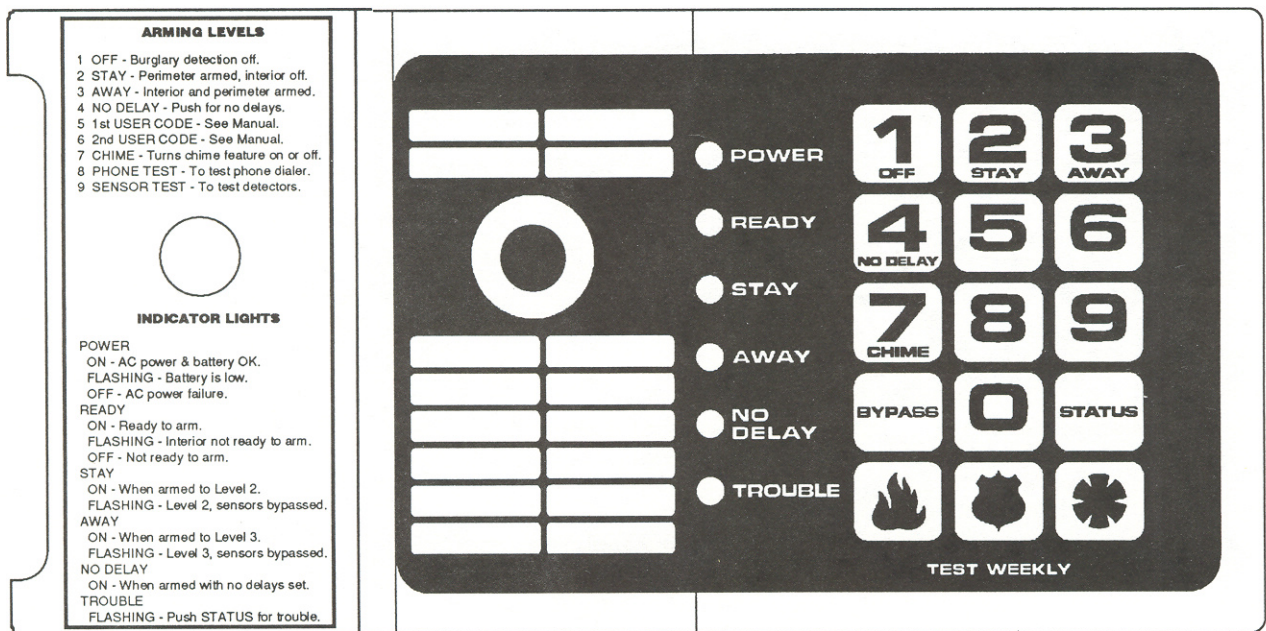
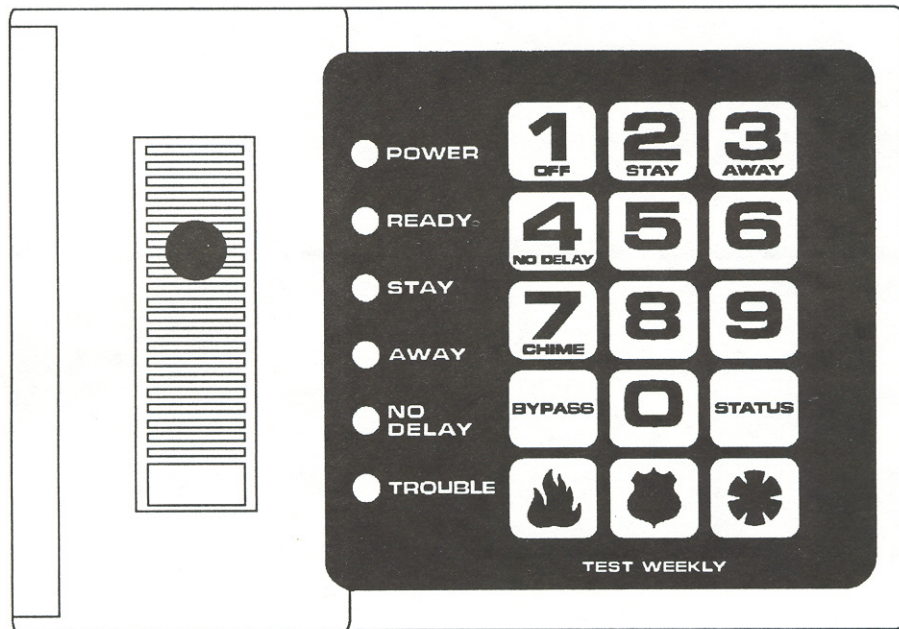

Table Of Contents

Introduction

About The Manual	1
About The System	1
System Features	1
How It Works	1
Alarm Memory	1
Control Panel	2
Wireless Touchpads	2
Wireless Sensor Communication	2
Alkaline Battery Powered Sensors	3
Lithium Battery Powered Sensors	3
Interior/Exterior Sirens	3
Central Station Communication	3
U.L. Listed Systems	4

Installation

Control Panel	5
Wiring Diagram	6
Siren Power Limitations	7
Interior Siren/Piezo	8
Phone Jack Siren	9
Piezo Status Beeper	9
Exterior Siren	10
RJ-31X/CA-38A	11
Power Transformer	12
Power-Up	12

Programming

Memory Clear	13
House Code	13
Duress Code	13
Timeout	13
Entry/Exit Delay	13
Account Number	14
C.S. Phone Number	14
Sensor Numbers	14
Optional Features	15
Pre-Programmed Features	15

Programming (cont)

Normal Mode Programming	15
Primary Access Code	15
Visitor Access Code	15
Secondary Phone Number	16
Multiple User Codes	16
CS-4000 Programming	17
Central Station Sensor Reports	17

Wireless Sensors

Mounting	18
Programming	18
Wireless Touchpad	18

Testing

LED Display	19
Protection Levels	19
Sensor Test	20
System Test	21
Level 3	21
Level 2	21
No Delay	21
Direct Bypassing	21
Indirect Bypassing	21
Fire Panic	22
Police Panic	22
Auxiliary Panic	22
Chime	22
Wireless Touchpads	22

Troubleshooting

Sensors	23
Wireless Touchpads	23
Sirens	23
Communication	23
Control Panel	23

FCC PART 68 NOTICE

This equipment complies with part 68 of the FCC Rules. The label affixed to this equipment contains, among other information, the FCC Registration Number and Ringer Equivalence Number (REN) for this equipment. You must, upon request, provide this information to your telephone company.

1. FCC Registration No: B4Z8NW-11892-AL-R
2. Ringer Equivalence: 0.3B

The REN is useful to determine the quantity of devices you may connect to your telephone line and still have all those devices ring when your telephone number is called. In most, but not all areas, the sum of the REN's of all devices connected to one line should not exceed five decibels (5.0 dB). To be certain of the number of devices you may connect to your line, as determined by the REN, you should contact your local telephone company to determine the maximum REN for your calling area.

The FCC requires the connection to the telephone network be made through Uniform Service Orders Code (USOC) type jacks (RJ31X or RJ38X) supplied by the telephone company.

If your telephone equipment causes harm to the telephone network, the telephone company may discontinue your service temporarily. If possible, they will notify you in advance. If an advance notice is not practical, you will be notified as soon as possible.

Your telephone company may make changes in its facilities, equipment, operations or procedures that could affect the proper functioning of your equipment. If they do, you will be notified in advance to give you an opportunity to maintain uninterrupted telephone service.

This product is not field repairable. However, sections of this manual describe troubleshooting steps which one can take in the event of equipment problems.

This equipment may not be used on coin service lines provided by the telephone company.

Connections to party lines are subject to state tariffs. Contact your local telephone company if you plan to use this equipment on party lines.

The installation of this product does not require any connections or changes to the internal wiring of other registered terminal equipment.

The installation of this product does not require any connections or changes which affect the exterior of other registered terminal equipment.

CANADA NOTICE

The Canadian Department of Communications label identifies certified equipment. This certification means that the equipment meets certain telecommunications network protective, operational and safety requirements. The Department does not guarantee the equipment will operate to the user's satisfaction.

Before installing this equipment, users should ensure that it is permissible to be connected to the facilities of the local telecommunications company. The equipment must also be installed using an acceptable method of connection. In some cases, the company's inside wiring associated with a single line individual service may be extended by means of a certified connector assembly (telephone extension cord). The customer should be aware that compliance with the above conditions may not prevent degradation of service in some situations.

Repairs to certified equipment should be made by an authorized Canadian maintenance facility designated by the supplier. Any repairs or alterations made by the user to this equipment, or equipment malfunctions, may give the telecommunications company cause to request the user to disconnect the equipment.

Users should ensure for their own protection that the electrical ground connections of the power utility, telephone lines and internal metallic water pipe system, if present, are connected together. This precaution may be particularly important in rural areas.

CAUTION! Users should not attempt to make such connections themselves, but should contact the appropriate electric inspection authority, or electrician, as appropriate.

The Load Number (LN) assigned to each terminal device denotes the percentage of the total load to be connected to a telephone loop which is used by the device, to prevent overloading. The termination on a loop may consist of any combination of devices subject only to the requirement that the total of the Load Numbers of all the devices does not exceed 100.

LOAD NUMBER: 5 ACCEPTABILITY NUMBER: 867 K 718

INTRODUCTION

About The Manual

This manual details the installation, programming and operation of the Central Processing Unit (CPU) and its associated equipment including the following:

1. Wireless Touchpads
2. Interior/Exterior Sirens

This installation manual is intended to serve as a reference document for the installer of this equipment. ITI strongly urges that the first time reader of this manual take the time to read it "cover to cover" before attempting to install, service or use the system. From then on, it may be used as a reference document when a question arises.

The following section (About The System) will describe the basic operation of the CPU and related components to familiarize the first time installer. The Programming and Testing sections will go into more detail of the system's capabilities.

Note: Upon initial power-up, the system's Access Code automatically defaults to **1 2 3 4**. Therefore, this code will appear throughout all sections of this manual. Changing the Access Code will be covered later once the installer has become more familiar with system operation.

ABOUT THE SYSTEM

System Features

- CPU responds to user commands with various tones from built-in speaker.
- Monitors up to 17 individual Lithium and/or Alkaline battery powered sensors.
- Built-in touchpad programs system features into the control panel.
- Will accept up to SIX (6) separate User Access Codes.
- Opening/Closing reports by user number.
- Voice message identifies sensor number and type after disarming from an alarm condition.
- Built-in Digital Communicator reports Alarms to Central Station by zone number.
- Alarm Memory stores alarm reports.
- Two (2) remote Touchpad options available:
 1. Wall Mount Wireless Touchpad (WT)*
 2. Handheld Touchpad (HHTP)
- Back-up battery automatically tested underload, daily.

* Not U.L. listed.

How It Works







The user sets the Control Panel to a specific level of protection using the built-in touchpad or a Wireless touchpad. Supervisory test signals are received every 69 minutes from various transmitters such as Smoke, Door/Window, Passive Infrared (PIR) and Sound sensors. When a sensor is activated, it transmits a signal to the Control Panel. The Control Panel speaker and all interior and exterior sirens emit an alarm sound. If the Control Panel is connected to the phone line it can send the alarm information to a Central Monitoring Station.

Alarm Memory

After an Alarm condition occurs, the LEDs on the control panel begin scrolling to indicate that the Alarm information is now in memory. After the system is disarmed, the control panel speaker will announce the sensor number and sensor type that was tripped. Alarms in memory can be reviewed by pressing the STATUS button for 3 seconds or by entering the Access Code + STATUS. Alarm Memory will store all alarms which occur in a single armed period. These alarms will remain in memory until the system is re-armed and a new alarm condition occurs.

Control Panel

The Control Panel processes information from all wireless devices within the system and from the built-in touchpad. The touchpad allows the user to enter any and all commands to operate the system. Six (6) LEDs indicate various conditions of the system, described below. A built-in speaker provides Alarm and Trouble voice messages. The Control Panel can be connected to the on-premise phone line for Central Station reporting of Alarm and/or Trouble conditions. A 9vdc alkaline battery supplies emergency power for the unit in case of an AC power failure.

 POWER	POWER (Green) ON - AC power ON, back-up battery good. OFF - AC power OFF, back-up battery good. FLASHING - AC power ON, back-up battery bad.	AWAY (Red) ON - System armed to Level 3, full protection. FLASHING - System armed to Level 3 with sensor(s) bypassed.
 READY	READY (Green) ON - Perimeter and Interior sensors ready to arm. OFF - Perimeter and Interior sensors are open.	NO DELAY (Red) ON - Delays are not active. OFF - Delays are active (normal).
 STAY	STAY (Red) ON - System is armed to Level 2, perimeter protection only. FLASHING - System is armed to Level 2 with sensor(s) bypassed.	TROUBLE (Red) OFF - Normal operation. FLASHING - When something is not operating properly. Press STATUS button for voice announcement of problem.
 AWAY		
 NO DELAY		
 TROUBLE		Note: The TROUBLE and POWER LEDs will both flash when the back-up battery is bad.

Wireless Touchpads

Wireless Touchpads provide added customer convenience by allowing the user to arm, disarm or bypass sensors without having to be at the Control Panel. Confirmation of arming commands are signalled by two (2) *beeps* (Level 2) or three (3) *beeps* (Level 3) from the built-in speaker and any other hardwire interior sirens. Disarming (Level 1) is confirmed by one (1) long *beep*. When bypassing sensors from Wireless Touchpads, the Control Panel will announce the *bypassed sensor number* for confirmation.

The Wall Mount Wireless Touchpad can be mounted in areas such as Entry/Exit locations. This allows the Control Panel to be mounted in a more secure location on the premises where it is not as likely to be tampered with or damaged by an intruder.

The Handheld Touchpad is a portable unit which can be carried and used anywhere on the premises without having to go to the Control Panel or a Wall Mount unit.

Wireless Sensor Communication

Supervised wireless sensors transmit a radio signal every 69 minutes to the control panel. The information in this radio signal includes the House Code, Sensor Number, Sensor Type, Open/Close Status, and Tamper/Low Battery condition. Door/Window, Recessed Door/Window, Shock, Smoke, Heat, Passive Infrared (PIR) and *Portable/Pendant Panic sensors are all supervised.

Note: Only the models 60-135 and 60-151 Door/Window sensors, 60-106 Smoke sensor and 60-389 are U.L. Listed and can be used with the control in U.L. Listed applications.

The control panel must receive at least one (1) supervisory signal from each sensor in a 12 hour period. Should the panel not receive a supervisory signal from a sensor during that time, the TROUBLE LED will begin flashing. Pressing the STATUS button will initiate a voice message which will announce "**HELLO, ALARM SYSTEM IS OFF, SENSOR nn FAILURE.**" (nn = sensor number).

Door/Window and Shock sensors have a built-in Tamper switch that activates whenever the sensor cover is removed, causing a "Tamper" signal to be sent to the control panel. If the system is armed to level 2 or 3, removing a sensor cover will cause the system to go into alarm. If the sensor is programmed as a 24 hour device and the cover is removed when the system is set to level 1, an alarm condition would also occur.

* Even though Portable/Pendant Panic sensors transmit supervisory signals, the Control Panel does not require receiving this signal every 69 minutes from these devices. Therefore, they can be taken off the premises without compromising the integrity of the system, unlike the other supervised sensors described above.

Alkaline Battery Powered Sensors

Smoke, Heat, some PIR sensors and Portable Panic Buttons operate with 9 volt alkaline batteries which are monitored by the control panel every time they transmit a supervisory signal. Battery life in these sensors is typically 12-18 months. When battery voltage drops to approximately 7.4vdc, these sensors will transmit a LOW BATTERY signal to the control panel. The TROUBLE LED will begin flashing and pressing the STATUS button will initiate the voice message **"HELLO, ALARM SYSTEM IS OFF, SENSOR nn LOW BATTERY."**

Lithium Battery Powered Sensors

Door/Window, Recessed Door/Window, Shock, some PIR sensors, Pendant Panic sensors and Wireless Touchpads all operate with 3.6vdc lithium batteries. Battery life in these sensors is 5-8 years. Because of their low voltage and low current characteristics these batteries cannot be monitored like alkaline types. Should a lithium battery fail in one of these sensors, that device will cease to transmit supervisory signals to the control panel. The TROUBLE LED will flash and pressing the STATUS button will initiate the voice message **"HELLO, ALARM SYSTEM IS OFF, SENSOR nn FAILURE."**

Wireless Touchpads with lithium batteries that fail will no longer emit a short *beep* when their digits are pressed and Pendant Panic sensors will not function at all.

IMPORTANT! The system should be tested at least once a week to ensure all sensors are operating properly.

Interior Sirens

Interior sirens emit Status and Alarm sounds only and are not capable of any voice annunciation.

Phone Jack Siren (Part No. 60-108)*

(Not approved for use in Canada.)

This unit is a combination modular phone jack and piezo. It is designed to replace an existing phone jack and take advantage of spare or unused phone wiring for connection to the piezo.

Interior Siren/Piezo (Part No. 60-278)

This combination unit produces both low volume status sounds and high volume alarm sounds. Ideal locations include hallways common to bedroom areas.

Piezo Status Beeper (Part No. 30-006)*

This device can be mounted in remote areas such as a garage.

* Output of these sirens is less than 85dB and should not be relied on as the only sound source.

Exterior Sirens

Exterior sirens emit Alarm sounds only and are not capable of any voice annunciation.

Hardwire Exterior Siren - Low Current (Part No. 13-046)

This siren uses less than 115mA of current, yet provides a very high output.

CAUTION! DO NOT attempt to connect any other type of siren unless you know it operates between 6-14vdc and does not draw more than 150mA of current. Failure to observe this may cause permanent damage to the Control Panel.

Note: Only the Part No. 13-046 is acceptable for use in a U.L. Listed application.

Central Station Communication

The built-in communicator transmits Alarm and Trouble signals to the central station by sensor number. The Control Panel requires a 5 digit account number and will accept phone numbers from 7 to 14 digits in length. The compatible receiver is the U.L. Listed ITI Model CS-4000.

U.L. LISTED SYSTEMS

The minimum system configurations for the applicable U.L. listed systems are as follows:

Basic System

Model 60-419 Control Unit
Model 22-035 Power Transformer* (Basler No. BE23149-001)
Model 13-046 Exterior Siren
* In Canada use ITI Model 22-064 or Basler No. BE23149-002.

Household Fire Alarm

Basic system above and including Listed Model 60-106 Smoke Sensor.

Household Burglary System

Basic system above and including Listed Models 60-135 or 60-151 Door/Window sensors.

(These devices require that the digital alarm communicator be programmed. The 60-419 is compatible with the Listed ITI Model CS-4000 receiver.)

Miscellaneous Signalling

All above systems can use the Listed Model 60-389 wireless touchpad.

INSTALLATION

Control Panel Part No. 60-419

PRELIMINARY CONSIDERATIONS

In General:

- Discuss the installation requirements and applications with the customer.
- Locate the CPU in a controlled environment (32°F to 95°F).
- The location of the CPU should be secure, yet easily accessible to the customer.
- Good locations include areas near Entry/Exit or behind the master bedroom door.
- Verify the availability of a 110V non-switched AC outlet for the power transformer.

For Optimum Range:

- Centrally locate the CPU with respect to all sensors whenever possible.
- Avoid locations with excessive metal, foil wallpaper, pipes and electrical wiring.
- Only a plastic type gang box is to be used when mounting to a 3 gang box for flush mount installations.
- Locate sensors within a 50' radius of the CPU location if possible. Even though the system has an open field range of 250' to 300', use 50' as a starting point inside a building.
- The antenna shall be fully extended either horizontally or vertically from the mounting enclosure/bracket.

MOUNTING

Flush Mount to 3 Gang Box (Must be plastic only.)

1. Remove the Tamper screw at the bottom of the control panel.
2. Separate the mounting plate from the back of the control panel.
3. Place the mounting plate on the gang box so that the *round* holes line up with the holes on the gang box.
4. Secure the mounting plate to the gang box using at least 4 #6 x 1/2" flat head screws.

Note: Flat head screws **must** be used or the Control Panel may not seat properly on the mounting plate.

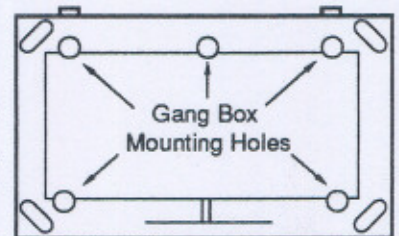

Flush Mount without 3 Gang Box

(This method shall not be used in U.L. Listed applications.)

1. Remove the Tamper screw at the bottom of the control panel.
2. Separate the mounting plate from the back of the control panel.
3. Place the mounting plate at the desired location on the wall and mark the 4 *wall mounting holes*.
4. Use the proper anchors and crews to secure the mounting plate to the wall.
5. Carefully cut a hole in the wall using the inner edges of the mounting plate as a guide. This will allow the back of the Control Panel to fit inside the wall.

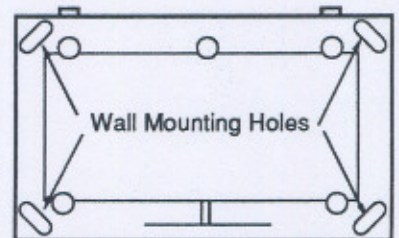

Surface Mount with Optional Back Box (Part No. 44-529-10)

1. Remove the Tamper screw at the bottom of the control panel.
2. Separate the mounting plate from the back of the control panel.
3. Place Back Box at desired location on the wall. Mark the *back box mounting holes* and the *wire feed holes*.
4. Cut a hole where you marked the *wire feed holes*. Then, install anchors where you marked the *back box mounting holes* and insert screws half way into them.
5. Pull all wires out of the hole you cut in the wall and feed them through the *wire feed holes*.
6. Using the *back box mounting holes*, hang Back Box on screws and tighten them.
7. Line up *back plate mounting holes* on Back Plate with *back plate mounting holes* on Back Box. Use the four flat head screws supplied with the Back Box to secure the back plate to it.

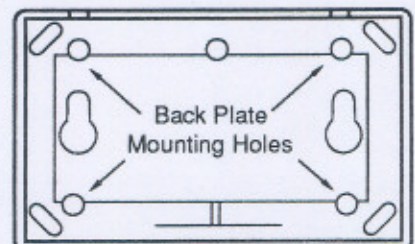
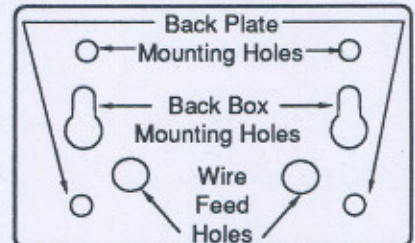

CONTROL PANEL Part No. 60-419

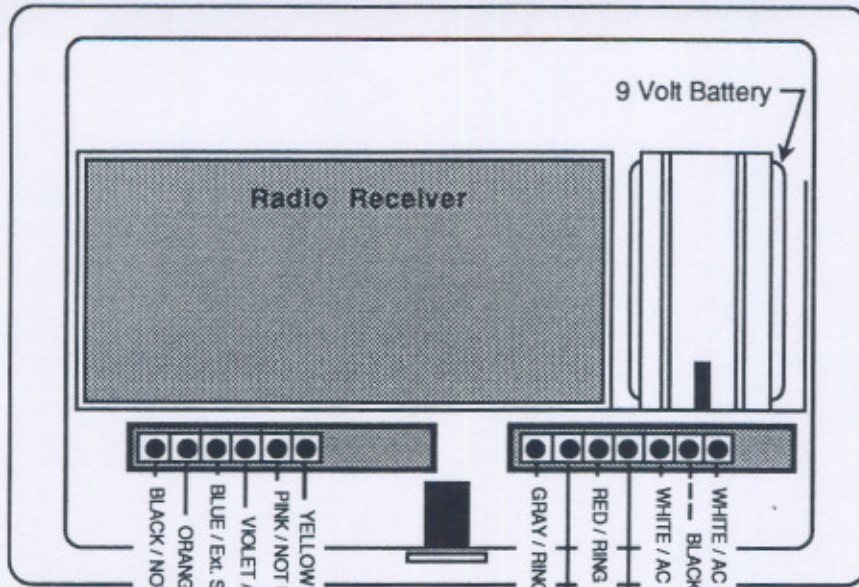

Phone Jack Siren Part No. 60-108
(Not approved for use in Canada.)



(See note.)

Exterior Siren-Low Current
Part No. 13-046



Interior Siren/Piezo
Part No. 60-278 (See note.)

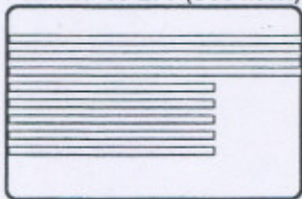

NOTE: Not intended for use in U.L. Listed applications.

Class II Transformer Part No. 22-035
(CSA Part No. 22-064)

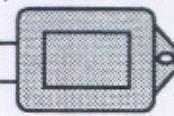

(Connect transformer to a 24 hour unswitched AC outlet.)

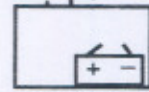

Optional 12VDC/250mA Power Supply can be used instead of Class II Transformer.

WARNING! Do Not use optional power supply in addition to Class II Transformer. The optional power supply shall not be used in U.L. Listed applications.

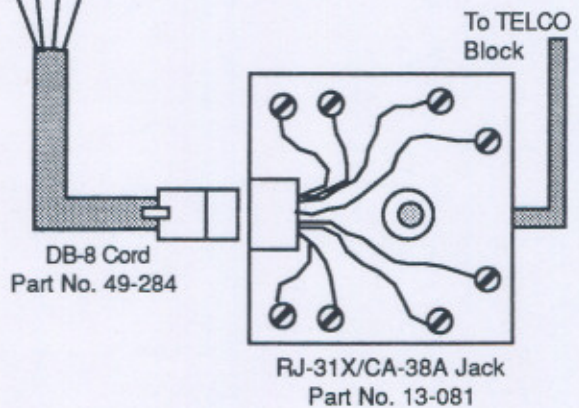

SIREN POWER LIMITATIONS

The Control Panel allows a total of 150 mA of current draw. Any attempt to draw more than 150mA by connecting too many sirens or, by connecting incompatible sirens may cause permanent damage to the Control Panel.

The following is a listing of all compatible sirens for the Control Panel, available from ITI. Also listed are all the possible combinations of these sirens with respect to the 150mA current draw spec. See pages 8-10 for installation and hook-up of these sirens.

INTERIOR SIRENS (Non-U.L. Applications)

Model	Description	Current Draw
60-278	Interior Siren/Piezo	75mA
60-108	Phone Jack Siren (Not approved for use in Canada.)	10mA
30-006	Piezo Status Beeper	10mA

EXTERIOR SIREN CIRCUIT

Model	Description	Current Draw
13-046	Exterior Siren-Low Current	115mA

WARNING! This is the only compatible exterior siren for the 60-419 control panel. In U.L. Listed applications, only one siren shall be used.

SIREN COMBINATION OPTIONS

(Non-U.L. Applications)

	Model	Max. Qty.	Unit Draw	Sub Totals	Combination Total
a.	60-278	2	75mA (each)	150mA	150mA
b.	60-278	1	75mA	75mA	145mA
	60-108	7*	10mA (each)	70mA	
c.	60-278	1	75mA	75mA	145mA
	30-006	7*	10mA (each)	70mA	
d.	13-046	1	115mA	115mA	145mA
	60-108	3†	10mA (each)	30mA	
e.	13-046	1	115mA	115mA	145mA
	30-006	3†	10mA (each)	30mA	

* Any combination of models 60-108 and 30-006 not exceeding 7 can be used in **b** or **c**.

† Any combination of models 60-108 and 30-006 not exceeding 3 can be used in **d** or **e**.

INTERIOR SIREN/PIEZO Part No. 60-278*

* Not intended for use in U.L. Listed applications.

OVERVIEW

The Interior Siren/Piezo is a combination unit which produces both low volume status sounds and high volume alarm sounds. The unit does not emit any voice messages.

PRELIMINARY CONSIDERATIONS

- Install the unit where Alarm sounds need to be heard.
- An ideal location is in a hallway common to bedroom areas.
- Current draw of the Interior Siren/Piezo is 75mA.
- Maximum current draw allowed by the control panel is 150mA.
- Use 4 conductor, 22 gauge or greater stranded wire.

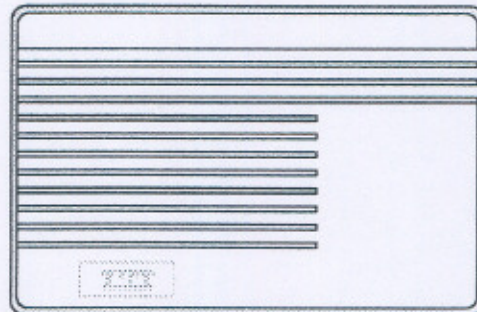

INSTALLATION

1. Run your cable from the control panel to the desired siren location.
2. Remove the front cover of the siren by removing the two bottom screws. Remove the four screws which secure the piezo assembly and separate the assembly from the base.
3. Feed your cable through the circular cut-out on the back of the base. Mount the base to the wall with proper anchors and screws at the two "keyhole" locations on the base. Feed your cable through the *larger round hole* of the piezo assembly, then resecure the piezo assembly to the base.
4. Connect the two wires from the double piezo board to the two left screws, and the single piezo wires to the two right screws.
5. Follow the wiring diagram at the right for proper connections to the control panel.
6. Place the front cover back on the unit and secure it with the two bottom screws.

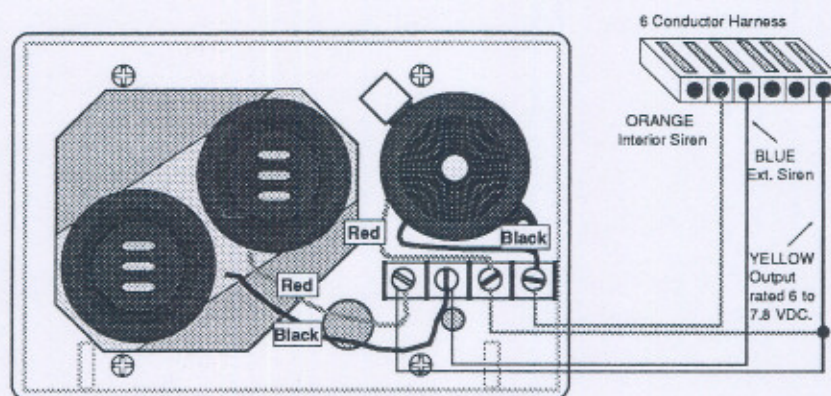

The *double piezos* activate for Fire, Burglary and Auxiliary alarms only. The *single piezo* activates for both Status/Trouble and Alarm sounds.

Note: When installing 2 Interior Siren/Piezo units, *the connections to the piezos must be in parallel with polarity observed to maintain the siren volume.*

WARNING! When installing 2 Interior Siren/Piezo units, *no other sirens may be connected to the control panel. See page 7 for Siren Power Limitations.*

PHONE JACK SIREN Part No. 60-108*

* Not intended for use in U.L. Listed applications.

OVERVIEW

The Phone Jack Siren is an interior sounding device which emits Alarm and Status tones. The unit does not emit any voice announcements. It is intended to replace an existing phone jack and make use of any spare wires in the existing phone line for connection to the piezo.

PRELIMINARY CONSIDERATIONS

- Install the unit where Alarm sounds need to be heard.
- Ideal locations include bedrooms, hallways and garages.
- Current draw of the piezo is 10mA.
- Maximum current draw allowed by the control panel is 150mA.

INSTALLATION

Follow the wiring diagram on page 11 to install the Phone Jack Siren. Be sure to check the spare phone cable wires you are using at each existing jack. Splice these wires back together at all phone jack locations if they are cut or the piezo will not work.

ATTENTION CANADIAN DEALERS! The Phone Jack Siren is not approved for use in Canada.

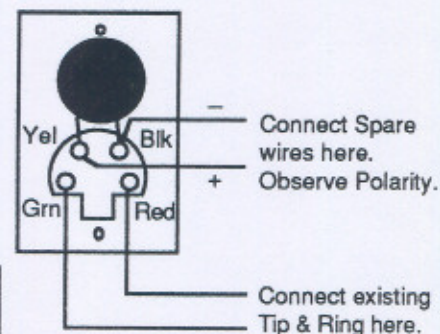
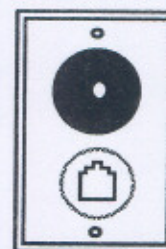

PIEZO STATUS BEEPER Part No. 30-006*

* Not intended for use in U.L. Listed applications.

OVERVIEW

The Piezo Status Beeper is an interior sounding device which emits Alarm and Status tones. The unit does not emit any voice announcements.

PRELIMINARY CONSIDERATIONS

- Install the unit where Alarm sounds need to be heard.
- Ideal locations include bedrooms, hallways and garages.
- Current draw of the piezo is 10mA.
- Maximum current draw allowed by the control panel is 150mA.
- Use 2 conductor, 22 gauge or greater stranded wire.

INSTALLATION

1. Run your cable from the Control Panel to the desired location for the device.
2. Make connections according to the diagram at right. Use the appropriate insulated crimp connectors for all splices. Polarity **must** be observed.
3. Push crimped connections inside the wall and attach the Piezo Status Beeper to the wall using appropriate anchors and screws.

Note: For a more attractive installation, the Piezo Status Beeper can be mounted onto a single gang cover plate and then secured to the wall or a single gang box.

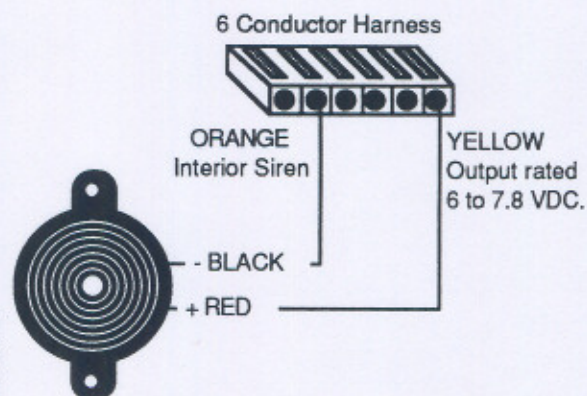

EXTERIOR SIREN Part No. 13-046

OVERVIEW

The Exterior Siren is designed to produce loud alarm sounds in large indoor or outdoor areas. The device draws only 115mA of current and has a weatherproof housing.

This low current siren was designed exclusively for the Control Panel and is the *only* compatible exterior siren available for the Control Panel.

In U.L. Listed applications, the siren shall be mounted indoors.

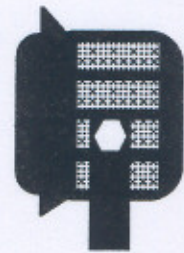

PRELIMINARY CONSIDERATIONS

- Mount the Exterior Siren where alarm sounds can be heard but an intruder cannot detect its presence.
- Ideal locations include in attics next to vents.
- Use 2 conductor, 22 gauge or greater stranded wire from the Control Panel to the siren.
- Maximum 1 Exterior Siren per Control Panel.

INSTALLATION

1. Remove the 2 bolts and washers that secure the mounting bracket to the siren housing.
2. Place the mounting bracket at the desired location and mark the mounting holes. Secure the mounting bracket to the surface using the appropriate anchors and screws.
3. Attach the siren housing to the mounting bracket with the washers and bolts.
4. Aim the siren in the desired direction and securely tighten the bolts.
5. Connect the siren wires to the 6 conductor harness as shown in the diagram at the right. Polarity must be observed.

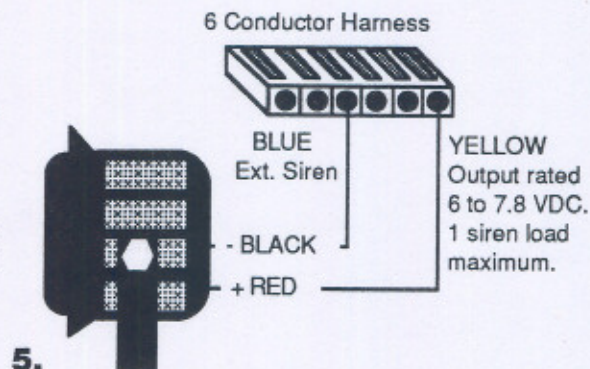
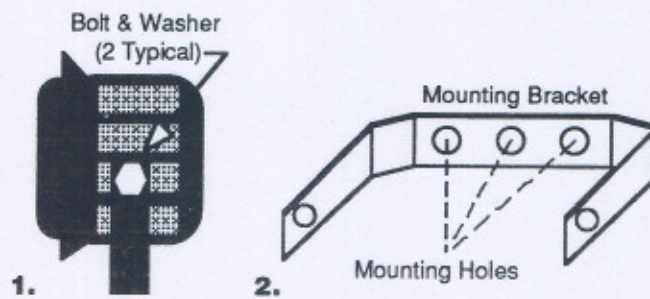

The RJ-31X / CA-38A Part No. 13-081

The Control Panel phone line connections for proper line seizure are the same as for any other alarm panel. To minimize phone line down time, study the diagram below before attempting the hook up.

For added convenience ITI has fabricated a special DB-8 cord for the Control Panel. The cord includes two molex connectors for fast and easy slide-on phone line connections to the back of the Control Panel.

ATTENTION CANADIAN DEALERS! The Phone Jack Siren (part #60-108) is not approved for use in Canada.

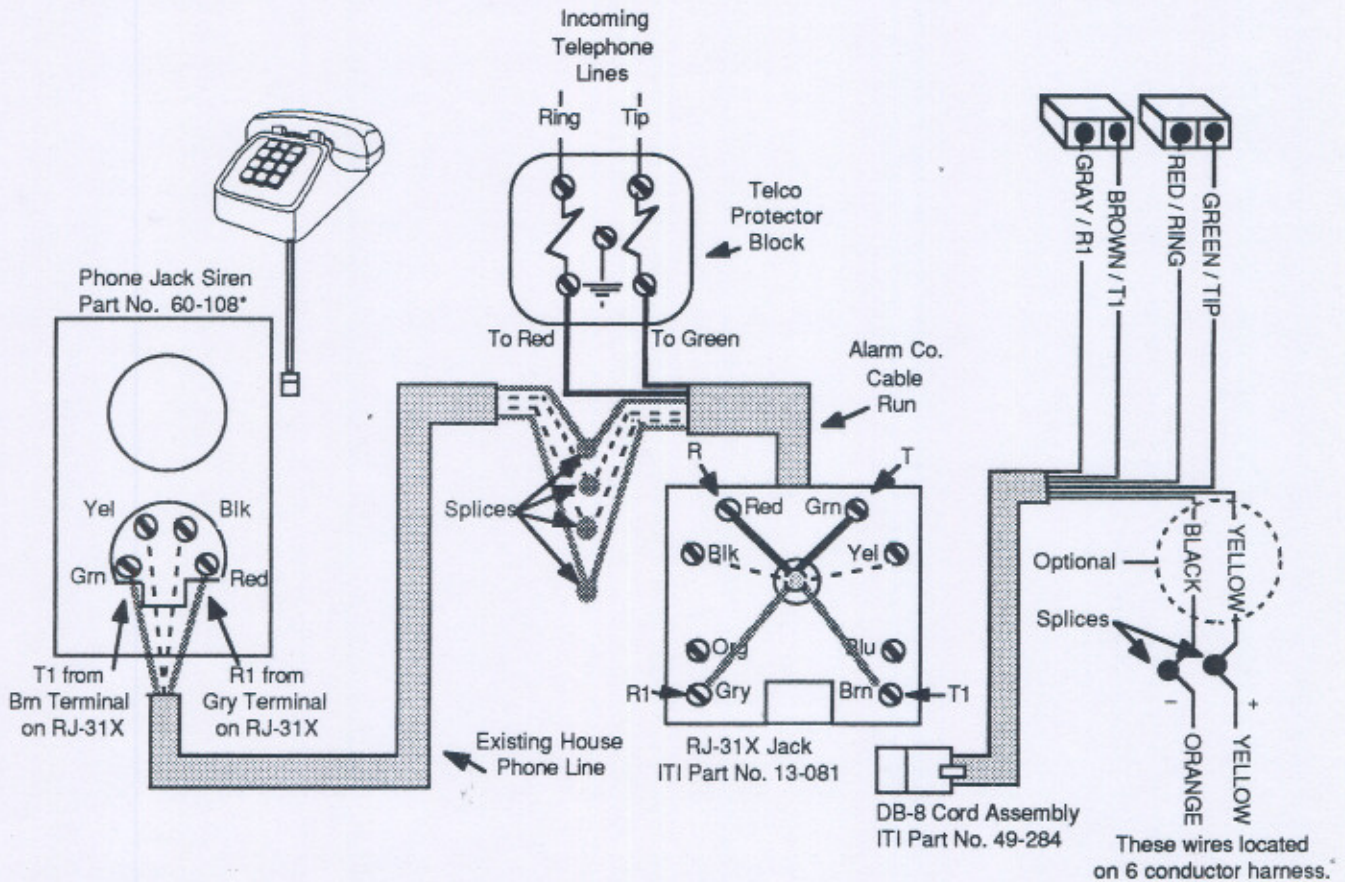

* The Phone Jack Siren shall not be employed in U.L. Listed applications.

1. Locate the incoming telephone line protector block and run a 4 conductor cable (or 6 conductor if you plan to use Phone Jack Sirens) from there, to the RJ-31X jack. The jack should be located within 5 feet of the CPU.
2. Connect your cable to the jack as shown above.
3. Make the necessary connections at the protector block. Polarity **must** be observed. All splices must be weather proof and insulated.
4. If Phone Jack Sirens are to be installed, connect the remaining 2 wires of **your** 6 conductor cable to an unused pair of wires in the existing phone cable.
5. When all wiring is completed, **check all phones** for proper operation with the DB-8 cord disconnected from the RJ-31X jack. Incorrect wiring and reversed polarity are common mistakes. Refer to the Troubleshooting section if you experience any problems.

Note: Proper line seizure means the CPU is ahead of all phones on the line.

POWER TRANSFORMER PART NO. 22-035
CANADA CSA PART NO. 22-064

OVERVIEW

The transformer is a 9 volt AC, 15VA plug in style. The Control Panel converts the 9 volts AC to a DC voltage for operation and supplies a charging voltage to the back-up battery if that option is being used.

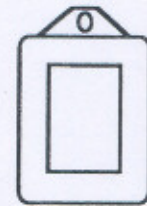

PRELIMINARY CONSIDERATIONS

- Locate the transformer where an intruder cannot detect its presence.
- Use 2 conductor, 22 gauge or greater stranded wire from the Control Panel to the transformer.
- Use only an AC outlet that is not controlled by a switch.

INSTALLATION

1. Run your cable from the Control Panel to the transformer location.
2. Follow the diagram at right for proper connections.

Note: Do Not power up the Control Panel at this time. The following procedure includes a check of your work and precautions you should take prior to power up.

CAUTION! DO NOT substitute a higher voltage transformer or permanent damage to the control panel will result. Use only the 9VAC transformer included with the Control Panel control panel.

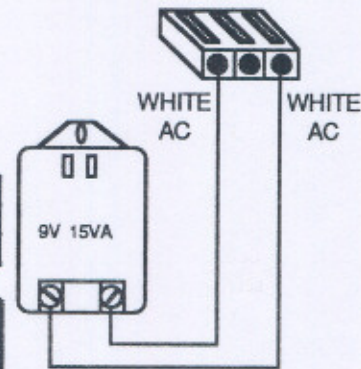

POWER UP

CONTROL PANEL CONNECTIONS

1. All splices to the wire harnesses should be made with insulated crimp connectors.
2. Instead of cutting unused wires, install a crimp connector on them. You may need to use these wires in the future if your customer decides to add a feature to their system.
3. Follow the diagram on page 15 and connect the wire harnesses accordingly.
4. Remove the 9 volt battery from the back of the panel and re-install it with the terminals facing up toward the top of the panel.
5. Connect the battery clip to the battery.
6. Place the Control Panel on its mounting plate on the wall and secure it by inserting the *tamper screw* all the way in.

At this time, the panel is ready for power up. Plug the transformer into the receptacle. The POWER and READY LEDs should be ON.





If the POWER and READY LEDs are not ON, unplug the transformer. Proceed to the Troubleshooting section of this manual (page 23).

To permanently mount the transformer first unplug it, then remove the existing screw from the AC outlet. Hold the outlet cover plate in place and plug the transformer back into the lower receptacle. Insert the screw, included with the transformer through the support tab at the top of the transformer and into the outlet screw hole. Gently tighten the screw.

PROGRAMMING

MEMORY CLEAR

Back the *tamper screw* out just until the LEDs begin flashing. The control panel is now in the *program mode*. Using the control panel touchpad, enter:

 +  +  +  The control panel will announce **"MEMORY GOODBYE."**

This command clears factory test programming and any erroneous data caused by shipping and handling.

PROGRAM MODE FEATURES

The following features can now be programmed into the control panel memory. The control panel will verify the programming of each feature by announcing the VALUE entry and **"OKAY."**

FEATURE

PRESS

VALUE

HOUSE CODE: The House Code is the system's unique identification number which allows communications between the control panel and the sensors. When programming House Codes 1-9, your entry must include "00" first. For House Codes 10-99 your entry must include a "0" first.

 +  + **001-254**

To double check your programming enter:  +  and wait for the voice message **"nnn OKAY."**



DURESS CODE: The Duress Code is a special four digit code which allows the customer to send a silent alarm to the Central Station. The first two digits of the Duress Code are the same as the regular access code, the last two digits are different. For example, if the regular access code is 1 2 3 4 and you program "06" using the procedure at left, the Duress Code would be 1 2 0 6.

 +  + **00-99**

To double check your programming enter:  +  and wait for the voice message **"nn OKAY."**

SIREN TIMEOUT: The Siren Timeout feature allows you to set from 1-9 minutes, how long the sirens will sound during an *alarm* condition if there is no one present to disarm the system immediately. A "0" is *not* necessary when programming this feature. (Minimum 4 minutes for U.L. installations.)

 +  + **2-9**



To double check your programming enter:  +  and wait for the voice message **"n OKAY."**



FEATURE

PRESS



VALUE



ENTRY DELAY: The Entry Delay feature allows the customer enough time to disarm the system before it goes into alarm, after entering the premises. VALUE entries should be in intervals of 8. Any other entries will be rounded down to the nearest division of 8. For example, if you enter a VALUE of 30, the control panel will announce **"TWO FOUR OKAY"**. (Maximum 45 seconds for U.L. installations.)

 +  + **STATUS** + **8-88 Seconds**

To double check your programming enter:  +  + STATUS and wait for the voice message **"nn OKAY."**

EXIT DELAY: The Exit Delay feature allows the customer enough time to leave the premises after arming the system. Follow the same VALUE guidelines as described above for the Entry Delay. (Maximum 60 seconds for U.L. installations.)

 +  + **BYPASS** + **8-88 Seconds**

To double check your programming enter:  +  + BYPASS and wait for the voice message **"nn OKAY."**

FEATURE

PRESS

VALUE

ACCOUNT NUMBER: The Account Number is the Central Station's identification number of your customer's system. Only *numbers* can be entered when programming from the control panel touchpad.



If you need alphabetical characters in the Account Number, you must contact the Central Station on the phone and perform a Phone Test (CODE + 8).

C.S. PHONE NUMBER This feature allows the control panel to dial the phone number of the Central Station CS-4000 receiver and report *alarm* and *trouble* conditions. If you need a *pause* between digits, such as to gain access to an outside line, press the FIRE button two times. Each pause counts as a digit.

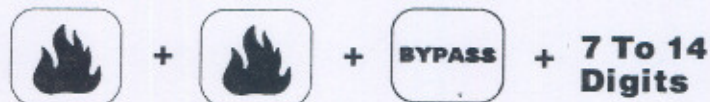

EXAMPLE: 9 + 18001234567

SENSOR NUMBERS

The maximum amount of sensor numbers from 00-16 that can be programmed is 17. Any attempt to program a sensor number from 17-79 will cause the control panel to announce "INVALID, TRY AGAIN." When initializing sensor numbers 0-9, your entry must include a "0" first. Listen for the voice message "SENSOR nn OKAY" when initializing sensors.

FEATURE

PRESS

VALUE

INITIALIZE SENSORS

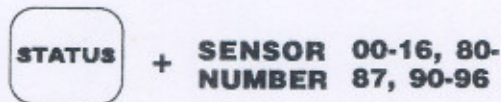

To review, press the STATUS button and the Control Panel will announce each programmed sensor number as "SENSOR nn ON."

DELETE SENSORS

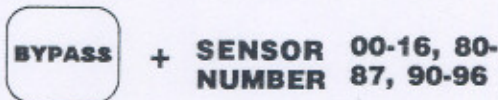

When deleting sensor numbers 0-9, your entry must include a "0" first. Listen for the voice message "SENSOR nn GOODBYE" when deleting sensor numbers.

Sensor # Function

00	Auxiliary (Freeze Sensor)
01-03	Fire/Heat Sensors
04-05	Time Delay Doors
06-10	Exterior Instant
11-13	Interior Instant PIR/Sound
14	Audible Police Panic (Unsupervised)
15	Silent Police Panic
16	Audible Auxiliary Panic (Unsupervised)
80	Touchpad Fire Panic
81	Touchpad Police Panic
82	Touchpad Auxiliary Panic
83	Phone Test (Level 8)
84	Opening Report (Optional*)
85	Closing Report (Optional*)

Sensor # Function

86	Duress Alarm Report
87	Force Armed Auto
87	Force Armed (Optional*)
90	AC Failure (Optional*-see note 2.)
91	Low CPU Battery (See note 2.)
92	CPU Tamper (See note 3.)
93	Auto. Phone Test (Optional*-see note 2.)
94	Receiver Failure (See note 3.)
94	Invalid Sensor Number
95	CPU Back In Service
96	Fail To Communicate (See note 2.)

* See page 15 for descriptions of Optional Features.

NOTE 1: Sensor numbers 80-83, 86-87, 91-92, and 94-96 are pre-programmed (factory set ON). Although these numbers may be deleted, it is recommended *not* to do so.

NOTE 2: In U.L. Listed applications which employ either the model 60-135 or 60-151 Door/Window sensors, the digital alarm communicator shall be employed. The following sensor numbers then, shall be enabled: 90-AC Failure, 91-Low CPU Battery, 93-Auto. Phone Test (1 day) and 96-Failure To Communicate.

NOTE 3: In all U.L. applications, sensor numbers 92-CPU Tamper and 94-Receiver Failure shall be enabled.

OPTIONAL FEATURES**84 OPENING REPORT USER #1-6**

When programmed, this report to the Central Station indicates the user has disarmed the system.

85 CLOSING REPORT USER #1-6

When programmed, this report to the Central Station indicates the user has armed the system.

87 FORCE ARMED

When programmed, this report to the Central Station indicates the customer *bypassed* a sensor which protested upon the arming attempt.

90 AC FAILURE

When programmed, this report to the Central Station indicates the control panel has been without AC power for 15 minutes.

93 AUTOMATIC PHONE TEST

When programmed, this report is sent to the Central Station every 35 days. The interval can be set from 1 to 255 days, only from the CS-4000 Central Station Receiver.

PRE-PROGRAMMED FEATURES

87 FORCE ARMED AUTO: The Control Panel sends this report to the Central Station indicating it automatically *armed* and *bypassed* a sensor after the user armed the system and did not bypass the protesting sensor.

NOTE: This report *is not* the same as the one described under Optional Features. This report is possible under the circumstances just described whether or not 87 is programmed.

91 LOW CPU BATTERY: When the back-up battery drops to 6.5 volts, the control panel will send this signal to the Central Station.

92 ALARM! TAMPER: Indicates someone has loosened and/or removed the tamper screw from the control panel while the system was armed to level 2 or 3.

94 RECEIVER FAILURE: The control panel has not received supervisory signals from any sensors for 2 hours, indicating the receiver has stopped working.

94 INVALID SENSOR NUMBER: Indicates another ITI System in range, operating on the same House Code. See Troubleshooting page 23.

95 CPU BACK IN SERVICE: The control panel sends this signal to the Central Station after AC power has been restored, bringing the panel out of the "sleep" mode. The control panel goes into the "sleep" mode after 4 hours and 15 minutes without AC power. When AC power is restored the panel automatically re-arms to the previous level of protection prior to going to "sleep".

96 FAIL TO COMMUNICATE: Notifies the customer on premises only that the control panel was not able to communicate with the Central Station.

NORMAL MODE PROGRAMMING

Turn the *tamper screw* back into the panel and the LEDs should stop flashing. The control panel is now in the *normal* operation mode and will allow you to program the options described below.

PRIMARY ACCESS CODE: The Primary Access Code is the customer's personal key to operating the Control Panel. The code defaults at power-up to **1 2 3 4**. To change the code, enter the current Primary Access Code with the procedure below.

1 2 3 4 + 5 + NEW CODE (4 digits).

The control panel will announce the new code and **"OKAY"** to confirm the programming.

VISITOR ACCESS CODE: This 4 digit code can be programmed for use by a baby-sitter, serviceperson or anyone else the customer decides to allow entry to when they are not on the premises. To set the code enter:

PRIMARY CODE + 6 + VISITOR CODE

The control panel will announce the Visitor Code and **"OKAY"** to confirm the programming.

NOTE: This code allows the user to perform all commands except for changing Primary/Visitor Access Codes.

OPTIONAL CS-4000 PROGRAMMING

This programming method shall not be used in U.L. Listed applications.

The options described below can only be programmed from the CS-4000 Central Station Receiver. A complete list of all CS-4000 programming commands are described on the following page.

MULTIPLE USER CODES: The Control Panel allows up to 4 additional user codes to be programmed from the CS-4000 Central Station Receiver.

Multiple User Codes are desirable for systems programmed with Opening/Closing reports because the user number is also included in the report. The Primary Access Code reports as *User # 1*. The Visitor Access Code reports as *User # 2*. This means the next code the Central Station operator programs will be *User # 3*. Be sure to have your customer specify which User # they want assigned to each code. These codes can only be programmed from the CS-4000 Central Station Receiver using the procedure below.

1. Call the Central Station with the codes the customer has asked to be programmed into the control panel.
2. Give the Central Station operator the Account Number of the system so they can set a "trap" on their CS-4000 Receiver.
3. Hang-up the phone and check to be sure the special DB-8 Cord is plugged into the RJ-31X jack. Send a Phone Test to the Central Station by entering **PRIMARY CODE + 8**. The control panel will announce **"PHONE TEST IS ON."**
4. After the Central Station operator has completed programming all User Codes the control panel should announce **"PHONE TEST IS OKAY."**
5. Enter each User Code + Protection Level 1, 2 or 3. The control panel should announce the chosen level of protection if programming is correct.
6. Contact your Central Station operator if any codes don't work properly.

SECONDARY PHONE NUMBER: This option allows the control panel to dial a second phone number (up to 8 attempts) in the event it could not make contact to the Central Station after 3 dialing attempts by the primary C.S. Phone Number (see page 14). This feature can only be programmed from the CS-4000 Central Station Receiver using the procedure below.

1. Call the Central Station and give the operator the Account Number of the system you are working on so they can set a "trap" for it on their CS-4000 Receiver.
2. Inform the operator you want them to program the option PHONE 2 (see CS-4000 Programming, page 17).
3. Hang-up the phone and check to be sure the special DB-8 Cord is plugged into the RJ-31X jack. Send a Phone Test to the Central Station by entering **PRIMARY CODE + 8**. The control panel will announce **"PHONE TEST IS ON."**
4. After the Central Station operator has completed programming the Secondary Phone Number the control panel should announce **"PHONE TEST IS OKAY."**

CS-4000 PROGRAMMING

All Control Panel features are programmable from the ITI CS-4000 Central Station Receiver. The following list describes the commands required for Central Station programming.

FEATURE	COMMAND	VALUE	DEFAULT
House Code	HOUSE NNN	001-254	000
Primary Access Code	ACCESS NNN	Any 4 digits	1 2 3 4
Visitor Access Code	MACCESS 2 NNNN	Any 4 digits	None
Multiple User Codes 3-6	MACCESS N NNNN	N = user # 3-6 NNNN = 4 digit code.	None
Duress Code	DURESS NN	Any 2 digits	None
Entrance Delay	ENTRANCE NN	8-88 seconds	32 seconds
Exit Delay	EXIT NN	8-88 seconds	32 seconds
Siren Timeout	SIREN N	2-9 minutes	4 minutes
Account Number	ACCT NN-NNN	Any 5 digits, letters or combination of both.	00-000
C.S. Phone Number	PHONE NNNNNNN	7 to 14 digits including pauses. Enter D for pause.	None
Secondary Phone Number	PHO2 NNNNNNN	Same as above.	None
Initialize Sensors	INITIALIZE NN	NN = 00-16, 80-87, 90-96.	80-83, 86, 91-92, 94-96
Delete Sensors	DELETE NN	Same as above.	None
Bypass Sensors	BYPASS NN	NN = 00, 04-16	None
Supervisory Report Time	STIME	hh:mm (24 Hr. Clock)	00:00
Protection Level Change*	PLEVEL N	N = 1-7	None
Automatic Phone Test Freq.**	PTFREQ N	N = 1-255 days.	35 days
Zone Dump	ZONES		

* **WARNING!** The Protection Level shall not be remotely changed in U.L. Listed applications.

** In U.L. Listed applications, this action shall be programmed for 1 day.

CENTRAL STATION REPORTS

00 ALARM!	Auxiliary Alarm (Freeze Sensor)	80 ALARM!	Touchpad Fire
01 ALARM!	Fire Sensor	81 ALARM!	Touchpad Police
02 ALARM!	Fire Sensor	82 ALARM!	Touchpad Emergency
03 ALARM!	Fire Sensor	83 ALARM!	Phone Test
04 ALARM!	Perimeter Delay	84 ALARM!	Opening Report
05 ALARM!	Perimeter Delay	85 ALARM!	Closing Report
06 ALARM!	Instant Perimeter	86 ALARM!	Silent Duress
07 ALARM!	Instant Perimeter	87 ALARM!	Force Armed Auto/Force Armed
08 ALARM!	Instant Perimeter	90 ALARM!	AC Failure
09 ALARM!	Instant Perimeter	91 ALARM!	Low CPU Battery
10 ALARM!	Instant Perimeter	92 ALARM!	CPU Tamper
11 ALARM!	Instant Interior	93 ALARM!	Automatic Phone Test
12 ALARM!	Instant Interior	94 ALARM!	Receiver Fail/Invalid Sensor
13 ALARM!	Instant Interior	95 ALARM!	CPU Back In Service
14 ALARM!	Audible Police Panic †		
15 ALARM!	Silent Police Panic		
16 ALARM!	Audible Medical Panic †		

† Unsupervised

WIRELESS SENSORS

CAUTION



You must be free of static electricity before handling and installing any sensor. Discharge yourself of static electricity by first touching a metallic surface. Door/Window and Shock sensor circuit boards should be handled only by the battery holder or the edges of the board. Once the board is removed from the base, place it in the sensor cover until you have mounted the base and are ready to re-install the board onto the base.

MOUNTING

Follow the instructions included with each sensor. When mounting Door/Window and Shock sensor bases, be sure to use screws with heads that won't make contact with the bottom side of the sensor's circuit board. Do not program any sensors until all handling and mounting has been completed.

PROGRAMMING

The Control Panel allows a maximum of 17 protection sensors to be used. The list below describes the available sensor numbers and their function. Programming sensors requires use of the Handheld Programmer (part no. 60-371). When entering sensor numbers 00-09, the programmer requires only the single digit form of the number. Read the instructions on the back of the programmer for complete sensor programming information.

Sensor Number	Sensor Type	Sensor Function
00	0	Auxiliary (Freeze Sensor)
01-03	8/9	Smoke/Heat Sensors
04-05	1	Time Delay Doors
06-10	1	Perimeter Instant
11-13	2	Interior Instant PIR/Sound
14	7	Audible Police Panic (Unsupervised)
15	6	Silent Police Panic
16	7	Audible Auxiliary Panic (Unsupervised)

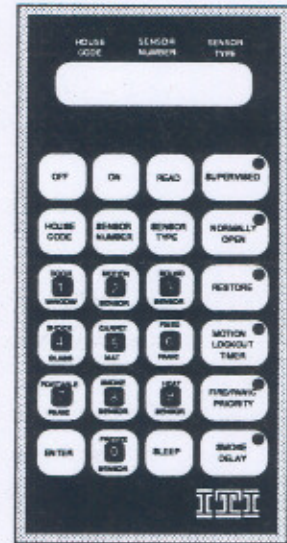

WIRELESS TOUCHPADS

Follow the programming instructions included with the touchpad. If a touchpad fails to program, proceed to the troubleshooting section of this manual (page 23).

* The model 60-389 can be used in U.L. Listed applications.

ITI Part No. 60-389*

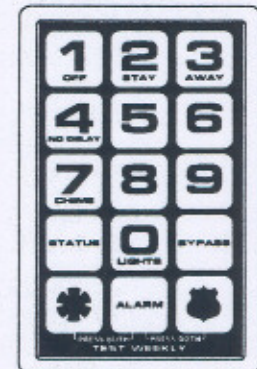

TESTING

LED DISPLAY

Before you begin testing the configuration of your installation it's important to understand how the Control Panel LED Display responds to all system status conditions.

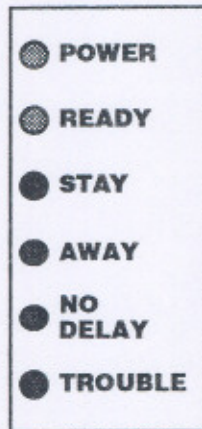

POWER (Green)

ON - AC power ON, back-up battery good.
OFF - AC power OFF, back-up battery good.
FLASHING - AC power ON, back-up battery bad.

READY (Green)

ON - Perimeter and Interior sensors ready to arm.
OFF - Perimeter and Interior sensors are open.
FLASHING - Perimeter sensors only are ready to arm.

STAY (Red)

ON - System is armed to Level 2, perimeter protection only.
FLASHING - System is armed to Level 2 with sensor(s) bypassed.

AWAY (Red)

ON - System armed to Level 3, full protection.
FLASHING - System armed to Level 3 with sensor(s) bypassed.

NO DELAY (Red)

ON - Delays are not active.
OFF - Delays are active (normal).

TROUBLE (Red)

OFF - Normal operation.
FLASHING - When something is not operating properly. Press STATUS button for voice announcement of problem.

Note: The TROUBLE and POWER LEDs will both flash when the Back-Up Battery is bad.

Close all doors and windows on the premise which are protected by a sensor. The READY LED should be ON. If the READY LED is FLASHING, an interior sensor, such as an Interior Door has not reset. Close the door and return to the Control Panel. The READY LED should now be ON.

PROTECTION LEVELS

Level 1: All 24 hour sensors such as Smoke/Heat Detectors, Touchpad and Portable/Pendant Panics are active.

Level 2: All 24 hour sensors and Perimeter sensors (04-10) are active. Interior sensors (11-13) are off.

Level 3: All 24 hour, Interior and Perimeter sensors are active.

ARM/DISARM THE SYSTEM

Using the Built-In Touchpad

Enter: CODE + 2.

Listen for: 2 beeps and "ALARM SYSTEM IS ON LEVEL TWO."

Enter: CODE + 1.

Listen for: 1 long beep and "ALARM SYSTEM IS OFF."

Enter: CODE + 3.

Listen for: 3 beeps and "ALARM SYSTEM IS ON LEVEL THREE."

Enter: CODE + 1.

Listen for: 1 long beep and "ALARM SYSTEM IS OFF."

Using a Wireless Touchpad

Enter: CODE + 2.

Listen for: 2 beeps from the interior sirens and control panel speaker.

Enter: CODE + 1.

Listen for: 1 long beep from the interior sirens and control panel speaker.

Enter: CODE + 3.

Listen for: 3 beeps from the interior sirens and control panel speaker.

Enter: CODE + 1.

Listen for: 1 long beep from the interior sirens and control panel speaker.

SENSOR TEST

The Sensor Test (Level 9) is used to verify the radio signal strength from the sensors to the control panel. Level 9 also tests the back-up battery by switching over to battery power for the entire test.

Central Station communication of any alarm condition is not possible in Level 9 unless the Duress Code is used. Therefore, the control panel will stay in Level 9 for 15 minutes and then automatically go to Level 1, or you can manually change to Level 1 after you have tested all sensors.

Should you find that 15 minutes is not enough time to test all the sensors in the system, re-entering Level 9 (without going to any other level) will reset the 15 minute timer. This feature permits you to test all untested sensors without having to re-test the others.

Enter: PRIMARY ACCESS CODE + 9

Listen for: 1 long beep and "SENSOR TEST IS ON."

As you trip each sensor listen for the Interior Sirens and the the control panel speaker to emit a series of beeps. This indicates the signal strength from that particular sensor. After the beeps have stopped the control panel will announce "SENSOR nn OKAY." To determine if the signal strength of a sensor is acceptable, see the charts below.

Burglary Type Protection Sensors (Door/Window, Shock, PIR, & Sound Sensors)

6-8 Beeps	Good
5 or less	Poor

Life Safety Type Sensors (Smoke/Heat Sensors, Portable & Touchpad Panics)

12-16 Beeps	Good
11 or less	Poor

SMOKE SENSORS: Press and hold the test button on each Smoke Sensor until the unit's built-in piezo activates. This indicates that the sensor's transmitter has been activated.

PIR SENSORS: These sensors have a Lock-Out Timer which prohibits the PIR from transmitting more than once in 3 minutes. This feature is built-in to all PIRs to conserve on the sensor's batteries. If the control panel does not respond when you walk through the path of a PIR, clear all occupants from the room for 3 minutes and then re-test the sensor.

SENSORS with TAMPER BUTTONS: All Door/Window, Shock, Glass Guard and Freeze Sensors have a built-in tamper button which activates when the sensor cover is removed. During a Sensor Test, tripping a Tamper Button will cause all Interior Sirens and the control panel speaker to emit 4 beeps. *This is not a valid signal strength test!* Sensors must be tripped with sensor covers ON.

WIRELESS TOUCHPADS/PANICS: Test all Wireless Touchpads and Panic Buttons from several locations on the premises.

TROUBLESHOOTING

Any sensors which test in the Poor range may need to be re-located. Before doing so, experiment with the sensor by rotating it 90° to 180°. For example, if a Door/Window Sensor is mounted vertically (a), rotate it 90° to a horizontal position (b). Test the sensor again and if there is no improvement, rotate the sensor another 90°(c) so that it is now in the opposite vertical position it was at originally.

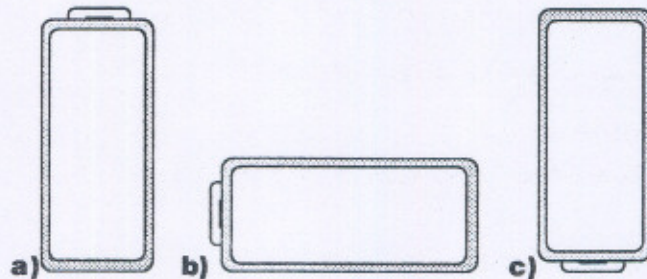

Changing a sensor's position by rotating it also changes the position of the transmitter's antenna. In most cases of poor range, this procedure should be all that is required to improve the signal strength.

In cases where sensor rotation does not improve the signal strength, re-location is necessary. Before mounting the sensor in a new location, perform a signal strength test from various points nearest to where the sensor was first mounted. Sometimes only a short distance move is required.

Before assuming you have a defective sensor, take another sensor that is working properly to the same location and trip it several times. If the signal strength is still poor, that area of the premises should be avoided for sensor mounting. If the signal strength is good, contact ITI Tech Services at 1-800-777-2624 for possible sensor replacement.

SYSTEM TEST

Once the Sensor Test is completed the system should be tested by arming and tripping each sensor to ensure it creates the proper alarm condition. Communication to the Central Station should also be confirmed at this time. Perform the following procedures from the built-in touchpad.

LEVEL 3

1. Check to be sure the DB-8 cord is plugged into the RJ-31X jack.
2. Call the Central Station to inform the operator you will be testing system NN-NNN (Account Number) and that they *should not dispatch any authorities*. Hang-up the phone.
3. Close all Exterior and Interior sensors (READY LED on).
4. **Enter:** ACCESS CODE + 3. Listen for 3 beeps and "**ALARM SYSTEM IS ON LEVEL THREE.**"
5. The AWAY LED should be ON.
6. Trip one sensor and allow the panel time to report to the Central Station. The LEDs on the Control Panel should be scrolling to indicate there is an alarm in memory.
7. Check all sirens to be sure they are activated.
8. **Enter:** ACCESS CODE + 1. Sirens should stop immediately. The Control Panel will announce the sensor number and type that was tripped, then emit 1 long beep and announce that the system is off. For example: "**SENSOR ONE ZERO INTRUSION, ALARM MEMORY**" Listen for 1 long beep and "**ALARM SYSTEM IS OFF.**"

It is recommended that each sensor be tested using the procedure above to ensure proper operation and communication to the Central Station.

LEVEL 2

1. **Enter:** ACCESS CODE + 2. Listen for 2 beeps and "**ALARM SYSTEM IS ON LEVEL TWO.**"
2. The STAY LED should be ON.
3. Trip each Interior sensor (11-13) to be sure they *don't* cause an alarm condition.
4. **Enter:** ACCESS CODE + 1. Listen for 1 long beep and "**ALARM SYSTEM IS OFF.**"

NO DELAY (4)

After arming the system to Level 2 or 3, selecting 4 will eliminate the *entry and exit time delays* on sensors 04-05. These sensors will immediately go into alarm if they are tripped.

1. **Enter:** ACCESS CODE + 2. Listen for "**ALARM SYSTEM IS ON LEVEL TWO.**"
2. **Enter:** 4 and listen for "**NO DELAY.**"
3. Trip either sensor 04 or 05. The panel should immediately go into alarm.
4. **Enter:** ACCESS CODE + 1. Sirens should stop immediately. The Control Panel will announce the sensor number and type that was tripped, then emit 1 long beep and announce that the system is off. For example: "**SENSOR ZERO FOUR INTRUSION, ALARM MEMORY.**" Listen for 1 long beep and "**ALARM SYSTEM IS OFF.**"

DIRECT BYPASSING

Follow the procedure below to bypass a sensor after successful arming of the system. Sensor 06 will be used as an example.

1. Close all Exterior and Interior sensors (READY LED on).
2. **Enter:** ACCESS CODE + 3. Listen for: 3 beeps and "**ALARM SYSTEM IS ON LEVEL THREE.**"
3. **Enter:** ACCESS CODE + BYPASS + 06. Listen for "**SENSOR ZERO SIX BYPASSED.**"
4. The AWAY LED should be flashing to indicate the system is armed to Level 3 with a sensor bypassed.
5. Trip sensor 06. No alarm condition should occur.
6. **Enter:** ACCESS CODE + 1. Listen for "**ALARM SYSTEM IS OFF.**"

INDIRECT BYPASSING (For U.L. Listed systems, this bypassing method shall not be shown to the user.)

Follow the procedure below to bypass an open sensor which protests upon arming. Sensor 06 will be used as an example.

1. Open sensor 06.
2. **Enter:** ACCESS CODE + 2. Listen for "**SENSOR SIX OPEN**" followed by protest beeps.
3. Press BYPASS. Listen for 2 beeps and "**ALARM SYSTEM IS ON LEVEL TWO, SENSOR SIX BYPASSED.**"
4. The STAY LED should be flashing to indicate the system is armed to Level 2 with a sensor bypassed.
5. **Enter:** ACCESS CODE + 1. Listen for 1 long beep and "**ALARM SYSTEM IS OFF.**"



FIRE PANIC

1. Press twice within 3 seconds or press and hold for 3 seconds. All Interior sirens and the control panel speaker should activate. The LEDs on the Control Panel should be scrolling to indicate there is an alarm in memory.
 2. **Enter:** ACCESS CODE + 1. Sirens should stop immediately. The Control Panel will announce **"SENSOR EIGHT ZERO FIRE, ALARM MEMORY."** Listen for 1 long beep and **"ALARM SYSTEM IS OFF."**
-



POLICE PANIC

1. Press twice within 3 seconds or press and hold for 3 seconds. All Interior sirens and the control panel speaker should activate. The LEDs on the Control Panel should be scrolling to indicate there is an alarm in memory.
 2. **Enter:** ACCESS CODE + 1. Sirens should stop immediately. The Control Panel will announce **"SENSOR EIGHT ONE INTRUSION, ALARM MEMORY."** Listen for 1 long beep and **"ALARM SYSTEM IS OFF."**
-



AUXILIARY PANIC

1. Press twice within 3 seconds or press and hold for 3 seconds. All Interior sirens and the control panel speaker should activate. The LEDs on the Control Panel should be scrolling to indicate there is an alarm in memory.
 2. **Enter:** ACCESS CODE + 1. Sirens should stop immediately. The Control Panel will announce **"SENSOR EIGHT ZERO FIRE, ALARM MEMORY."** Listen for 1 long beep and **"ALARM SYSTEM IS OFF."**
-

CHIME (7) (System must be in Level 1)

1. **Enter:** CODE + 7. Listen for **"ON."**
 2. Trip each Exterior sensor (04-10). Listen for Interior sirens and control panel speaker to emit 1 beep for each trip.
 3. **Enter:** CODE + 7. Listen for **"OFF."**
-

WIRELESS TOUCHPADS

Test all Wireless Touchpads from several locations on the premises using the procedures above and on page 21. The control panel will respond the same except it will not emit any voice messages. You must rely on the number of beeps generated from all Interior sirens and the control panel speaker after entering commands from a Wireless Touchpad.

TROUBLESHOOTING

SENSORS

PROBLEM: Sensor doesn't respond in Sensor Test or System Test.

ACTION:

- Check control panel memory for that sensor number.
- Check sensor for incorrect or no programming information (SLEEP).

PROBLEM: Sensor won't program (FAIL).

ACTION:

- Check polarity of programming cable.
- Make sure battery is connected to sensor.
- Check for low battery in sensor.
- Check for low battery in programmer.

WIRELESS TOUCHPADS

PROBLEM: Control Panel won't respond to commands from Wireless Touchpads.

ACTION:

- Try different locations on the premises.
- Check for incorrect House Code programming.
- Check for low battery in touchpad.

PROBLEM: Touchpad keys don't emit beeps when pressed.

ACTION:

- Check voltage of battery in touchpad. Replace if necessary and reprogram the touchpad.

SIRENS

PROBLEM: Interior sirens don't emit any sound.

ACTION:

- If this problem involves Phone Jack Sirens connected with existing phone cable, check to be sure that the two wires you are using from the cable are not cut at *any* phone jack location. Splice these wires back together where necessary.
- Check for proper wiring polarity at all sirens and the control panel.

PROBLEM: Interior sirens emit Alarm sounds but no Status sounds.

ACTION:

- Interior sirens may be hooked-up to Exterior siren line (Blue). Connect to Orange line and re-test sirens.

PROBLEM: Exterior siren is emitting Status sounds.

ACTION:

- Exterior siren may be hooked-up to Interior siren line (Orange). Connect to Blue line and re-test siren.

COMMUNICATION

PROBLEM: Central Station is not receiving any reports.

ACTION:

- Make sure DB-8 cord is connected to RJ-31X.
- Check to be sure the C.S. phone number is programmed.
- Call the Central Station operator and confirm the phone number of the receiver line. Re-program the C.S. phone number if necessary and re-test.
- Check for improper wiring of the RJ 31X (see page 11).

PHONES

PROBLEM: Can't dial out on phones (constant dial tone).

ACTION:

- This indicates there are polarity sensitive phones on the premises. Reverse the wires you connected to the Brown and Gray wires on the RJ-31X Jack.

CONTROL PANEL

PROBLEM: Unit won't power-up.

ACTION:

- Check to see if transformer fell out of outlet. Secure the transformer to the outlet with the screw provided.
- Check for proper wiring at the control panel.
- Use a voltmeter to check the incoming voltage at the panel. The meter should read 9 volts AC.
- If the meter reads 0 volts AC disconnect the transformer wire at the control panel and the transformer. Check for continuity (short) between the two conductors or an open on either conductor.

PROBLEM: Unit powers up with all LEDs ON.

ACTION:

This indicates a CheckSum (Memory) Error. Back the tamper screw out until all the LEDs begin flashing. Turn the tamper screw back into the panel. The POWER and READY LEDs should be ON.

PROBLEM: Panel reports "94 Invalid Sensor Number" to Central Station.

ACTION:

- This report indicates there is another ITI security system in range of the Control Panel on the same House Code. You must change the House Code of the Control Panel to eliminate the problem. See page 13.

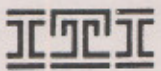

Interactive Technologies, Inc.
2266 North Second Street
North St. Paul, MN 55109

© 1990 Interactive Technologies, Inc.

46-322

