

# ESL

## Electromagnetic Door Holder

### Assembly Instructions & Electric Configurations

Part Number 13047



California State Fire Marshal Approved  
MEA (New York City)

## II. Electromagnet Mounting

### Surface Mounting

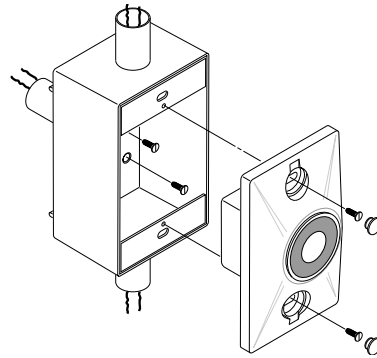

### Flush Mounting

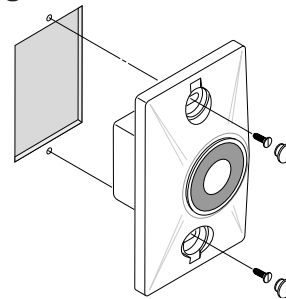

### Recessed Mounting

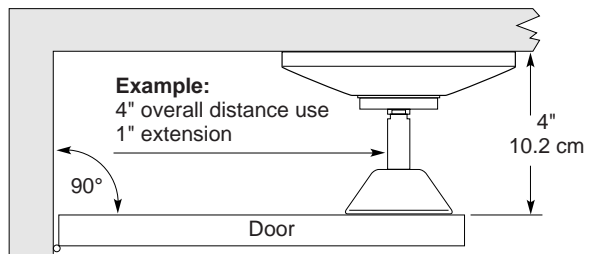
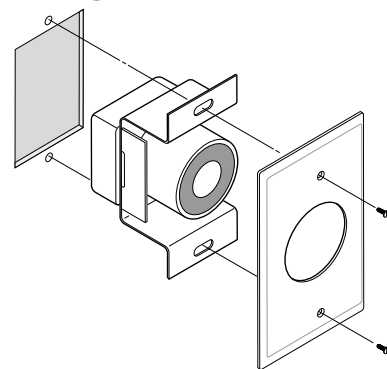

This product is a high quality electromagnetic holding device intended for use in fire door applications.

## I. Wiring Instructions

### Voltage References

C= common  
L= low  
H= high

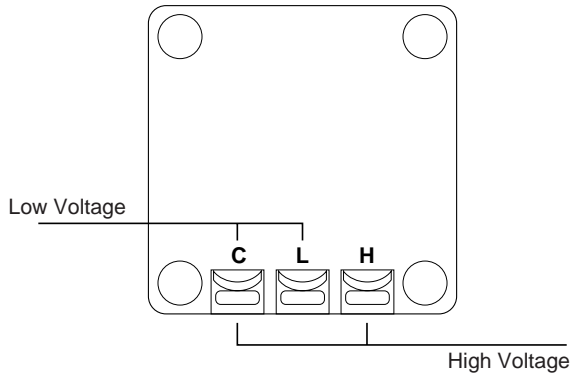

### Low Voltage Application

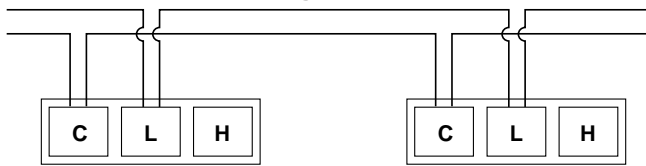

### High Voltage Application

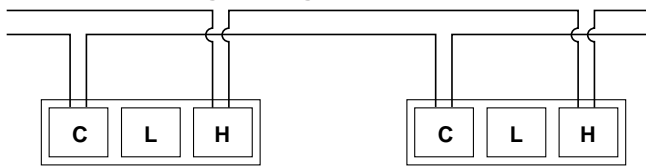

### Performance Data

Model	Voltage	DC	AC	Terminals
DHX*-1224	12V	30mA	30mA	C and L
	24V	30mA	30mA	C and H
DHX*-24120	24V	15mA	15mA	C and L
	120V	—	15mA	C and H
DHX*-24220	24V	15mA	15mA	C and L
	220V	—	15mA	C and H

\* X= F— Flush Mount  
R— Recessed Mount  
S— Surface Mount

**Note:**  
When using models DHX-24120 or DHX-24220 (see chart above) attach green wire to earth ground.

# Electromagnetic Door Holder

## Door Holder Assembly Instructions

### III. Catch-Plate Mounting

**Step 1:**  
With door magnet securely fastened, aligned and energized, proceed with swivel base assembly. NOTE: If door extensions are required, install before step 2.

**Step 2:**  
Attach swivel portion of magnet, being careful to center catch plate over magnet.

**Step 3:**  
With catch plate assembly attached magnetically to door magnet, peel adhesive backing off mounting template and slide over catch plate, making sure adhesive side faces door.

**Step 4:**  
Gently close door and with one hand adjust base of catch plate to lie flat against door.

**Step 5:**  
While keeping slight pressure on door, slide mounting template over catch plate to door surface and apply pressure to template in a few spots.

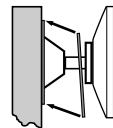
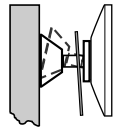
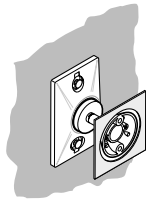
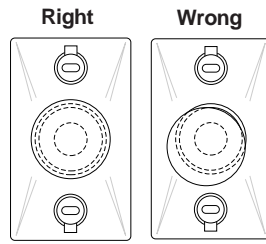

**Step 6:**  
Opening door will reveal mounting template. Apply final pressure to insure template does not fall off while assembly takes place.

**Step 7:**  
Insert alignment template into center of mounting template. Use tab to rotate for fine adjustment. While holding alignment template with one hand, remove adhesive backing of tab, then push flat against door.

**Step 8A:**  
If using optional door back plate, center punch points indicated on alignment template for either horizontal or vertical mounting. For best results drill 1/8" pilot first, then follow with 5/16" dia. drill.

**Step 8B:**  
If mounting catch plate assembly directly to door, drill 1/8" dia. pilot hole approximately 1 to 1 1/2" deep, being careful not to go through door.

**Step 9:**  
For either style of mounting (thru door/direct) remove only alignment template, then place swivel in center. Align holes, then insert screws and tighten assembly fully. Lastly, remove mounting template.

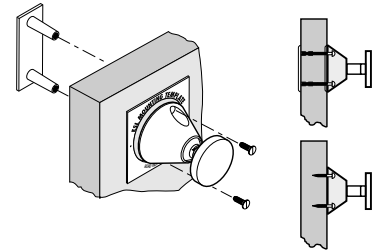
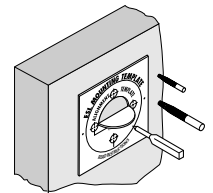
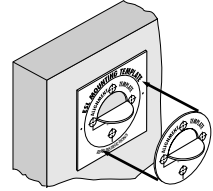
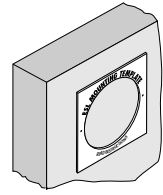

### IV. General Dimensions

#### Door Magnet Dimensions

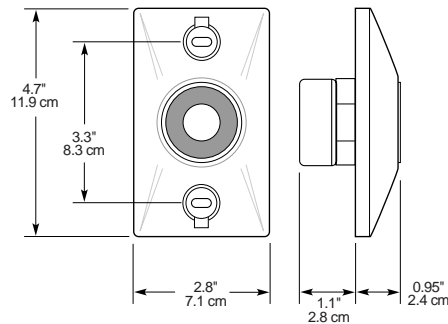

#### Surface Mount Back Box Dimensions

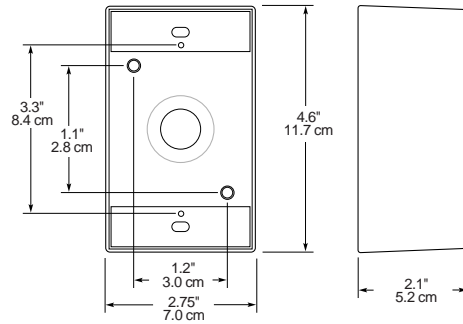

#### Catch Plate Dimensions

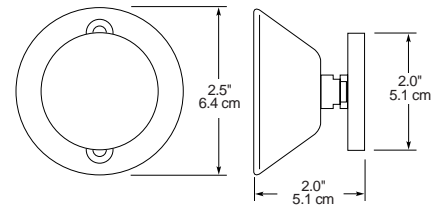

### V. Accessories

#### Extension Rods

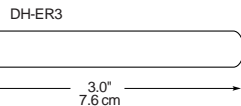
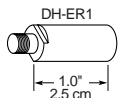

#### Backplate

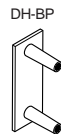

#### Catch Plate Extension Rod Assembly

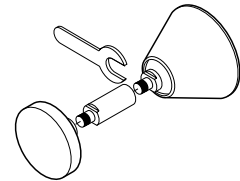

SENTROL

#### CORPORATE HEADQUARTERS

12345 SW Leveton Dr., Tualatin, OR 97062

Tel.: 503.692.4052 Fax: 503.691.7566

<http://www.sentrol.com>

U.S. & Canada: 800.547.2556

Technical Service: 800.648.7424

FaxBack: 800.483.2495

Sentrol reserves the right to change specifications without notice.

©1998 Sentrol

E-3627-1098  
13047 Rev. C