

Simon® Security System Installation Instructions

Document No. 466-1574

Rev F Dated February 2003

Table of Contents

Simon® Basic : 2

Special Installation Requirements 3

- Requirements for UL-Listed Installations 3
- Canada Listings (pending) 3
- California State Fire Marshall Listing 3
- Introduction 4
- System Components 4
- Planning Sensor Types & Locations 7
- Planning Control Locations 10
- Planning for Lamp*, Appliance*,
Wallswitch*, and Universal/Garage
Door* Module Control 10
- Setting the House Code and Unit Number 10
- Planning System Access Codes 12
 - Utility Access Code 1 12
 - Utility Access Code 2 12
 - Master Access Code 12
 - Access Codes (1 - 5) 12
 - Panic Code 12
- Planning System Options 12
 - Reset Memory to the Factory Defaults 20

Wiring the Control Panel 23

- Connecting Hardwire Interior Sirens 23
- Connecting a Hardwire Exterior Siren 23
- Connecting Hardwire Sensors 23
- Connecting the Universal/Garage Door
Opener Module* 24
- Connecting the Power Transformer 24
- Connecting the Backup Batteries 24
 - Installing a Non-rechargeable Battery 24
 - Installing a Rechargeable Battery 25
- Connecting the Phone Line to the Control
Panel 25
 - Installing an RJ-31X Jack 25
 - Connecting the Phone Line to the Control
Panel 25

Programming Overview 26

- Programming Sensors 27
- Programming the House Code and Unit
Numbers* 28
- Programming Light and Appliance Con-
trols* 28
- Programming Options 29
- Programming System Access Codes 30

Installing the System 31

- Control Panel General Information 31
- Control Panel Specifications 31
- Installation Guidelines 31
- Sensor Installation 32
- Testing the Control Panel 32

Testing the System 32

- Testing Sensors 33
 - Sensor Tripping Instructions: 33
 - If a Sensor Fails the Sensor Test 34
- Testing Phone Communication 34
- Testing Central Station Communication 34
- Testing the X-10 Lamp Modules* 35
- Siren and X-10 Lamp Module Functions*
35
- Panel Tamper 35
- Troubleshooting 36
- Typical Backup Battery Life of the 9 Volt Ul-
traLife 38

Notices 39

Index 41

Quick Reference Guide (Back Page)

Attachment: 466-1622, Booklet of Installa-
tion Instructions for SAW Sensors

Simon® Basic :

Features **not** Available with the Simon® Basic ITI # 60-776-02-95R

2-Way Voice
Remote Phone Control
Speaker Volume Control
Chime Special Motion
Light Control
Wireless Sirens

Options **not** for Use with Simon® Basic

Option 33: 2-Way Voice
Option 36: Sensor Activated Light Lockout Start
Time
Option 37: Sensor Activated Light Lockout Stop
Time
Option 42: Speaker Level
Option 46: Fire Shutdown - AVM
Option 47: AVM Mode
Option 48: Panic Talk

Modules that **Cannot** be Used with Simon® Basic

Interrogator 200 Audio Verification Module®
(AVM) (60-787)
X-10 Lamp (13-403)
Appliance (13-402)
Powerhorn/Remote (13-398)
Universal/Garage Door (13-399)
Wall Switch Modules (13-397)
Touchtalk 2-Way RF Touchpad (60-788-95R)
Supervised Wireless Siren SWS (60-736-95)



GE Interlogix

© 2003 GE Interlogix. Homelink, Interrogator, Simon and Toolbox are registered trademarks of GE Interlogix. All other trademarks are properties of their owners

All rights reserved

2266 Second Street North
North Saint Paul, MN 55109
Technical Support: 800-777-2624

Special Installation Requirements

This security system can be used as a fire warning system, an intrusion alarm system, an emergency notification system, or any combination of the three.

Some installations may require certain configurations dictated by city codes, state codes, or insurance requirements. The following information indicates the components of various listings.

Requirements for UL-Listed Installations

This section describes the minimum system configurations for UL-listed, Grade A (supervised) systems.

Typical System

All UL-listed systems require the following basic components. The basic system does not require sensors and can use the Remote Handheld Touchpad as a controlling device.

- Basic Control Panel (60-776-02-95R)
- Control Panel (60-776-95R)
- Control Panel On-Board 2-Way Voice (60-776-01-95R)*
- Class II Line Carrier Power Transformer (22-091)*
- 9-Volt, 1.2 Ah Lithium Backup Battery (34-037) or a rechargeable 7.2Volt, 1 Ah Nickel Metal Hydride Battery Pack (34-052)
- Hardwire Siren (13-046) or LD105 Siren (13-374)

Residential Burglary Alarm System Unit (UL 1023)

Basic system above, plus:

- Door/Window Sensor (60-670-95R) suitable for installation on non-ferrous surfaces only

Residential Fire Alarm System Unit (UL 985)

Basic system above, plus:

- System Sensor Smoke Sensor (60-506-95)

Canada Listings (pending)

Residential Burglary Alarm System Unit (ULC-S309)

Basic system as described for UL-listed installations, plus:

- Door/Window Sensor (60-670-95R)

Note: The KeyChain Touchpad #60-659 is UL Listed as a miscellaneous signalling device and is for supplementary use only.

CSA Certified Accessories

Residential Fire Warning System Control Unit (ULC-S545-M89)

Basic system as described for UL-listed installations, plus:

- Wireless Smoke Sensor (60-506-95)
- SUPSYNC (Supervisory Synchronization) set to 2 (hours)

California State Fire Marshall Listing

The California State Fire Marshall listing is approved.

Introduction

This ITI Security System is easy to install if you plan ahead and perform the installation in the following order.

1. Plan where to locate the hardwire sirens, sensors and Control Panel. Use the tear out planning sheets at back of this manual.
2. Wire the Class II transformer, hardwire sirens, and phone.
3. Decide how the sensors, lights, and system options will operate.
4. Program the sensors, lights and appliances, and system options.
5. Install sensors and Lighting Modules.
6. Test system.

Note: Program the sensors before installing them because the Control Panel and sensors must be in the same place for programming. After you've programmed each sensor, you can install them where you planned.

System Components

The system can monitor up to 24 sensors using any combination of the following sensors:

- Door/Window Sensor (60-670-95R)
- KeyChain Touchpad (60-659-95R)
- Remote Handheld Touchpad (60-671-95R)
- Touchtalk 2-Way RF Touchpad (60-788-95R)*
- Indoor Motion Sensor (60-639-95R)
- Outdoor Motion Sensor (60-639-95R-OD)
- Carbon Monoxide Alarm (60-652-95)
- Water Sensor (60-744-95R)
- Freeze Sensor (60-742-95R)
- SWS (60-736-95)*
- ITI 319.5 Sensors (including Smoke Sensors, excluding other touchpads)

Note: Both ITI SAW and Crystal sensors function with this Control Panel.

You may use any of these modules:

- Interrogator 200 Audio Verification Module (AVM) (60-787)*
- X-10 Lamp Modules (13-403)*
- X-10 Appliance Modules (13-402)*

- X-10 Powerhorn/Remote Siren Modules (13-398)*
- X-10 Universal/Garage Door Modules (13-399)*
- X-10 Wall Switch Modules (13-397)*

Note: Use of the above X-10 modules has not been investigated by UL.

Figure 1. shows the Control Panel, control touchpads, and some compatible sensors and modules.

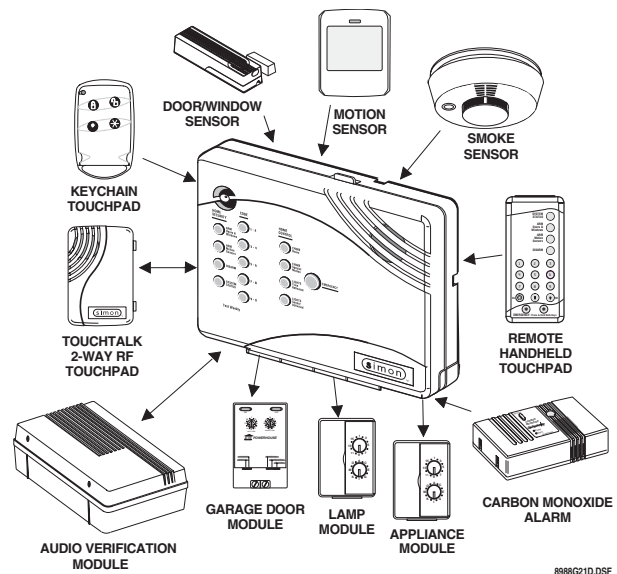

Figure 1. Typical Security System Components

Security System

The security system has three types of components: the Control Panel, devices that report to the Control Panel, and devices that respond to commands from the Control Panel.

Control Panel

The Control Panel is the main processing unit for all security functions. It receives signals from and responds to wireless sensors and wireless touchpads throughout the premises. The buttons operate the security system. When using the Control Panel with the cover open, the buttons program the security system.

Two configurations of the Simon Control Panel are available. One has an on-board 2-way voice microphone, the other does not. The Interrogator can be added to either configuration.

Door/Window Sensor

For intrusion protection, install Door/Window sensors on all ground-floor doors and windows. At a minimum, install them in the following locations:

- All easily accessible exterior doors and windows.
- Interior doors leading into the garage.
- Doors to areas containing valuables such as cabinets and closets.

KeyChain Touchpad

The KeyChain Touchpad enables you to turn the system on and off from right outside the home or to turn on the siren and to call the central monitoring station if there is an emergency. If you have Lamp Modules, you can use the KeyChain Touchpad to turn all system controlled lights on and off.

Remote Handheld Touchpad

The Remote Handheld Touchpad enables you to turn the system on and off while in the home, turn lights controlled by the system on and off (all or individual lights), or turn on a system siren and call the central monitoring station if there is a non-medical emergency. The Remote Handheld Touchpad will report an alarm type specific to its sensor type (see Table 3 on page 7 for sensor and siren types).

Touchtalk 2-Way RF Touchpad*

The wall-mounted wireless Touchtalk 2-Way RF Touchpad enables you to arm and disarm the system while in the home, turn system controlled lights on and off (all or individual lights), turn on a system siren, or call the central monitoring station if there is a non-medical emergency. The Touchtalk 2-Way RF Touchpad will report an alarm type specific to its sensor type (see Table 3 on page 7 for sensor and siren types). It annunciates status beeps and Control Panel voice feedback.

Note: Use of the Touchtalk 2-Way RF Touchpad has not been investigated by UL.

Indoor Motion Sensor

Indoor Motion Sensors are ideal whenever it is not practical to install Door/Window sensors on every opening. Identify areas where an intruder is likely to walk. Large areas in an open floor plan, downstairs

family rooms, and hallways are candidates for Indoor Motion Sensors. Indoor Motion Sensors are not suitable for rooms where pets can enter. Indoor motion sensors can also be used to sound chimes, but cannot be used for intrusion protection and as a chime sensor simultaneously.

Outdoor Motion Sensor

Use Outdoor Motion Sensors to identify motion in a protected outdoor area. Detected motion in this protected area can sound chimes or turn on outside lights. Do not use Outdoor Motion Sensors for intrusion protection.

Smoke Sensor

Smoke Sensors can provide fire alert protection by causing the alarm to sound throughout the house. You can add smoke sensors near sleeping areas and other floors of the house. Avoid areas which could have some smoke or exhaust such as attics, kitchens, above fireplaces, dusty locations, garages, and areas with temperature extremes. In these areas you may want to install Rate-of-Rise sensors to detect extreme temperature changes. See the instructions packaged with the Smoke Sensor for complete placement information.

Refer to the diagram on the next page for specific placement of Smoke Sensors.

ITI ToolBox®

The ITI ToolBox is a Windows®-based program that saves you time by simplifying Control Panel programming. Using only a PC, a modem, and a standard telephone line, ToolBox makes creating new customer accounts and updating the panel settings of existing customers simple and quick. See the ITI ToolBox manual and ToolBox's on-line help for instructions to use ToolBox for programming this Control Panel.

The ITI ToolBox has not been investigated by UL and should not be used on UL Listed Systems.

CAUTION! The Downloader code (option 09) should always be changed to avoid competitor theft.

ITI CS-5000 Receiver

The CS-5000 Receiver is used to monitor this security system.

* = Not Available with Basic Model

ITI HomeLink® Transceiver (IHT)

The ITI HomeLink Transceiver is a radio transmitter/receiver designed to receive signals from the Prince Universal Transmitter (HomeLink), then retransmit the signals to a security system panel, allowing the HomeLink to control the arming, disarming, and light functions of the security system. The IHT also enables the user to control the garage door opener from the HomeLink.

The ITI HomeLink Transceiver has not been investigated by UL and should not be used on UL Listed Systems.

SWS*

The Supervised Wireless Siren (#60-736-95) annunciates alarm appropriate sounds and because of its back-up battery, functions when the power is off. Supervised means that the siren will notify the Control Panel during trouble conditions such as low battery, power failure, etc.

Note: Use of the SWS has not been investigated by UL.

Carbon Monoxide (CO) Alarm

The Learn Mode CO Alarm (#60-652-95) alerts users to hazardous levels of carbon monoxide gas. If dangerous concentrations of gas are present, the CO Alarm's red indicator light comes on, its internal siren goes off, and it transmits an alarm to the Control Panel. The Control Panel sounds its own alarm and calls the central station.

Interrogator® 200 Audio Verification Module (AVM)*

The AVM (#60-687) gives the central station operator the ability to hear what's happening at the premises during an alarm and speak directly to the system user. The operator can then determine how serious an alarm is, find out what kind of help is needed, and dispatch the appropriate assistance. Only one AVM may be installed per Control Panel.

Note: Use of the above module has not been investigated by UL.

Emergency Planning Floor Plan

Use the following guidelines when drawing an emergency planning floor plan for the homeowner:

- Show all building levels.
- Show exits from each room (2 exits per room are recommended).
- Show the locations of all security system components.
- Show the locations of any fire extinguishers.

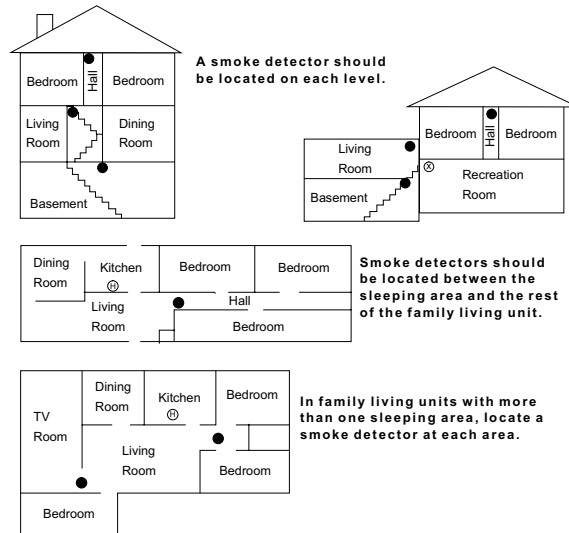

NOTE: Ceiling-mounted smoke detectors should be located in the center of the room or hall, or not less than 4 inches from the wall. When the detector is mounted on the wall, the top of the detector should be 4 to 12 inches from the ceiling.

NOTE: Do not install smoke detectors where normal ambient temperatures are above 100°F or below 40°F. Also, do not locate detectors in front of AC/ Heat registers or other locations where normal air circulation will keep smoke from entering the detector.

NOTE: Additional information on household fire warning is available at nominal cost from: The National Fire Protection Association, Batterymarch Park, Quincy, MA 02269. Request Standard No. NFPA74.

- Required smoke detector
- ⊕ Heat detector
- ⊗ Indicates smoke detector is optional if door is not provided between basement and recreation rooms.

8557144a

Planning Sensor Types & Locations

The first step to an easy and successful installation is to decide what areas or items to protect, which lights or appliances to operate, and the best location for the Control Panel, touchpad, sensors or sirens. Use the previous information and Table 1 on page 5, Device Location Planning, to note your requirements.

Use Table 2 on page 6 and Table 3 on page 7 to determine the appropriate Sensor Type for the sensors you

will be adding. You'll need to understand the application for each sensor. For example, KeyChain Touchpads are typically programmed as sensor type 01 (Portable panic), used to send an intrusion alarm to a central monitoring station. This sensor type is instant intrusion, it does not require restoral or supervisory communication with the Control Panel and it is active in 4 arming levels (disarm, arm doors & windows, arm motion sensors, and arm doors/windows and motions sensors).

Table 1 Sensor/Device Location Planning Table Locations in order as communicated by Control Panel when adding sensors, except that Remote Locations are not used by the Control Panel, but only used here for planning purposes.

Sensor No.	Sensor/Device Name (use Table 2 on page 6 & Table 3 on page 7 to determine sensor type numbers) The following are examples only.	Sensor Type	Remote Locations																						
			Front Door	Back Door	Garage Door	Bedroom	Guest Room	Child's Room	Utility Room	Living Room	Dining Room	Bathroom	Laundry Room	Kitchen	Office	Den	Garage	Special Chime	Basement	Upstairs	Downstairs	Hallway	Medicine Cabinet	Closet	Attic
	KeyChain Touchpad	01	X																						
	Door/Window	13		X																					
1																									
2																									
3																									
4																									
5																									
6																									
7																									
8																									
9																									
10																									
11																									
12																									
13																									
14																									
15																									
16																									
17																									
18																									

Table 1 Sensor/Device Location Planning Table Locations in order as communicated by Control Panel when adding sensors, except that Remote Locations are not used by the Control Panel, but only used here for planning purposes.

Sensor No.	Sensor/Device Name (use Table 2 on page 6 & Table 3 on page 7 to determine sensor type numbers) The following are examples only.	Sensor Type	Remote Locations	Front Door	Back Door	Garage Door	Bedroom	Guest Room	Child's Room	Utility Room	Living Room	Dining Room	Bathroom	Laundry Room	Kitchen	Office	Den	Garage	Special Chime	Basement	Upstairs	Downstairs	Hallway	Medicine Cabinet	Closet	Attic
19																										
20																										
21																										
22																										
23																										
24																										

Table 2 Recommended Sensor Types

Device	Recommended Sensor Type
KeyChain Touchpad	01, 03, 06, 07
Remote Handheld Touchpad and Touchtalk 2-Way RF Touchpad*	01, 03, 06, 07
Indoor Motion Sensor	17 (intrusion), 25 (chime)
Outdoor Motion Sensor	25
Smoke Sensor	26
Exterior Door	10
Interior Door	14
Window Sensor	13
SWS*	33
CO Alarm	34
Freeze & Water Sensors	29

Table 3 Sensor Type Characteristics

Type	Name/Application	Siren Type	Delay	Restoral	Supervisory	Active in Levels
00	Fixed Panic: 24 hour audible fixed emergency button	Intrusion	I	No	Yes	1234
01	Portable Panic: 24 hour audible portable emergency buttons	Intrusion	I	No	No	1234
02	Fixed Panic: 24 hour silent fixed emergency buttons. Status light will not blink.	Silent	I	No	Yes	01234
03	Portable Panic: 24 hour silent portable emergency buttons. Status light will not blink.	Silent	I	No	No	01234
04	Fixed auxiliary: 24 hour auxiliary sensor, such as Pendant Panic	Emergency	I	No	Yes	01234
05	Fixed Auxiliary: 24 hour emergency button. Siren shut off confirms CS report	Emergency	I	No	Yes	01234
06	Portable Auxiliary: 24 hour portable auxiliary alert button	Emergency	I	No	No	01234
07	Portable Auxiliary: 24 hour portable auxiliary button. Siren shut off confirms CS report	Emergency	I	No	No	01234
08	Special Intrusion: such as gun cabinets and wall safes.	Intrusion	I	Yes	Yes	1234
09	Special Intrusion: such as gun cabinets and wall safes.	Intrusion	S	Yes	Yes	1234
10	Entry/Exit Delay: Entry/Exit Delay that require a standard delay time. Chime	Intrusion	S	Yes	Yes	24
13	Instant perimeter: Exterior doors and windows. Chime	Intrusion	I	Yes	Yes	24
14	Instant Interior: Interior doors	Intrusion	F	Yes	Yes	234
15	Instant Interior: Interior PIR motion sensors*	Intrusion	F	No	Yes	234
16	Instant Interior: Interior doors	Intrusion	F	Yes	Yes	34
17	Instant Interior: PIR motion sensors*	Intrusion	F	No	Yes	34
19	Delayed Interior: interior doors that initiate a delay before going into alarm*	Intrusion	S	Yes	Yes	34
20	Delayed Interior: PIR motion sensors that initiate a delay before going into alarm*	Intrusion	S	No	Yes	34
21	Local Instant Interior: 24 hour local alarm zone protecting anything that opens and closes. No Report	Intrusion	I	Yes	Yes	1234
22	Local delayed interior: same as group 21, plus activation initiates a delay before going into alarm. No report.*	Intrusion	S	Yes	Yes	1234
23	Local instant Auxiliary: 24 hour local alarm zone protecting anything that opens and closes.‡ No report	Emergency	I	Yes	Yes	01234
24	Local Instant Auxiliary: 24 hour local alarm zone protecting anything that opens and closes. Sirens shut off at restoral. No report.*	Emergency	I	Yes	Yes	01234
25	Local Special Chime: Notify the user when a door is opened. Sounds emit from a local annunciator.* No report	Three Beeps	I	No	Yes	01234
26	Fire: 24 hour fire, rate-of-rise heat, and smoke sensors§.	Fire	I	Yes	Yes	01234
27	Lamp control or other customer feature.‡ No report	Silent	I	Yes	Yes	01234
28	PIR motion sensor, sound sensor, or pressure mat.‡ No report	Silent	I	No	Yes	01234
29	Auxiliary: Freeze and Water Sensors	Trouble Beeps	I	Yes	Yes	01234
32	PIR motion sensor or sound sensor‡ No report	Silent	I	No	No	01234
33	Supervised Wireless Siren (SWS)	Silent	I	Yes	Yes	01234
34	Carbon Monoxide Alarm	Emergency	I	Yes	No	01234

*This type is not certified as a primary protection circuit for UL-listed systems and is for supplementary use only.

§This type is required for UL-listed residential fire alarm applications.

‡This type has not been investigated by UL.

The arming levels are:

- 0 = Subdisarmed (used to bypass intrusion sensors which are active 24 hrs/day) Only the Master Access Code can enter this level
- 1 = Disarm

- 2 = Arm Doors & Windows
- 3 = Arm Motion Sensors
- 4 = Arm Doors/Windows & Motion Sensors

Delays:

I = Instant Delay (no delay, immediate alarm)

S = Standard Delay (alarm sounds after programmed entry delay time)

F = Follower Delay (alarm sounds immediately if entry/exit delay is not active, otherwise alarm sounds after programmed entry delay time)

Planning Control Locations

Control Panel

Locate the Control Panel so that the alarm sounds can be heard and the Control Panel will be convenient to operate. It must be near an electrical outlet and telephone receptacle.

Remote Handheld Touchpad and Touchtalk 2-Way RF Touchpad*

Locate Remote Handheld Touchpads and the wall-mounted Touchtalk 2-Way RF Touchpad where they will be convenient and offer quick access to the user.

KeyChain Touchpad

KeyChain Touchpads attach to the owner's key ring or can be conveniently carried.

Planning for Lamp*, Appliance*, Wallswitch*, and Universal/Garage Door* Module Control

As you program the modules, the Control Panel asks you to choose the house code, unit number and activation method. Fill out Table 6 on page 9, Home Control Planning Table, before you begin programming.

The system can control 8 individual unit numbers on Lamp, Wallswitch, Appliance, and Universal/Garage Door Modules.

Setting the House Code and Unit Number

Each device (lamp, appliance, garage door, etc.) controlled by the Control Panel must have an identification setting. The modules use two dials to set identification codes: one with letters A through P and one with numbers 1 through 16.

The lettered dial sets the house code. The house code enables the system to differentiate this home from other homes in the area. Set all modules (except the remote siren) and the Control Panel to the same house

code.

The numbered dial sets the unit number. The unit number tells the system which device you want to control. Each unit number should be different (unless you want specific lights or appliances to be activated together). The Control Panel recognizes up to 8 unit numbers for sensor-activated, time-activated and entry/exit delay lights. When unit numbers 9-16 are used for lamp modules, they can only be controlled by an all on or all off command.

A lamp will flash to the arming level if its unit number is set to 10. A lamp set to unit number 10 will flash once if the Control Panel is disarmed, twice if doors & windows are armed, etc.

The remote siren can be set to any unit number to hear alarm sounds. Set it to unit number 9 to also hear arming level beeps, status beeps, and trouble beeps.

To Fill Out the Home Control Planning Table:

Note: Do not use a lamp module to control appliances, use an appliance module, since the wattage rating on Lamp Modules is less than on Appliance Modules.

1. Set the house code on all the Modules, except the remote siren to the same letter.

Note: The house code instructions which come with the Powerhorn Siren won't work with this Control Panel. Follow the house-code instructions given here.

Set the Remote Siren house code to the *next* alphabetical letter. For example, if the house code is B, set the remote siren's house code to C.

2. Set the Module unit numbers.

Note: If you are using a Universal Module to operate a garage door, make sure to assign a unique unit number to this Module choosing from 1-8.

3. List the location of the lamp or appliance in the Location column of Table 6 on page 9.
4. Write the location of each Lamp Module on an adhesive note and label the module.
5. Decide if the device should be activated by sensors, entry/exit delay, time, or a combination. An example of sensor activation is using a motion sensor to turn on a light. Record the information in the appropriate columns.

Use the following three tables to help you further plan module installation.

Table 4 Unit Number Assignments*

Unit Number (1 through 16)	Result
1-8	Used for sensor-activated, time-activated, and entry/exit delay lights. Sensor-activated lights are enabled and disabled pressing the LIGHTS Sensor Activated button on the Control Panel. Time-activated lights are enabled and disabled by pressing the LIGHTS Time Activated button on the Control Panel. If using the universal module to operate a garage door, be sure to assign a unique unit number. The STAR button on the KeyChain Touchpad activates the universal module to open the garage door or to turn on special lights if programmed.
9-16	Used for lamp modules and controlled by an all on or all off command.
9	Used for remote siren to hear arming level beeps, status beeps and trouble beeps. If set to any other number the user will hear only alarm sounds.
10	Lamps will flash to arming level.

Table 5 House Code Assignments*

House Codes	Results
A through O	Set all modules to the same house code except the remote sirens
Next Higher House Code	Remote Siren needs to be the next higher alphabetical letter

Table 6 Home Control Planning Table*

Module			Activated by		Time Activated	
Unit #	Type	Location	Sensor	Entry/Exit	Start Time	Stop Time
Example	Lamp	Hall lamp	Motion	Yes	8 p.m.	10:30 p.m.
1						
2						
3						
4						
5						
6						
7						
8						

* = Not Available with Basic Model

Planning System Access Codes

Use the following to plan system Access Codes. Fill out Table 7 on page 10 to use when programming these codes.

Utility Access Code 1

This access code is used during installation. The default utility access code is 4321. This code can be used for all programming.

Utility Access Code 2

The default access code is 4321. This access code is used for all programming except changing utility access code 1 and changing options 4, 5, 6, 8, 9, 12, and 13.

Master Access Code

The default Master Access Code is 1234. This user code is used to: disarm the Control Panel, subdisarm the Control Panel, program options 1 through 3, 36, 37, 41 - 43, program light control, set the system clock, program the master code, program access codes 1-5, program the panic code, and perform a sensor or phone test.

Note: If the installer deletes the master access code, the owner may enter program mode by pressing cancel.

Access Codes (1 - 5)

The Control Panel can have up to 5 secondary user access codes. These could be used by children, a baby sitter, or a service person. These codes cannot be used for programming.

Panic Code

The Panic Code is able to disarm or subdisarm the panel and send a silent alarm to the Central Station. There will be no indication of an alarm at the panel.

Table 7 System Access Codes

Type	Default	Installer Settings
Utility Access Code 1	4321	
Utility Access Code 2	4321	
Master Access Code	1234	
Access Code 1	None	
Access Code 2	None	
Access Code 3	None	
Access Code 4	None	
Access Code 5	None	
Panic Code	None	

Planning System Options

Use the following to plan system Options. See Table 18 on page 19 for a complete listing of all system options and their characteristics. Fill out the last column of this table to use when programming.

Option 01: Panel Piezo Beeps

Add turns on panel beeps that sound when an access code is entered or when the arming level is changed. The arming buttons will cause beeps according to the arming level. See Table 8 on page 11 for a detailed explanation of panel piezo beeps.

Delete turns off panel piezo beeps.

Option 02: Panel Voice

Add enables the panel's voice.

Delete disables the panel's voice.

Note that the panel voice is always on for status messages, open sensor responses, and when in program mode.

Table 8 Panel Piezo Beeps

Activity	Beep Response
ARM Doors & Windows	Exit delay beeps sound 2 times when you arm and 2 times at the end of the delay time; Entry delay beeps sound 2 times every 5 seconds and 2 times per second during the last 10 seconds
ARM Motion Sensors	Exit delay beeps sound 3 times when you arm and 3 times at the end of the delay time; Entry delay beeps sound 3 times every 5 seconds and 3 times per second during the last 10 seconds
ARM Doors/Windows & Motion Sensors	Exit delay beeps sound 4 times when you arm and 4 times at the end of the delay time; Entry delay beeps sound 4 times every 5 seconds and 4 times per second during the last 10 seconds
DISARM	1 beep
CHIME DOORS	2 beeps (when programmed)
CHIME SPECIAL MOTION	3 beeps (when programmed)
Trouble Beeps	6 beeps every minute. Press SYSTEM STATUS button to stop beeps for 4 hours
No Activity	20 beeps every minute for 5 minutes (when programmed)

Option 03: Latchkey

Add programs the Latchkey time. If Latchkey is enabled when the Control Panel is armed and the Control Panel is not disarmed by the preprogrammed time, the Control Panel will call in a Latchkey alarm at the programmed time.

The system clock must be set for Latchkey to function.

Delete turns off this option and Latchkey cannot be enabled when the Control Panel is armed.

Option 04: Primary Phone Number

Add programs the primary phone number to be called when there is an alarm. The phone number will call the central station.

Delete removes the primary phone number.

Option 05: Secondary Phone Number

Add and *Delete* function the same as they do for the primary phone number. This number can be to a numeric pager or a central station. When using it to call a numeric pager, program this phone number with 2 pauses (press the test button to program a pause) at the end of the number. Some pagers may require 3 or 4 additional pauses be appended to the phone number.

Set Phone Mod 2 (option 13) to 8 or 9. The Control Panel will call a numeric pager twice for each report. Pagers that require the Control Panel to dial more than 22 digits will not work. Silent alarms report to a pager as an intrusion alarm. See Table 17 on page 17 for more reporting information.

Option 06: Downloader Phone Number

Programs the ITI ToolBox Downloader telephone number.

Add and *Delete* function the same as they do for the primary phone number.

Option 07: Account Number

Add programs the account number.

Delete resets it to 00000.

Option 08: Phone Lock

Add enables phone lock. Options 04, 05, 06, 08, 09, 12, and 13 will not be cleared if the system memory is cleared and phone lock is on.

Delete disables phone lock.

Option 09: DL Code (Downloader Code)

Add programs the downloader access code. The Downloader Code is used during Control Panel programming with the ITI ToolBox. The Control Panel’s downloader code must match the downloader access code in the ITI ToolBox account in order to program the Control Panel using the ITI ToolBox.

Delete resets the code to 12345.

CAUTION! The downloader code should always be changed to avoid competitor theft.

Option 10: Entry Delay

Add programs the entry delay. Enter time in seconds. The range is 005-120 seconds (3 digits must be entered). Entry delay beeps will sound when the delay is activated. The panel will sound beeps corresponding to the arming level every 5 seconds. For example, you will hear 2 beeps every 5 seconds if the panel is armed to level 2. The entry delay beeps will sound every second during the last 10 seconds of the delay to warn the user that the delay is about to expire.

Delete sets the delay to 5 seconds.

For UL listed systems, the entry delay should not exceed 45 seconds.

Option 11: Exit Delay

Add programs the exit delay. Enter time in seconds. The range is 005-120 seconds (3 digits must be entered). The exit delay beeps will occur when the panel is armed and when the exit delay has expired. The exit delay beeps correspond to the arming level. For example, you will hear 2 beeps if arming to level 2. The panel will sound three sets of warning beeps if a sensor that requires restoral is open during the exit delay if auto arm is off (option 38). The panel will protest if a sensor that requires restoral is open during the exit delay if auto arm is on (option 38).

Delete sets the delay to 5 seconds.

For UL listed systems, the exit delay should not exceed 45 seconds.

Option 12: Phone Mod 1

Add sets the report content and format which the primary phone number uses. The range is 0-3.

Delete sets the phone mod to 0.

Table 9 Phone Mod 1

Enter #	Reports	Format
0	All	SIA
1	All	Contact ID
2	Alarms	SIA
3	Alarms	Contact ID

Alarms include: Fire, Intrusion, Emergency, Silent, and Alarm Cancels.

Non-Alarms include: Latchkey, No Activity, Openings, Closings, Fail to Open, Fail to Close, Force Armed, AC Power Failure, CPU Low Battery, and Trouble Restorals.

All includes: Alarms and Non-Alarms.

UL has only verified compatibility with the ITI CS5000 Digital Alarm Communicator Receiver.

Option 13: Phone Mod 2

Add sets the report content and format that the secondary phone number uses. Range is 0-9.

Delete sets the phone mod to 0.

Table 10 Phone Mod 2

Enter #	Reports	Format
0	All	SIA
1	All	Contact ID
2	Alarms	SIA
3	Alarms	Contact ID
4	Non-Alarms	SIA
5	Non-Alarms	Contact ID
6	Phone 1 failure	SIA
7	Phone 1 failure	Contact ID
8	Latchkey, No Activity, Phone Test, Openings, Closings, Fail to Open/Close, AC Power Restorals/Failures	Pager
9	Same as Phone Mod 8 plus Alarms	Pager

Option 14: DTMF Dialing

Add enables DTMF dialing.

Delete enables pulse dialing.

Option 15: No Activity

Add enables the no activity time-out. Program the no activity time-out in hours. The range is 02-24 hours (2 digits must be entered). A no activity alarm will be called in if the programmed amount of time passes and the panel is in level 0, 1, or 2 and no activity has occurred.

No activity is defined as: a key has not be pressed from the panel or a touchpad and a sensor has not been tripped (except one that is type 25).

Delete disables the no activity time-out.

Option 16: Auto Phone Test

Add enables the auto phone test. Program the auto phone test frequency in days. The range is 001 - 254 days (3 digits must be entered). The start time for the auto phone test begins 12 hours after the Control Panel is powered up.

Delete disables auto phone test.

Option 17: Dialer Delay

Add enables the dialer delay. Program the delay in seconds. The range is 001-120 seconds (3 digits must be entered). This option causes the Control Panel to wait the programmed time before calling the central station. Alarms activated by sensors that are type 0-8, 26, and the emergency button on the front of the control panel or on any of the touchpads will always be called in immediately.

Delete disables the dialer delay.

For UL installations, dialer delay time cannot be greater than 45 seconds.

Note: The Control Panel will not wait the programmed dialer delay to call in an alarm if the Control Panel is disarmed before the dialer delay expires and opening reports are on. Both the alarm and opening report will be called in immediately.

Option 18: Alarm Cancel

Add enables alarm cancel. Program the time in minutes. If the Control Panel is disarmed from an alarm state within the programmed time, the Control Panel will send an alarm cancel message. The range is 001-254 minutes (3 digits must be entered). If programmed to 255, cancels will always be sent to the central station.

Delete disables the alarm cancel.

Option 19: Supervisory Time (SUPSYNC)

Add sets the supervisory time. Program the time in hours. The range is 02-24 hours (2 digits must be entered).

Delete resets SUPSYNC to 2 hours.

For UL listed systems, the SUPSYNC shall not exceed 4 hours.

Option 20: Manual Phone Test

Add allows the user to perform a manual phone test.

Delete disables manual phone test.

Option 21: Opening Reports (Disarming Reports)

Add enables opening reports. Opening reports will be sent to the central station if the Control Panel is disarmed from a higher arming level.

Delete disables opening reports.

Option 22: Closing Reports (Arming Reports)

Add enables closing reports. Closing reports will be sent to the central station if the Control Panel is armed to level 2, 3, or 4.

Delete disables closing report.

Table 11 User Codes for Opening and Closing Reports

Arm or Disarm with:	Reports as User:
Control Panel, Touchtalk 2-Way RF Touchpad, & Handheld Touch Pad	0
FOB	1-24 (sensor number)
Master Code	30
Access Codes 1-5	31-35
Panic Code	36

Option 23: Force Armed

Add enables force armed reports. A force armed report will be sent to the central station if a sensor is indirectly bypassed.

Delete disables force armed reports.

Option 24: AC Power Failure

Add enables AC power failure reports. The panel LEDs will shut off and an AC power failure report will be sent to the central station if the Control Panel has lost power for 15 minutes. The Control Panel will report AC power restoral when power returns to the Control Panel.

Delete disables AC power failure and restoral reports.

Option 25: CPU Low Battery

Add enables CPU low battery reports. A low battery report will be sent to the central station when the Control Panel's lithium battery voltage drops below 6.2 volts or the rechargeable battery drops below 6.5 volts.

Delete disables CPU low battery reports.

Option 26: Fail to Communicate

Add enables fail to communicate. If the Control Panel is not able to connect to the CS when it's trying to report an alarm, the Control Panel will indicate this with trouble beeps and in the status message.

Delete disables fail to communicate.

Option 27: Ring/Hang/Ring

Add enables ring/hang/ring to use with ToolBox and remote phone access. This feature is useful when programming a Control Panel in a home with an answering machine.

Delete disables ring/hang/ring. The Control Panel will not answer.

Program ring/hang/ring by number.

Table 12 Ring/Hang/Ring Program Numbers

Program #	Control Panel will answer after:
1	ring/hang/ring or 10 rings
2	ring/hang/ring/hang/ring or 10 rings
3	ring/hang/ring/hang/ring/hang/ring or 10 rings
4	10 rings

If ring/hang/ring is programmed as:

Program # 1 -

1. Call the Control Panel and let the phone ring twice then hang up.
2. Wait 10-40 seconds and call the Control Panel

again.

3. The Control Panel should answer on the first ring.

Program # 2 - Repeat steps 1 & 2 before the Control Panel will answer.

Program # 3 - Repeat steps 1 & 2 twice before the Control Panel will answer.

The following table identifies the phone commands to be used when using remote phone control.

Table 13 Phone Commands for Remote Access*

Control Panel Function	Phone Command
DISARM	* + CODE + 1
ARM Doors/Windows	* + CODE + 2
ARM Doors/Windows with No Entry Delay	* + CODE + 2 + 2
ARM Motion Sensors	* + CODE + 3
ARM Motion Sensors with Latchkey	* + CODE + 3 + 3
ARM Doors/Windows and Motion Sensors	* + CODE + 2 + 3
ARM Doors/Windows with No Entry Delay and Motion Sensors with Latchkey	* + CODE + 2 + 2 + 3 + 3
Toggle Lights	* + CODE + 0
System Status	* + CODE + # + 1
Audio Verification	* + CODE + 5 + X (X = a command from the audio verification command set). See Table 15 on page 15

CODE = any access code except utility access codes 1 and 2

Option 28: No Delay from KeyChain Touchpad

Add arms with no entry delay when using the Key-Chain Touchpad.

Delete arms with an entry delay when using the Key-Chain Touchpad.

Option 29: Control Panel Alarms

Add enables the Control Panel's piezo to sound alarms. Alarms will sound from the Control Panel.

Delete disables the Control Panel’s piezo from sounding alarms. Alarms will not sound from the Control Panel.

For UL listed systems, at least one listed external audible signal device shall be used if the external piezo is disabled.

Option 30: Panic Alarms

Add enables all panic alarms (intrusion, auxiliary, and fire) initiated from the Control Panel. Use the decal included with the Control Panel if this option is on.

Delete disables intrusion, auxiliary, and fire panic buttons on the control panel. The emergency button on the control panel is always active.

Option 31: Day of Week

Add will program the day of week based on a programmed number. The day of week may be viewed in the event buffer using ToolBox.

Table 14 Day of Week by Number

0	Sunday
1	Monday
2	Tuesday
3	Wednesday
4	Thursday
5	Friday
6	Saturday

Delete sets day of week to 0.

Option 32: 300 Baud

Add enables 300 baud communication. Enable this option for faster communication

Delete enables 110 baud communications

Option 33: 2-Way Voice*

Add enables 2-way voice communications between the security system site and a monitoring station. 2-way voice is also available to the owner if Ring/Hang/Ring (option 27) is on.

Delete disables 2-way voice.

Do the following to conduct an audio session:

1. After the panel has completed reporting the

alarm, pick up the CS phone.

2. Press the * button on the phone to start the audio session.
3. Press 1 or 0 to speak and 3 or 6 to listen.
4. Press 99 to terminate the session.

Note: To conduct an audio session using remote phone access see Table 13 on page 14.

Table 15 Audio Verification Set

Phone Button(s)	Audio Verification System
1	Speak
3 or 6	Listen
7	Extend session for 90 more seconds
88	Terminates session with call back (the panel will answer on the first ring if called within 5 minutes)
99	Terminates session with no call back

Option 34: Fail to Open

Add enables fail to open. If the panel has not been disarmed by the programmed opening time, the panel will call in a fail to open alarm to the Central Station and/or a pager.

Delete disables fail to open.

Option 35: Fail to Close

Add enables fail to close. If the panel has not been armed by the programmed opening time, the panel will call in a fail to close alarm to the Central Station and/or a pager.

Delete disables fail to close.

Option 36: Sensor Activated Light Lockout Start Time*

Add enables sensor activated light lockout start time. The panel will not turn on a light between the programmed start time (option 36) and the programmed stop time (option 37), even if sensor activated lights are on. **Both options must be programmed for this option to work correctly.**

Delete disables sensor activated light lockout start time. The panel will turn on a light activated by a sensor at all times if sensor activated lights are enabled.

* = Not Available with Basic Model

Option 37: Sensor Activated Light Lockout Stop Time*

Add enables sensor activated light lockout stop time. The panel will not turn on a light, between the programmed start time (option 36) and the programmed stop time (option 37), even if sensor activated lights are on. **Both options must be programmed for this option to work correctly.**

Delete disables sensor activated light lockout stop time. The panel will turn on a light activated by a sensor at all times if sensor activated lights are enabled.

Option 38: Auto Arm

Add enables auto arm. Any sensor that requires restoral and is open when the panel is armed will automatically be bypassed when the panel is done protesting. The panel will protest for 4 minutes, then auto arm. Pressing the ARM Doors & Windows button a second time will stop the control panel protest and auto arm the system. Pressing this button a third time will arm with no entry delay. The panel will go into alarm if an instant alarm sensor is opened during an exit delay. A sensor learned as type 26 can never be bypassed.

Delete disables auto arm. Any sensor that requires restoral and is open when the exit delay expires will automatically be bypassed. Beeps indicating the arming level will sound four times when the control panel is armed and one time when the exit delay ends. The panel will go into alarm if an instant alarm sensor is opened during an exit delay. A sensor learned as type 26 can never be bypassed.

Option 39: Siren Time Out

Add programs siren time out from 1 to 30 minutes. The default siren time out is 4 minutes.

Delete siren never time out.

Option 40: Trouble Beeps

Add enables trouble beeps. If there is a trouble condition, six beeps will sound every minute. If the panel is armed, disarmed, or status is pressed, the trouble beeps will stop and then resume 4 hours later.

Trouble beeps will be heard if:

- There is AC power failure.
- The CPU battery is low.
- There is a sensor failure.

- There is sensor trouble.
- There is a fail to communicate problem.
- The no activity timer has timed out. Trouble beeps will continue for 5 minutes and if the panel does not see activity, the trouble beeps will stop and the panel will call the CS to report the no activity.

Delete disables trouble beeps, so that if a problem occurs the control panel will not notify the owner with trouble beeps.

Option 41: Chime Voice

The panel has two chime modes which may be enabled by pressing the appropriate button on the panel.

CHIME Doors

Chime doors is a chime sound (two beeps) that will be emitted from the interior siren output, the panel siren, SWS, and the X-10 powerhorn siren (if set to unit #9) when a door/window sensor which is type 10 or 13 is activated. If there are no sensors learned as type 10 or 13, this function will not be available. The panel will announce which sensor was tripped if chime voice is on and the sensor was opened while the panel is disarmed.

CHIME Special Motion*

Chime special motion is a chime sound (three beeps) that will be emitted from interior siren output, the panel siren, SWS, and the X-10 powerhorn siren (if set to unit #9) when a chime sensor that is type 25 is activated (the alarm state is sent to the panel). If there are no sensors learned as type 25, this function will not be available. The panel will announce which sensor was tripped if chime voice is on and the sensor was opened while the panel is disarmed.

Add enables chime voice. The panel will announce which chime sensor has been tripped if the chime feature is enabled.

Delete disables chime voice. The panel will not announce which chime sensor has been tripped even if the chime feature is enabled.

Option 42: Speaker Level*

Add sets speaker level to the high voice level.

Delete sets the speaker level to the low voice level.

Option 43: Pager Phone Number

Add enables pager phone number. Program the pager phone number. The phone number can only call a pager. Some pagers may require 3 or 4 additional pauses be appended to the phone number.

Delete disables pager phone number. The phone number will not be called in an alarm situation.

Option 44: Pager Phone Mod 3

Add enables pager phone mod 3 sets the report content and format the pager phone number uses. Use the following table to determine the value to enter.

Delete sets pager phone mod to 8.

Table 16 Pager Phone Mod Format

Enter #	Reports	Format
8	Latchkey, No Activity, Phone Test, Openings, Closings, Fail to Open/Close, AC Power Restorals/Failures	Pager
9	The same as Phone Mod 8 plus Alarms	Pager

Table 17 Pager Reporting Message

Use the following table to determine what the numeric message is reporting.

Reports	Numeric Message
Phone Test	-101 -101
AC Power Restoral	-102 -102
AC Power Failure	-103 -103
Latchkey	-104 -104
No Activity	-105 -105
Panic Code	-106 -106
Emergency	-107 -107
Intrusion	-108 -108
Fire	-109 -109
Openings	-110 -110
Closings	-111 -111
Fail to Open	-112 -112
Fail to Close	-113 -113

Option 45: Sensor Alarm Restoral

Add enables sensor alarm restoral. This sends a report to the central station when a restoral sensor that is in alarm is restored.

Delete disables sensor alarm restoral reports.

Option 46: Fire Shutdown - AVM*

Add enables fire shutdown - AVM. This option allows the panel to turn off the sirens during a two way voice session with the user and the central station. Beeps will sound every 10 seconds while the sirens are off.

Delete disables fire shutdown - AVM. If this option is turned off, the sirens will not shut off during a two way voice session.

Option 47: AVM Mode*

Add enables AVM mode. This allows the central station to hang up and call the panel back for a two way voice session.

Delete disables AVM mode. When this option is off, the two way session will start immediately.

Option 48: Panic Talk*

Add enables panic talk. This allows the central station to listen and talk to the user during a silent alarm. (Sensor type 02 or 03 or if the Panic Code was entered).

Delete disables panic talk. When this option is turned off, the central station may only listen during a silent alarm.

Option 49: Rechargeable Battery

Add enables the rechargeable battery to be used.

Delete enables the lithium battery to be used.

Option 50: RF Jam Detect

Add enables RF jam detect. This allows the Control Panel to detect RF interference. The control panel will call the Central Station if RF jam detect is on and the panel receives a constant 319.5 MHz signal.

Option 50 Detected is the status message for this option.

Delete disables RF jam detect. When this option is turned off, the Control Panel is unable to detect RF interference.

* = Not Available with Basic Model

Option 51: 24 Hour Battery Test

Add sets battery test period to 24 hours. This feature is only useful when using a non-rechargeable Ultra-Life 9V lithium battery because it extends battery life.

Delete sets battery test period to 4 hours.

Option 52: High Level Status

Add sets status beeps and arming level beeps to high volume.

Delete sets status beeps and arming level beeps to low volume.

Option 53: Hardwire Siren Supervision

Add turns hardwire siren supervision on. Turn this option on if installing a hardwire siren and supervision is desired.

See the “Wiring the Control Panel” on page 21 for the correct EOL resistor connection.

Delete turns hardwire supervision off and is the appropriate setting if hardwire sirens are not being connected.

Reset Memory to the Factory Defaults

If it becomes necessary to set **all** programming back to the factory defaults, do the following:

1. Open the Control Panel cover.
2. Unplug the transformer and the battery.
3. Simultaneously press **Cancel**, **Clock Set**, and **Minutes**.
4. Restore power to the panel with either the battery or the transformer while pressing these three buttons.
5. Plug in the transformer or connect the battery.

NOTE: If Phone Lock is on, options 04, 05, 06, 08, 09, 12, and 13 will not reset to their defaults.

Table 18 Programmable Options

Op- tion #	Function	Default	Delete	Range	Who Can Change: U1 - Utility Access Code 1; U2 - Utility Access Code 2; M - Master;	Installer Settings
01	Panel Piezo Beeps	On	Off	On/Off	U1 U2 M	
02	Panel Voice	On	Off	On/Off	U1 U2 M	
03	Latchkey Option	Off	Off	12:00 AM- 11:59 PM	U1 U2 M	
04	Primary Phone Number	None	None	22 digits	U1	
05	Secondary Phone Number	None	None	22 digits	U1	
06	Downloader Phone Number	None	None	22 digits	U1	
07	Account Number	00000	00000	00000- 99999	U1 U2	
08	Phone Lock	Off	Off	On/Off	U1	
09	Downloader Code	12345	12345	00000- 99999	U1	
10	Entry Delay	030 sec	005 sec	005-120 sec	U1 U2	
11	Exit Delay	030 sec	005 sec	005-120 sec	U1 U2	
12	Phone Mod 1	0	0	0-3	U1	
13	Phone Mod 2	0	0	0-9	U1	
14	DTMF	On	Pulse	On/Off	U1 U2	
15	No Activity Report	Off	Off	02-24 hrs	U1 U2	
16	Auto Phone Test (Must be enabled for UL Listed systems)	Off	Off	001-254 days	U1 U2	
17	Dialer Delay	Off	Off	001-120 sec	U1 U2	
18	Alarm Cancel Report	Off	Off	001-255 min	U1 U2	
19	Supervisory Time (SUPSYNC)	12 hrs	02 hrs	02-24 hrs	U1 U2	
20	Manual Phone Test	On	Off	On/Off	U1 U2	
21	Opening Reports	Off	Off	On/Off	U1 U2	
22	Closing Reports	Off	Off	On/Off	U1 U2	
23	Force Armed Report	Off	Off	On/Off	U1 U2	
24	AC Power Failure Report (Must be enabled for UL Listed systems)	Off	Off	On/Off	U1 U2	
25	CPU Low Battery Report (Must be enabled for UL Listed systems)	On	Off	On/Off	U1 U2	
26	Fail to Communicate (Must be enabled for UL Listed systems)	On	Off	On/Off	U1 U2	
27	Ring/Hang/Ring	1	Off	1-4	U1 U2	

Table 18 Programmable Options

Op-tion #	Function	Default	Delete	Range	Who Can Change: U1 - Utility Access Code 1; U2 - Utility Access Code 2; M - Master;	Installer Settings
28	No Delay from KeyChain Touchpad	Off	Off	On/Off	U1 U2	
29	Panel Piezo Alarm	On	Off	On/Off	U1 U2	
30	Panic Alarms	Off	Off	On/Off	U1 U2	
31	Day of Week	0	0	0-6	U1 U2	
32	300 Baud Central Station Communications	On	110 Baud	On/Off	U1 U2	
33	Audio Verification*	Off	Off	On/Off	U1 U2	
34	Fail to Open	Off	Off	12:00 AM - 11:59 PM	U1 U2	
35	Fail to Close	Off	Off	12:00 AM - 11:59 PM	U1 U2	
36	Sensor Activated Light Lockout Start Time*	Off	Off	12:00 AM - 11:59 PM	U1 U2 M	
37	Sensor Activated Light Lockout Stop Time*	Off	Off	12:00 AM - 11:59 PM	U1 U2 M	
38	Auto Arm	Off	Off	On/Off	U1 U2	
39	Siren Time Out	04 min	Siren never times out	01 - 30 minutes	U1 U2	
40	Trouble Beeps	On	Off	On/Off	U1 U2	
41	Chime Voice	Off	Off	On/Off	U1 U2 M	
42	Speaker Level*	On	Low	On/Off	U1 U2 M	
43	Pager Phone Number	Off	Off	22 digits	U1 U2 M	
44	Pager Phone Mod 3	9	9	8 or 9	U1 U2	
45	Sensor Alarm Restoral	Off	Off	On/Off	U1 U2	
46	Fire Shutdown - AVM*	Off	Off	On/Off	U1 U2	
47	Audio Verification Mode*	Off	Off	On/Off	U1 U2	
48	Panic Talk - AVM*	Off	Off	On/Off	U1 U2	
49	Rechargeable Battery	Off	Off	On/Off	U1 U2	
50	RF Jam Detect	Off	Off	On/Off	U1 U2	
51	24 Hour Battery Test	Off	Off	On/Off	U1 U2	
52	High Level Status	Off	Off	On/Off	U1 U2	
53	Hardwire Siren Supervision	Off	Off	On/Off	U1 U2	

Wiring the Control Panel

This section describes how to:

- connect hardwire interior and exterior sirens (if being installed)
- connect hardwire sensors
- connect garage door opener module
- connect the power transformer
- connect the backup battery
- connect a phone line

Connecting Hardwire Interior Sirens

The following ITI interior sirens may be used with this Control Panel:

- LD105 Siren (13-374)
- Phone Jack Siren (60-683)

Turn option 53 on for siren supervision. When option 53 is on and a hardwire exterior siren is not connected, a 47k ohm resistor (two 47k ohm resistors are shipped with the Control Panel) must be connected across the positive and negative terminals, SYSTEM STATUS will say *Module 1 failure*.

Follow the siren installation instructions included with the siren for siren specific EOL resistor connections. Only one hardwire interior siren may be connected. See figure 2 below for a generalized wiring connection.

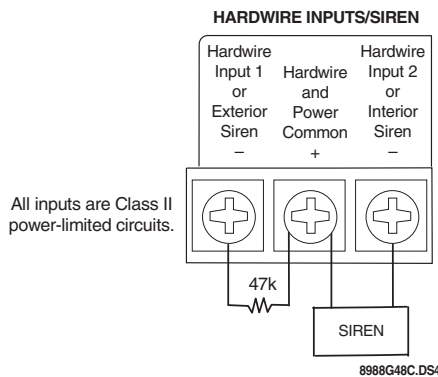

Figure 2. Supervised Interior Siren Connections

Connecting a Hardwire Exterior Siren

The following ITI exterior siren may be used with this Control Panel:

- Hardwire Exterior Siren (13-046)

Turn option 53 on for siren supervision. When option 53 is on and a hardwire interior siren is not connected, a 47k ohm resistor (two 47k ohm resistors are shipped with the Control Panel) must be connected across the positive and negative terminals. If a 47k ohm resistor or a siren is not connected to the interior siren terminals, SYSTEM STATUS will say *Module 2 failure*.

Wire sirens to be supervised by using a 4.7k ohm EOL resistor, included with the siren.

Only one hardwire exterior siren may be connected. See figure 3 below for wiring connections.

Note: Two 47k ohm resistors are included with the Control Panel. These should not be used for EOL resistors when wiring sirens.

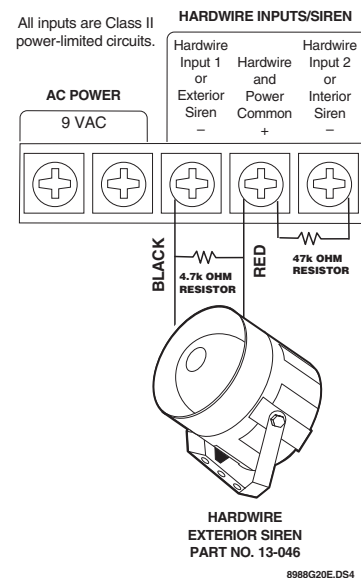

Figure 3. Supervised Exterior Siren Connections

Connecting Hardwire Sensors

This section shows how to wire hardwire sensors to the Control Panel. For more programming information on installing hardwire devices, “Programming Sensors” on page 25. Wire sensors to be supervised by using a 47k Ohm resistor (included with the Control Panel).

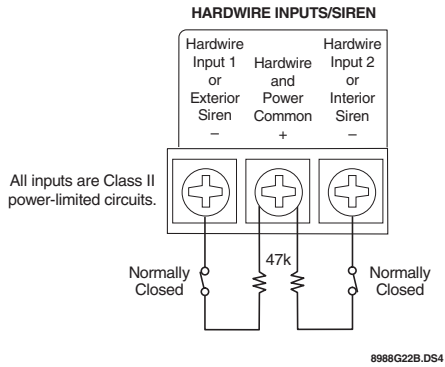

Figure 4. Wire Hardwire Sensors Normally Closed

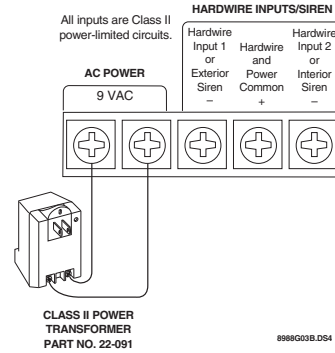

Figure 5. Power Transformer Control Panel Connections

Connecting the Universal/Garage Door Opener Module*

Use the following to connect a universal module to be used to open a garage door:

1. **Set the unit code** of the universal module to a unique unit number between 1 and 8.
2. **Set the house code** to the house code for the installation.
3. **Set the module's switches** to momentary and relay only.
4. **Connect the terminals on the universal module** to the button terminals on the garage door opener.
5. **Plug the universal module into a wall outlet.**

Note: See the "Programming Light and Appliance Controls*" on page 26 to program a KeyChain Touchpad to open a garage door.

Connecting the Power Transformer

Connect the power transformer as shown in Figure 5. Plug the transformer into an unswitched outlet

Note: Failure to terminate unused inputs as shown will cause the Control Panel to indicate module 1 and module 2 failure.

Connecting the Backup Batteries

Installing a Non-rechargeable Battery

Connect a 9-Volt lithium battery (ITI #34-037) to the battery strap as shown in Figure 6.

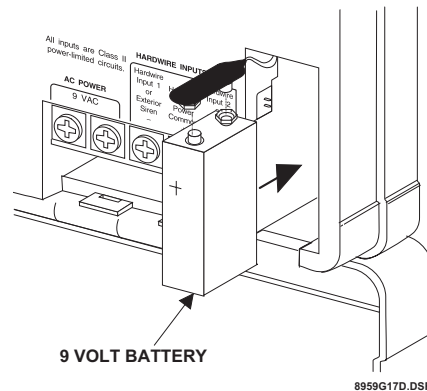

Figure 6. Control Panel Battery Installation

Note: The Control Panel will initially indicate a low battery by lighting the SYSTEM STATUS button. If this button is pressed the Control Panel will announce, *System low battery*.

The Control Panel does a battery test every 4 hours and will clear the status message if the battery is good.

Perform a sensor test, "Testing Sensors" on page 30, to perform an immediate battery test.

Installing a Rechargeable Battery

Plug the AC power transformer into an unswitched outlet.

Connect the rechargeable battery (#34-051 or #34-052) as shown below in 7 Option 49 must be turned on in order for the charging circuit to be activated.

The rechargeable battery will be fully charged after nine hours. The system will have a low battery report when checking system status until the battery is fully charged.

If a rechargeable battery needs replacing, the control panel must be power-cycled in order for the new battery to become fully charged. To power-cycle the control panel do the following:

1. Unplug the AC power transformer and battery.
2. Plug in the AC power transformer.
3. Plug in the new rechargeable battery.

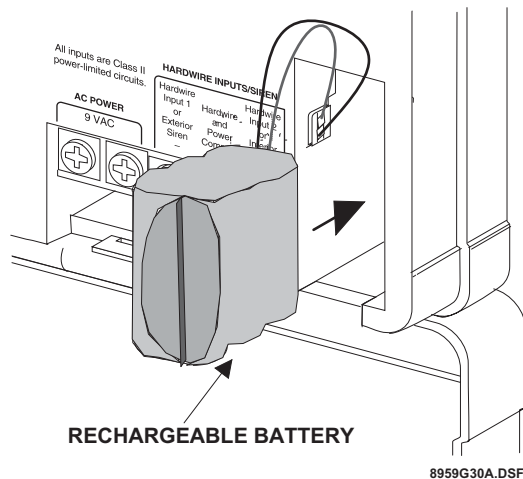

Figure 7. Rechargeable Battery Installation

Connecting the Phone Line to the Control Panel

If the system will be monitored by a central monitoring station, you must install an RJ-31X jack between the telephone company (TELCO) block and the Control Panel. The jack must be located within 5 feet of the Control Panel.

Installing an RJ-31X Jack

Install and wire the RJ-31X jack as shown in Figure 8.

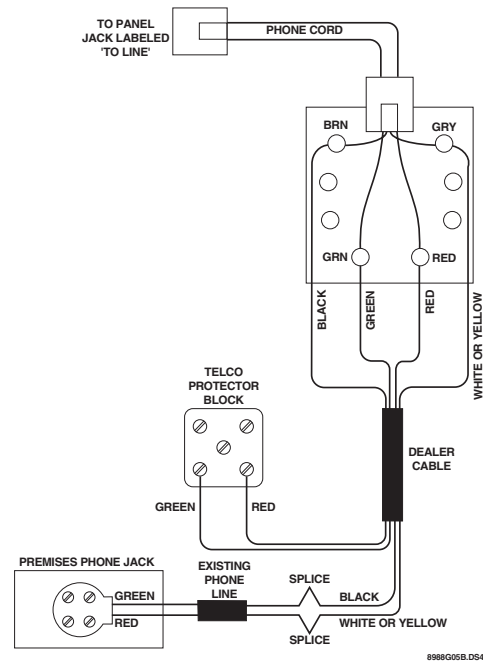

Figure 8. RJ-31X Wiring Diagram

Connecting the Phone Line to the Control Panel

1. Plug one end of the phone cord (included with the Control Panel) into the RJ-31X jack.
2. Plug the other end of the phone cord into the Control Panel phone jack labeled TO LINE.
3. When looking at the back of the Control Panel, the top block is used to connect the phone to the Control Panel, and is labeled TO PHONE, the bottom block is used to connect the Control Panel to the wall phone jack, and is labeled TO LINE.

Programming Overview

These instructions tell you how to set up for programming and to put the Control Panel in program mode.

1. Arrange the sensors, modules, Control Panel, and user controls on a table.
2. Open the Control Panel cover.
3. Enter Utility Access Code 1 (default is 4321) using red numbered keys.

Note:The default for utility access codes 1 and 2 is 4321.

Note:The default master access code is 1234.

You are now in program mode.

Programming is easy if you understand the flow from left to right when using the programming buttons. Follow the programming arrows or use the flow diagrams to the right of the programming buttons. The Control Panel will voice prompt you through programming.

To get you started:

1. Press **Add or Delete** from the Start Menu.
2. Press **Option #, Sensor/Remote, Access Code or Light Control** from the Main Menu.

The system response at this point depends upon what button you just pressed. Follow the voice prompts and programming arrows to continue.

Program the Control Panel in this order:

1. Sensors
2. House Code
3. Light & Appliance Control
 - Entry/Exit activated lights
 - Sensor activated lights
 - Time activated lights
4. Options
5. Access Codes

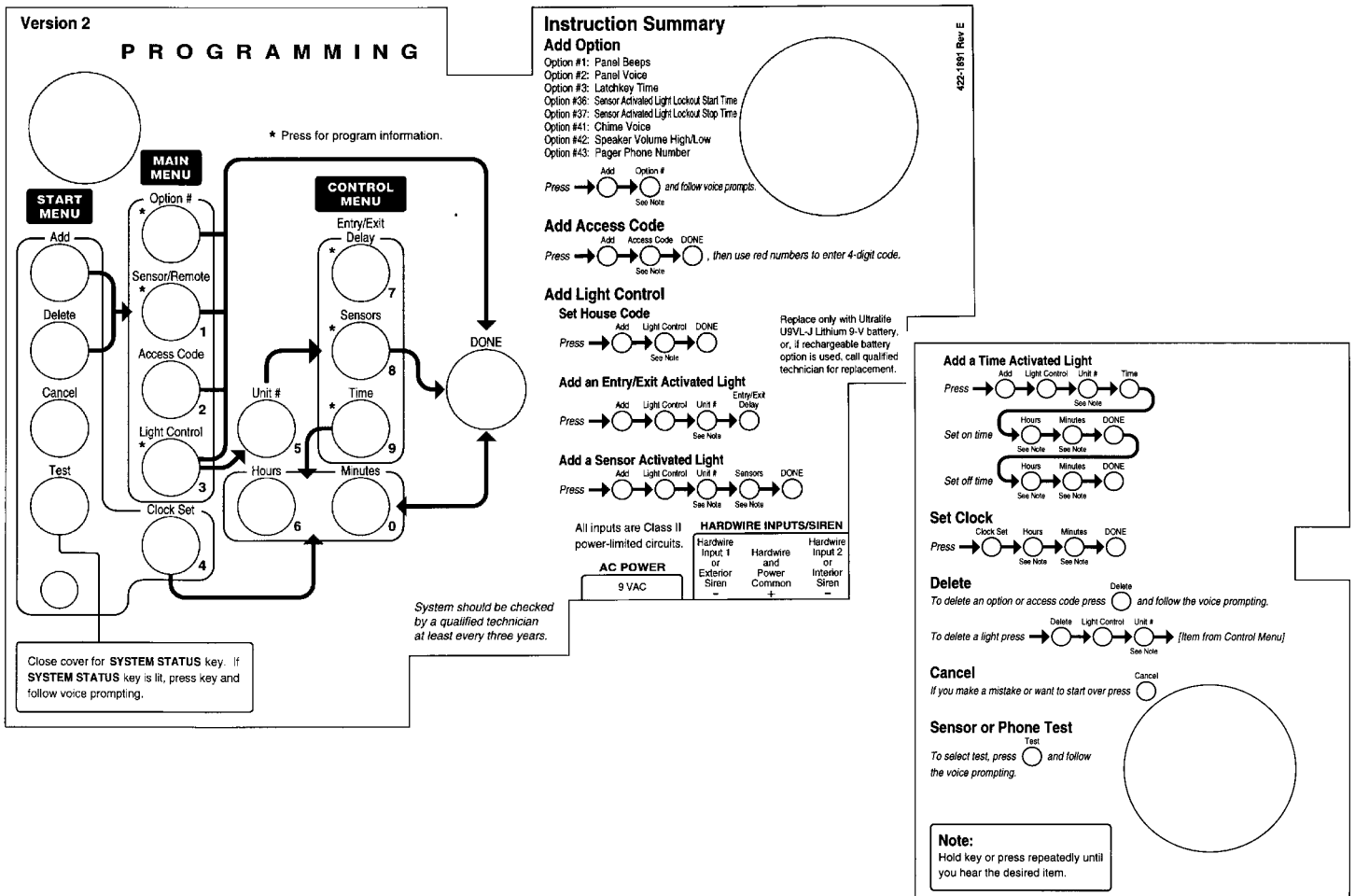

Programming Sensors

These instructions show you how to program sensors, touchpads and other system devices into the Control Panel.

Program sensors and devices before you install them. The Control Panel recognizes a sensor when you press the sensor’s program button or tamper switch.

Note: The hardwire inputs must have sirens, hardwire sensors, or 47k Ohm resistors connected between the positive and negative terminals before learning in a sensor. If one of these connections is not made, the panel will learn in a hardwire zone. See the section “Wiring the Control Panel” on page 21.

Note: If you are installing a sensor used with a gun case, jewelry box, or similar usage, and the sensor is active in level one, you must go into program mode to avoid putting the Control Panel into alarm when the sensor and the magnet are separated.

Table 19 describes the programming button location for each device.

Table 19 Device Programming

Device	To Program
Door/Window Sensor	Press button on top of sensor (cover removed)
Motion Sensor	Press button on back of sensor (mounting plate removed)
KeyChain Touchpad	Press lock & Unlock buttons
Remote Handheld Touchpad and Touchtalk 2-Way RF Touchpad*	Press the EMERGENCY buttons (to be used for non-medical emergencies)
Hardwire Sensors	Separate sensor from magnet
SWS*	Plug in the module
CO Alarm	Plug in the modules and within 30 seconds press the button for 6 beeps
Freeze & Water	Press the button on top of the sensor (cover removed) until the control panel confirms the programming. If the button is not held down long enough, SYSTEM STATUS will report the sensor is open.

Note: When installing crystal sensors, use the installation instructions included in their packing boxes. The appendix at the back of this document has instructions for the SAW sensors.

The Control Panel uses an ascending numbering sequence (beginning with 1) when adding (learning) sensors. You may override the system suggested sensor number by using the red numbered keys.

Use Table 1 on page 5, which was filled out during the system planning, to help program sensors.

To add a hardwire or RF sensor, SWS, or remote control:

Note: Do not program the SWS into the control panel until the house code has been programmed. See “Programming the House Code and Unit Numbers*” on page 26.

1. Press **Add** from the Start menu.
2. Press the **Sensor/Remote** button from the Main menu until you hear the room name or item you want to add. The order of names the Control Panel uses are: keychain remote, touchpad remote, front door, back door, garage door, bedroom, guest room, child’s room, utility room, living room, dining room, bathroom, laundry room, kitchen, office, den, garage, special chime, basement, upstairs, downstairs, hallway, medicine cabinet, closet, attic. Each name may be used more than once.

Note: When adding sensors, if you wish to use a more descriptive location you may press the option button to use the compass directions (north, north east, east, south east, south, south west, west, north west). This is especially useful when installing a system with a Touchtalk 2-Way RF Touchpad. The touchpad will not announce the sensor numbers when the system status is pressed. Instead of *Sensor 1 Bedroom Open* you will hear *Bedroom Sensor Open*. For example, if you have two bedrooms, name the sensors West Bedroom and East Bedroom. When status is pressed on the touchpad you will hear *West Bedroom Sensor Open*.

3. Press **DONE** when you hear the name you wish to add.
4. **Enter the 2 digit sensor type** using Table 1 on page 5, with the red numbered keys.

Note: If you wish to use a sensor number other than the next available, enter a 2 digit sensor number with the red numbered keys immediately after entering the sensor type.

5. **Press the sensor’s program button** or tamper button. Open the switch of hardwired sensors. See Table 19, “Device Programming” for more information. The Control Panel verbally confirms your programming.

* = Not Available with Basic Model

To delete sensors:

1. Press **Delete** from the Start menu.
2. Press **Sensor/Remote** from the Main menu until you hear the name you want to delete.
3. Press **DONE**. The system confirms the item you removed.

Programming the House Code and Unit Numbers*

Lamp Modules, Appliance Modules, Remote Sirens, and the SWS use the existing electrical wiring in the home to receive signals from the Control Panel. Since there are no direct wire connections required, any number of modules can be plugged into available outlets and installed in the system. All Lamp Modules and Appliance Modules have a common house code that allows modules to be identified by eight different control addresses.

The house code allows adjacent homes that have a common power source to co-exist. The available house code choices are from A to O.

To program the house code:

1. Press **Add** from the Start menu.
2. Press **Light Control** from the Main menu until you hear the house code letter you want.
3. Press **DONE**.
4. **Set the house code on each lamp and appliance module** using a screwdriver.
5. **Set house code on the remote siren** to the next alphabetical letter greater than the house code.

All Lamp Modules with the same house code will turn on or flash as a group on alarm or when operating the "Light" button on a KeyChain Touchpad. The units must be identified with a unique unit number, from 1-8, to individually operate lights and appliances from a Remote Handheld Touchpad or to selectively program lights to go on during the entry/exit delay, to be operated by a sensor or at scheduled times.

To assign a unit number:

1. See **Table 6 on page 9** for your planning information.
2. **Set the Unit number switch** on each module.

Programming Light and Appliance Controls*

Use Table 6 on page 9, which was filled out during the system planning, to help program control modules.

To add an entry/exit activated light:

1. Press **Add** from the Start menu.
2. Press **Light Control** from the Main menu.
3. Press **Unit #** until you hear the number you chose on the module.
4. Press **Entry/Exit Delay** from the Control menu. The Control Panel confirms your programming.

To add a sensor-activated light:

1. Press **Add** from the Start menu.
2. Press **Light Control** from the Main menu.
3. Press **Unit #** until you hear the number you chose on the module.
4. Press **Sensors** from the Control menu until you hear the sensor you want to control the light.
5. Press **DONE**. The Control Panel confirms your programming.

Note: A KeyChain Touchpad can be programmed to a unit number. Press the star button to activate a light or open/close a garage door using the Universal Module.

To add a time-activated light:

1. Press **Add** from the Start menu.
2. Press **Light Control** from the Main menu.
3. Press **Unit #** until you hear the unit number you chose on the module.
4. Press **Time** from the Control menu.
5. Press **Hours** and **Minutes** to set the beginning of the schedule.
6. Press **DONE**.
7. Press **Hours** and **Minutes** to set the end of the schedule.
8. Press **DONE**. The system confirms your programming.

To delete an Entry/Exit-activated light:

1. Press **Delete** from the Start menu.
2. Press **Light Control** from the Main menu.
3. Press **Unit #** until you hear the unit number you want to delete.
4. Press **Entry/Exit Delay**. The system confirms

your programming.

To delete a sensor-activated light:

1. Press **Delete** from the Start menu.
2. Press **Light Control** from the Main menu.
3. Press **Unit #** until you hear the unit number you want to delete.
4. Press **Sensors** from the control menu until you hear the one you want to delete.
5. Press **DONE**. The system confirms your programming.

To delete a time-activated light:

1. Press **Delete** from the Start menu.
2. Press **Light Control** from the Main menu.
3. Press **Unit #** until you hear the unit number you want to delete.
4. Press **Time** from the control menu.

Programming Options

Use Table 18 on page 19, which was filled out during the system planning, to help program options.

There are two ways to enter options. They are as follows:

- Press **Add** and press **the Option # button** until you hear the option to be changed.

or--

- Press **Add** and **enter the option number** you want to program with the red numbered keys.

The following instructions use the second method.

To set system options 01 and 02:

1. Press **Add** from the Start menu.
2. Press **Option #** and **01 or 02** with the red numbered keys.
3. Press **DONE**.

To set system option 03:

1. Press **Add** from the Start menu.
2. Press **Option # 03**.
3. Press **Hours** and **Minutes** to set the time.
4. Press **DONE**.

To set system options 04, 05, and 06:

1. Press **Add** from the Start menu.

2. Press **Option #** and **04, 05, or 06**.
3. **Enter a phone number** with the red numbered keys. Press **Test** to enter a pause in the phone number.

Note: The phone number is automatically stored after you've pressed 22 digits. You will not have to press **DONE** to store the number. If the number is less than 22 digits, then **DONE** must be pressed.

To set system option 07:

1. Press **Add** from the Start menu.
2. Press **Option # 07**.
3. **Enter the account number**.
4. Press **DONE**.

To set system option 08:

1. Press **Add** from the Start menu.
2. Press **Option # 08**.
3. Press **DONE**.

To set system option 09:

1. Press **Add** from the Start menu.
2. Press **Option # 09**.
3. **Enter the downloader code**.
4. Press **DONE**.

To set system options 10 & 11:

1. Press **Add** from the Start menu.
2. Press **Option # 10 or 11**.
3. **Enter the delay times** in seconds (3 digits must be entered).

To set system options 12 & 13:

1. Press **Add** from the Start menu.
2. Press **Option #** and **12 or 13**.
3. **Enter phone mod number**.

To set system option 14:

1. Press **Add** from the Start menu.
2. Press **Option # 14**.
3. Press **DONE**.

To set system option 15:

1. Press **Add** from the Start menu.
2. Press **Option # 15**.
3. **Enter the no activity time out** (2 digits must be entered).

To set system option 16:

1. Press **Add** from the Start menu.
2. Press **Option # 16**.
3. **Enter the number of days** between each auto

phone test (3 digits must be entered).

To set system option 17:

1. Press **Add** from the Start menu.
2. Press **Option # 17**.
3. **Enter the dialer delay** in seconds (3 digits must be entered).

To set system option 18:

1. Press **Add** from the Start menu.
2. Press **Option # 18**.
3. **Enter the alarm cancel time** in minutes (2 digits must be entered).

To set system option 19:

1. Press **Add** from the Start menu.
2. Press **Option # 19**.
3. **Enter the supervisory time** in hours (2 digits must be entered).

To set system options 20 - 26, 28 - 30, and 32:

1. Press **Add** from the Start menu.
2. Press **Option # XX**.
3. Press **DONE**.

To set system option 27:

1. Press **Add** from the Start menu.
2. Press **Option # 27**.
3. **Enter the ring/hang/ring number**.

To set system option 31:

1. Press **Add** from the Start menu.
2. Press **Option # 31**.
3. **Enter the day of week number**.

To set system option 33, 38, 40-42:

1. Press **Add** from the Start menu.
2. Press **Option # XX**.
3. Press **DONE**.

To set system options 34-37:

1. Press **Add** from the Start menu.
2. Press **Option # XX**.
3. Press **Hours** and **Minutes** to set the time.
4. Press **DONE**.

To set system option 39:

1. Press **Add** from the Start menu.
2. Press **Option # 39**.

3. Enter the minutes (2 digits must be entered).

To set system option 43:

1. Press **Add** from the Start menu.
2. Press **Option # 43**.
3. **Enter a phone number** with the red numbered keys. Press **Test** to enter a pause in the phone number.

Note: The phone number is automatically stored after you've pressed 22 digits. You will not have to press **DONE** to store the number. If the number is less than 22 digits, then **DONE** must be pressed.

To set system option 44:

1. Press **Add** from the Start menu.
2. Press **Option # 44**.
3. **Enter phone mod number**.

To set system option 45 - 53:

1. Press **Add** from the Start menu.
2. Press **Option # XX**.
3. Press **DONE**.

To delete options:

1. Press **Delete** from the Start menu.
2. Press **Option** from the Main menu until you hear the name you want to delete or use the red numbered keys to go directly to the option.
3. Press **DONE**. The system confirms the item you deleted.

Programming System Access Codes

Use Table 7 on page 10, which was filled out during the system planning, to program system Access Codes.

To add a code:

1. Press the **Add** button.
2. Press the **Access Code** button. Continue pressing the Access Code button until you hear the access code to be changed.
3. Press **DONE**.
4. **Enter the new access code** by using the red numbered keys.

The Control Panel says, *code name is XXXX* (the new 4 digit access code).

To delete a code:

1. Press **Delete** from the Start menu.
2. Press the **Access Code** button. Continue pressing the Access Code button until you hear the access code to be deleted.
3. Press **DONE**.

The Control Panel says, *code name is deleted*.

Installing the System

Control Panel General Information

Do not install the Control Panel near a window or door where it can be reached easily by an intruder.

Control Panels should be installed in locations where they are most likely to be heard.

Metal objects, mirrors, and metallic wallpaper can block signals sent by the wireless sensors. Make sure there are no metal objects in the way when installing the system.

The system will prompt you through programming steps with beeps and voice messages. If you need more time before proceeding, simply close the Control Panel cover until you are ready to continue.

When the cover is closed, the Control Panel is in the operating mode. Each time you close the Control Panel cover, a series of beeps (from the control panel pi-ezo, hardwire internal siren, SWS, and the X-10 powerhorn) will indicate the system status:

- One beep indicates the system is disarmed
- Two beeps verify that Door/Window sensors are armed.
- Three beeps verify that Motion Sensors are armed.
- Four beeps verify that both Door/Window and Motion sensors are armed.

Table 20 Arming Levels

Arming Level	Description of Level
0	Bypasses 24 hour intrusion sensors (Master Access Code Only)

Table 20 Arming Levels

Arming Level	Description of Level
1	Disarm the system
2	Arm Doors and Windows
3	Arm Motions
4	Arm Doors, Windows, and Motions

The system cannot work without power. If the electrical power fails and the Control Panel battery is weak or dead, the system will not work.

Control Panel Specifications

Power Requirements: 9 VAC, 700 mA

Non-Chargeable Backup Battery: 9 VDC 1.2 AH UltraLife Lithium. The battery will last 24 hours with no AC if fully charged. Typical Life of 1 year.

Rechargeable Backup Batteries:

1. 7.2 VDC, 1 Ah 5/3 AAA Nickel Metal Hydride
The battery will last 30 hours with no AC
2. 7.2 VDC, 580 mAh AAA Nickel Metal Hydride
The battery will last 16-18 hours with no AC

Radio Frequency: 319.5 MHz + or - 140 kHz

Nominal Range: 500 feet, open-air receiving range

Operating Temperature Range: 32°-122 ° F (0°-50° C)

Maximum Humidity: 85% relative humidity, non-condensing

Auxiliary Power Output: Regulated & unregulated, fused 12 VDC at 250 mA (maximum)

Installation Guidelines

Use the following procedure to mount the Control Panel to the wall or wall studs, using the supplied mounting hardware and the panel mounting holes.

Materials Needed

- Pencil
- Hammer

- Screwdriver

To mount the panel:

1. Choose a spot within a few feet of an electrical outlet (the outlet should not be controlled by a wall switch) and also within reach of a telephone jack. The Control Panel can be placed on a desk, tabletop, or it can be wall mounted.
2. Open the Control Panel cover and position on the wall.
3. Mark the screw hole locations with a pencil.
4. Start holes with the tip of the screwdriver or a nail.
5. Tap the wall anchors provided into the holes.
6. Insert the screws and partially tighten with the screwdriver.
7. Hang the Control Panel on the screws and tighten securely.
8. Remove the center screw from the outlet cover plate.
9. Position the transformer so that its screw hole is aligned with the screw hole on the outlet cover plate. Then plug the transformer into the outlet.
10. Replace the screw, and use it to secure the transformer to the outlet cover plate. Tighten the screw firmly with your screwdriver.

Sensor Installation

Use the installation instructions included with each sensor or if installing SAW sensors use document 466-1622, Booklet of Installation Instructions, attached to the back of this manual, for SAW Sensors.

Testing the Control Panel

Test the Control Panel by pressing the buttons as described below:

- ARM Doors & Windows-The Control Panel arms Doors & Windows. Press twice to eliminate the preprogrammed entry delay. The button will blink when No Entry Delay is on.
- ARM Motion Sensors-The Control Panel will arm Motion Sensors. Press twice to turn Latchkey on. The button blinks when Latchkey is on.
- DISARM -The Control Panel will disarm Doors,

Windows, and Motion Sensors when also entering the appropriate access code.

- SYSTEM STATUS-Press to determine system status and system time.
- CHIME Doors-Press to enable two beeps which will sound from the interior siren output, the panel siren, SWS, and the X-10 powerhorn siren (if set to unit number 9) when a protected door or window, that is programmed as sensor type 10 or 13, is opened.
- CHIME Special Motion- Press to enable three beeps which will sound from the interior siren output, the panel siren, SWS, and the X-10 powerhorn siren (if set to unit number 9) when a Motion Sensor, that is programmed as sensor type 25, is activated. If there are no sensors learned as type 25, this function will not be available. The control panel will also announce which sensor was tripped if chime voice (option 41) is on.
- LIGHTS Time Activated-Press to enable system controlled lights to turn on/off at a scheduled time.
- LIGHTS Sensor Activated-Press to enable system controlled lights to turn on for 4 minutes when a specific sensor is tripped.
- EMERGENCY-Press and hold or press twice quickly to activate a non-medical emergency alarm.

Testing the System

This section describes how to perform the following test procedures:

- Testing sensors
- Testing phone communication
- Testing central station communications
- Testing the X-10 Lamp Modules

You should test the system after installing, after servicing, and after adding or removing devices from the system.

Testing Sensors

We recommend that you test the sensors after all pro-

gramming is completed and whenever a sensor-related problem occurs.

Note: While the sensor test is a valuable installation and service tool, it only tests sensor operation for the current conditions. You should perform a sensor test after any change in environment, equipment, or programming.

1. **Place all sensors in their secured (non-alarm) state.**
2. **Open the Control Panel cover.**
3. **Enter the appropriate access code.**
4. Press **Test**.

The Control Panel responds with *Sensor test, press again to change or DONE to select.*

5. Press **DONE**.

Note: If the primary or secondary phone number (option 4 or 5) has been programmed, after pressing **Test** a second time, the Control Panel announces *Phone Test*. The phone testing procedure will be discussed later in this manual. After pressing **Test** a third time, the Control Panel announces *DL phone test*.

The Control Panel will prompt you to trip each sensor one at a time. You may follow the Control Panel's voice prompting or test the sensors in any order.

Interior sirens and speakers sound transmission beeps as each sensor is tripped. Each beep represents one RF packet.

Use the following table to trip sensors.

Sensor Tripping Instructions:

Sensor	Do This
Door/Window	Open the secured door or window
Freeze	Apply ice to the sensor. Do not allow the sensor to get wet
Water	Press a wet rag or wet finger over both of the round, gold-plated terminals on the underside of the sensor
Carbon Monoxide Alarm	Unplug the CO Alarm. Plug it back in, then press the TEST/RESET button until the unit beeps 8 times
Glass Guard	Tap the glass 3 or 4 inches from the sensor
Motion Sensor	Avoid the Motion Sensor's view for 5 minutes, then enter its view

Sensor Tripping Instructions:

Sensor	Do This
Rate-of-Rise Heat Detector	Rub your hands together until warm, then place one hand on the detector for 30 seconds
Shock	Tap the glass twice, away from the sensor. Wait at least 30 seconds before testing again
Smoke	Press and hold the test button until the system sounds transmission beeps
Panic Buttons	Press and hold the appropriate panic button(s) for 3 seconds
KeyChain Touchpad	Press and hold LOCK and UNLOCK simultaneously for 3 seconds
Remote Handheld Touchpad and Touchtalk 2-Way RF Touchpad*	Press and hold the 2 EMERGENCY buttons simultaneously for 3 seconds
SWS*	Unplug the SWS, plus the unit back in

6. **Count the number of transmission beeps** and refer to Table 21 on page 32 for minimum requirements. After the beeps, the Control Panel announces, *Sensor Name is activated, sensor status is XX (XX = number of RF packets)*. The system will continue to prompt for sensors which have not yet been tested. When all sensors have been tested the Control Panel will announce, *Sensor test complete, press DONE*.
7. Press **DONE**. The system will respond, *Sensor Test OK*.
8. If **Cancel** or **DONE** is pressed and the Control Panel has not heard from all sensors, the Control Panel will respond, *Sensor test canceled or failure*.

Note: If a sensor does not meet the minimum transmission beep requirements, refer to the If a Sensor Fails the Sensor Test section.

* = Not Available with Basic Model

Table 21 Minimum Transmission Beeps

Type of Sensor	Number of Beeps
Wireless Intrusion Sensors	7-8 beeps
Wireless Smoke & Heat Sensors	7-8 beeps
Wireless Environmental/Panic Buttons	7-8 beeps
Hardwire Loops	1
Emergency Buttons*	7-8 beeps

* The Control Panel Emergency Button cannot be tested.

If a Sensor Fails the Sensor Test

If sirens do not beep when a sensor is tripped, use an ITI RF Sniffer (60-401) test tool to verify that the sensor is transmitting. Constant beeps from the RF Sniffer indicate a runaway (faulty) sensor. Replace the sensor.

If possible, locate sensors within 100 feet of the panel. While a transmitter may have a range of 500 feet or more out in the open, the environment at the installation site can have a significant effect on transmitter range. Sometimes a change in sensor location can help overcome adverse wireless conditions.

To improve sensor communication, you can

- reposition the sensor
- relocate the sensor
- if necessary, replace the sensor

To reposition a sensor:

1. Rotate the sensor and test for improved sensor communication at 90 and 180 degrees from the original position.
2. If poor communication persists, relocate the sensor as described as follows.

To relocate a sensor:

1. Test the sensor a few inches from the original position.
2. Increase the distance from the original position and retest until an acceptable location is found.
3. Mount the sensor in the new location.
4. If no location is acceptable, replace the sensor.

To replace a sensor:

1. Test a known good sensor at the same location.
2. If the transmission beeps remain below the minimum level, avoid mounting a sensor at that location.
3. If the replacement sensor functions, contact ITI for repair or replacement of the problem sensor.

Testing Phone Communication

Perform a phone test to check the phone communication between the panel and the central station.

To perform a phone test/DL phone test:

1. **Open the Control Panel cover.**
2. **Enter the appropriate access code.**
3. Press **Test twice.**
4. Press **DONE.** The Control Panel responds with, *Phone test is on.* When the phone test is complete, the Control Panel will announce *Phone Test is OK* within 3 minutes. The Control Panel will say *Phone test is on* three times if you have a pager. Your pager will display 101 101 if the phone test to the pager was successful. If the test is unsuccessful, the **SYSTEM STATUS** button will light and the Control Panel will say *Phone communication failure* within 10 minutes.

If the panel announces *Phone communication failure*, proceed to the following instructions.

If the phone test fails:

1. Check that the panel is connected to the phone jack.
2. Check the phone number programmed into the panel.
3. Perform the phone test again.
4. If the phone test fails again, check the phone connection wiring.

Testing Central Station Communication

After performing sensor and phone tests, check that the system is reporting alarms successfully to the central station.

To test communication with the central station:

1. Call the central station and tell the operator that you will be testing the system.
2. Arm the system.
3. Test each of the wireless panic buttons and trip at least one sensor of each type—fire, intrusion, etc.—to verify that the appropriate alarms are working correctly.
4. When you finish testing the system, call the central station to verify that the alarms were received.

Testing the X-10 Lamp Modules*

Use Table 6 on page 9 to determine the full extent of module testing to be accomplished.

To test the system controlled lamp modules:

1. Press the **LIGHT** button on the KeyChain Touchpad repeatedly to turn all lights on and off. The Control Panel responds with *Lights on/off*.
2. Press the **Lights On** button and the **unit #** of the lamp module using the numeric buttons on the Remote Handheld Touchpad to test individual lamp modules, the Control Panel will respond with *Lights # on/off*.

Siren and X-10 Lamp Module Functions*

All sirens will time-out in the programmed siren time-out (1 - 254 minutes). Siren priority is as follows: fire, intrusion, then emergency. If an alarm of greater priority occurs during an alarm of lower priority, the higher priority alarm sirens sound. The X-10 must be set to unit #9 to hear emergency alarm beeps. Fire alarms will sound a temporal 3 pattern. Temporal 3 is 0.5 seconds on, 0.5 seconds off for 3 beeps then 1.5 seconds off.

Table 22 Alarm Siren and X-10 Light Information

	Fire	Intrusion	Emergency
X-10 Lights	Steady	Flashing	Steady
X-10 Siren	Steady	Steady	Alarm beeps
Interior & Panel Siren	Temporal 3	Steady	Fast on/off
Exterior Siren	Temporal 3	Steady	
SWS	Temporal 3	Steady	Fast on/off

Panel Tamper

If the system is armed and the cover is opened an intrusion alarm will sound and the system status will say *System Access Alarm* when the button is pressed.

* = Not Available with Basic Model

Troubleshooting

Use the following table to aid you with troubleshooting problems during installation.

Table 23 Troubleshooting Guide

Problem	Solution
<p><u>SYSTEM STATUS</u> How to clear SYSTEM STATUS (Alarm Memory)</p>	<p>From a disarmed state press SYSTEM STATUS twice, listen to the status message, then press DISARM.</p>
<p>SYSTEM STATUS says <i>Module 1 failure or Module 2 failure.</i></p>	<ul style="list-style-type: none"> • Turn option 53 off if a hardwire siren or sensor is not connected. • Check for the correct EOL resistor at Hardwire inputs 1 and 2. See “Connecting Hardwire Interior Sirens” on page 21.
<p>SYSTEM STATUS says <i>Low Battery.</i></p>	<p><u>UltraLife lithium battery</u></p> <ul style="list-style-type: none"> • Do a sensor test then check SYSTEM STATUS again. If the battery is still low, replace the battery. <p><u>Rechargeable Battery</u></p> <ul style="list-style-type: none"> • If the control panel has just been plugged in, the control panel will indicate a low battery until the battery is fully charged (9-12 hours). Make sure to turn option 49 on. • If the control panel has been powered for more than 12 hours, make sure option 49 is on.
<p>SYSTEM STATUS says <i>Option 50 Detected.</i></p>	<p>Option 50 is RF jam detect. The control panel has detected RF interference.</p>
<p>SYSTEM STATUS says that a sensor is open.</p>	<p>See Sensors section below.</p>
<p>SYSTEM STATUS says <i>System time is not set.</i></p>	<p>Set the system time.</p>
<p><u>Control Panel</u> The system says <i>Function not available</i> when Chime Doors is pressed.</p>	<p>No sensors are programmed using sensor type 10 or 13.</p>
<p>The system says <i>Function not available</i> when Chime Special Motion is pressed.*</p>	<p>No sensors are programmed using sensor type 25</p>
<p>The system says <i>Function not available</i> when LIGHTS Time Activated is pressed.*</p>	<p>No time activated lights have been programmed.</p>
<p>The system says <i>Function not available</i> when LIGHTS Sensor Activated is pressed.*</p>	<p>No sensor activated lights have been programmed.</p>
<p>The system says <i>Invalid. Sensor already programmed as Sensor Name.</i></p>	<p>This sensor is already programmed. Delete sensor if not correctly programmed.</p>
<p><u>Options (Programmable by the homeowner)</u> The Control Panel does not beep.</p>	<p>Program option 1 to be on.</p>
<p>Latchkey does not function.</p>	<ul style="list-style-type: none"> • Latchkey time (option 3) is not set. Set Latchkey time. • Latchkey is not enabled. Enable Latchkey by pressing ARM Motion Sensors twice. • The phone number is not programmed properly. Reprogram the phone number. (option 43) • System Time is not set. Set system time.
<p><u>Sensors</u> A sensor does not work.</p>	<ul style="list-style-type: none"> • Make sure the battery is fresh and installed correctly. • Check for interference from metal objects. Move or rotate the sensor. • Move the sensor to a new location.

* = Not Available with Basic Model

Table 23 Troubleshooting Guide

Problem	Solution
Door or window is closed, but the Control Panel voice says it is open.	<ul style="list-style-type: none"> • Be certain the arrow on the magnet and the guide line on the transmitter are aligned and are within 1/4' of each other. • The sensor tamper switch may be open if it is a crystal sensor.
Motion sensors go off continuously.	Be sure the sensor is mounted on a solid surface and the viewing field is free from sources of changing temperature.
Motion sensor does not respond to motion.	<ul style="list-style-type: none"> • Make sure the battery is fresh and installed correctly. Wait 2 minutes after installing a new battery to test the sensor. • Adjust the sensor mounting. • Leave the area for 3 minutes, then retest. • The environment is too hot or too cold. Outdoor sensors will operate between 32° and 120°F. • Dirt or dust may be causing the problem. Wipe the sensor with a clean, damp cloth.
<p><u>X-10 Modules*</u> All Lamp Modules or Siren not working.*</p>	<ul style="list-style-type: none"> • Be sure the Control Panel transformer is plugged directly into an outlet and that the outlet is not controlled by a wall switch. • Possibly a bad transformer. • House code was programmed incorrectly.
One Lamp Module or Siren is not working.*	<ul style="list-style-type: none"> • Unplug nearby equipment which may be causing interference (light dimmer switches, televisions, appliances with older motors). • Check that the switch on the lamp or appliance is turned on and remains on. • Make sure the lamp has a working bulb. • Make sure the lamp or appliance is plugged into the Lamp/ Appliance Module, the Module is plugged into the outlet and the outlet is not controlled by a wall switch. • Make sure the House and Unit Codes are correct. • Move the Module to a different outlet that is on the same phase (branch) of the household electrical circuit as the Control Panel.
Time activated or sensor activated light not working.*	<ul style="list-style-type: none"> • Make sure you have programmed the light to be activated by a timer or sensor. • Make sure the system clock is set. • Make sure these functions have been enabled by pressing the LIGHTS Time Activated/Sensor Activated on the Control Panel. They are enabled if the button is lit.

* = Not Available with Basic Model

Typical Backup Battery Life of the 9 Volt UltraLife

The following table and chart demonstrate backup battery life over time if the battery is tested every 4 hours (option 50 is off).

Table 24 Typical Backup Battery Life Cycle Over Time

Months in Use	Estimated Hours of Backup Power
0	30.159
1	27.861
2	25.562
3	23.264
4	20.966
5	18.668
6	16.370
7	14.072
8	11.774
9	9.475
10	7.177
11	4.879
12	2.581
13	0.283

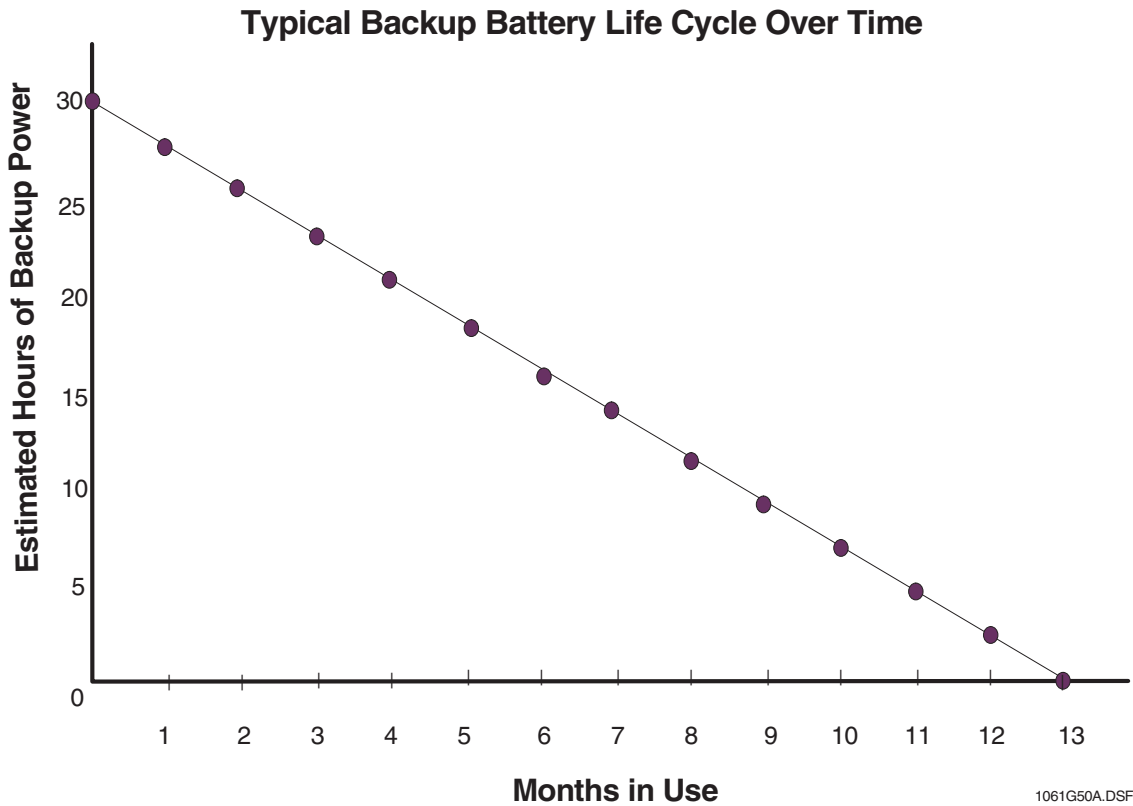

1061G50A.DSF

FCC Notices

FCC Part 15 Information to the User

Changes or modifications not expressly approved by GE Interlogix can void the user's authority to operate the equipment.

FCC Part 15 Class B

This equipment has been tested and found to comply with the limits for a Class B digital device, pursuant to part 15 of the FCC Rules. These limits are designed to provide reasonable protection against interference in a residential installation.

This equipment generates, uses, and can radiate radio frequency energy and, if not installed and used in accordance with the instructions, may cause harmful interference to radio communications. However, there is no guarantee that interference will not occur in a particular installation.

If this equipment does cause harmful interference to radio or television reception, which can be determined by turning the equipment off and on, the user is encouraged to try to correct the interference by one or more of the following measures:

- Reorient or relocate the receiving antenna.
- Increase the separation between the equipment and receiver.
- Connect the affected equipment and the panel receiver to separate outlets, on different branch circuits.
- Consult the dealer or an experienced radio/TV technician for help.

FCC ID: B4Z-787E-SIMON

ACTA Part 68

This equipment complies with Part 68 of the FCC Rules. Located on this equipment is a label that contains, among other information, the FCC registration number and the ringer equivalence number (REN) for this equipment. If requested, this information must be provided to the telephone company.

FCC Part 68 Registration No. B4ZUSA-27621-AL-E REN: 0.2B

The REN is used to determine the maximum number of devices that may be connected to your telephone line. Excessive RENs on a telephone line may result in devices not ringing in response to an incoming call. In most areas, the sum of all device RENs should not exceed five (5.0). To be certain of the number of devices that may be connected to a line, as determined by the total RENs, contact the local telephone company. For products approved after July 23, 2001, the REN for this product is part of the product identifier that has the format US:AAAEQ##TXXXX. The digits represented by ## are the REN without a decimal point (e.g., 03 is a REN of 0.3). For earlier products, the REN is separately shown on the label.

A plug and jack used to connect this equipment to the premises wiring and telephone network must comply with the applicable FCC Part 68 rules and requirements as adopted by ACTA. A compliant telephone cord and modular plug is provided with this product. It is designed to be connected to a compliant modular jack that is also compliant. See the Installation Instructions for details.

Alarm dialing equipment must be able to seize the telephone line and place a call in an emergency situation. It must be able to do this even if other equipment (telephone, answering system, computer modem, etc.) already has the telephone line in use. To do so, alarm dialing equipment must be connected to a properly installed RJ31X jack that is electrically in series and ahead of all other equipment attached to the same telephone line. Proper installation is depicted in the following diagram. If you have any questions concerning these instructions, consult your local telephone company or a qualified installer about installing an RJ31X jack and alarm dialing equipment for you.

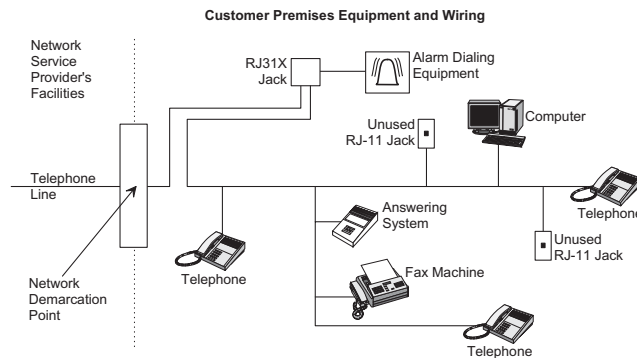

If this equipment causes harm to the telephone network, the telephone company may temporarily disconnect your service. If possible, you will be notified in advance. When advance notice is not practical, you will be notified as soon as possible. You will also be advised of your right to file a complaint with the FCC.

The telephone company may make changes in its facilities, equipment, operations, or procedures that could affect the operation of the equipment. You will be given advance notice in order to maintain uninterrupted service.

If you experience trouble with this equipment, please contact the company that installed the equipment for service and/or repair information. The telephone company may ask you to disconnect this equipment from the network until the problem has been corrected or you are sure that the equipment is not malfunctioning.

This equipment may not be used on coin service provided by the telephone company. Connection to party lines is subject to state tariffs.

Canada Notice

The Canadian Department of Communications label identifies certified equipment. This certification means that the equipment meets certain telecommunications network protective, operational, and safety requirements. The department does not guarantee the equipment will operate to the user's satisfaction.

Before installing this equipment, users should ensure that it is permissible to be connected to the facilities of the local telecommunications company. The equipment must also be installed using an acceptable method of connection. In some cases, the company's inside wiring associated with a single-line individual service may be extended by means of a certified connector assembly (telephone extension cord). The customer should be aware that compliance with the above conditions may not prevent degradation of service in some situations.

Repairs to certified equipment should be made by an authorized Canadian maintenance facility designated by the supplier. Any repairs or alterations made by the user to this equipment, or equipment malfunctions, may give the telecommunications company cause to request the user to disconnect the equipment.

For your protection, make sure that the electrical ground connections of the power utility, telephone lines, and internal metallic water pipe system, if present, are connected together



Do not attempt to make connections yourself. Contact the appropriate electrician or electric inspections authority.

The Load Number (LN) assigned to each terminal device denotes the percentage of the total load to be connected to a telephone loop which is used by the device, to prevent overloading. The termination on a loop may consist of any combination of devices subject only to the requirement that the total of the LNs of all the devices does not exceed 100. Load Number: .1 *The term "IC:" before the certification/registration number only signifies that the Industry Canada technical specifications were met.* IC: 867A 787SIMON

"AVIS: - L'étiquette du ministère des Communications du Canada identifie le matériel homologué. Cette étiquette certifie que le matériel est conforme à certaines normes de protection, d'exploitation et de sécurité des réseaux de télécommunications. Le ministère n'assure toutefois pas que le matériel fonctionnera à la satisfaction de l'utilisateur.

Avant d'installer ce matériel, l'utilisateur doit s'assurer qu'il est permis de le raccorder aux installations de l'entreprise locale de télécommunication. Le matériel doit également être installé en suivant une méthode acceptée de raccordement. Dans certains cas, les fils intérieurs de l'entreprise utilisés pour un service individuel à ligne unique peuvent être prolongés au moyen d'un dispositif homologué de raccordement (cordon prolongateur téléphonique interne). L'abonné ne doit pas oublier qu'il est possible que la conformité aux conditions énoncées ci-dessus n'empêche pas la dégradation du service dans certaines situations. Actuellement, les entreprises de télécommunication ne permettent pas que l'on raccorde leur matériel à des jacks d'abonné, sauf dans les cas précis prévus par les tarifs particuliers de ces entreprises.

Les réparations de matériel homologué doivent être effectuées par un centre d'entretien canadien autorisé désigné par le fournisseur. La compagnie de télécommunications peut demander à l'utilisateur de débrancher un appareil à la suite de réparations ou de modifications effectuées par l'utilisateur ou à cause de mauvais fonctionnement.

Pour sa propre protection, l'utilisateur doit s'assurer que tous les fils de mise à la terre de la source d'énergie électrique, des lignes téléphoniques et des canalisations d'eau métalliques, s'il y en a, sont raccordés ensemble. Cette précaution est particulièrement importante dans les régions rurales.

Avertissement. - L'utilisateur ne doit pas tenter de faire ces raccordements lui-même; il doit avoir recours à un service d'inspection des installations électriques, ou à un électricien, selon le cas".

Une note explicative sur les indices de charge (voir 1.6) et leur emploi, à l'intention des utilisateurs du matériel terminal, doit être incluse dans l'information qui accompagne le matériel homologué. La note pourrait être rédigée selon le modèle suivant:

"L'indice de charge (IC) assigné à chaque dispositif terminal indique, pour éviter toute surcharge, le pourcentage de la charge totale qui peut être raccordée à un circuit téléphonique bouclé utilisé par ce dispositif. La terminaison du circuit bouclé peut être constituée de n'importe quelle somme des indices de charge de l'ensemble des dispositifs ne dépassant pas 100."

L'Indice de charge de cet produit est _____.



































- Numerics
- 24 Hour Battery Test 22
- 2-Way Voice 17
- 2-way voice, on-board 4
- 300 Baud Central Station Communications 17, 22
- 319.5 Sensors 4
- A
- AC Power Failure 16
- AC Power Failure Report 21
- Access Code 12
- Access Code Programming 30
- Access Code, Master 12
- access code, master default 26
- Access Code, Panic Code 12
- Access Code, Utility 12
- access codes, utility defaults 26
- Account Number 13, 21
- activation method 10
- add hardwire/RF sensor, SWS, or remote control 27
- alarm 35
- Alarm Cancel 15
- Alarm Cancel Report 21
- appliance module 10
- Appliance Modules 4
- Arm Doors & Windows 9, 32
- Arm Doors/Windows 16
- Arm Doors/Windows & Motion Sensors 9
- Arm Doors/Windows and Motion Sensors 16
- ARM Doors/Windows with No Entry Delay 16
- Arm Doors/Windows with No Entry Delay and Motion Sensors with Latchkey 16
- Arm Motion Sensors 9, 16, 32
- Arm Motion Sensors with Latchkey 16
- arming levels 9
- Audio Verification 16, 22
- Audio Verification Mode 22
- Audio Verification Module 6
- Auto Arm 18, 22
- Auto Phone Test 15, 21
- Auxiliary Power Output 31
- AVM 4, 6
- AVM Fire Shutdown 19
- AVM Mode 19
- B
- Backup Battery Control Panel 31
- Backup Battery, Connecting 24, 25
- Backup Battery, Lithium 3
- Battery Pack, Nickel Metal Hydride 3
- battery test 24
- C
- Carbon Monoxide (CO) Alarm 4, 6
- CHIME Doors 18, 32
- CHIME Special Motion 18, 32
- Chime Voice 18, 22
- Closing Reports 15, 21
- CO Alarm 6
- CO Alarm Sensor Type 8
- Control Panel 4
- Control Panel Alarms 16
- Control Panel beeps 31
- Control Panel Specifications 31
- Control Panel, Wiring 23
- CPU Low Battery 16
- CPU Low Battery Report 21
- CS-5000 Receiver 5
- D
- Day of Week 17, 22
- Delays 9
- delete options 30
- delete sensors 28
- Dialer Delay 15, 21
- disarm 9, 16, 32
- DL Code (Downloader Code) 14
- Door Window Sensor program button 27
- Door/Window Sensor 3, 4, 5
- Downloader Code 21
- Downloader Phone Number 13, 21
- DTMF 21
- DTMF Dialing 14
- E
- EMERGENCY 32
- EMERGENCY buttons 27
- Emergency Planning Floor Plan 6
- Entry Delay 14, 21
- Entry/Exit activated light 28
- Entry/Exit-activated light 28
- Exit Delay 14, 21
- Exterior Door 8
- F
- Factory Defaults, reset memory to 23
- Fail to Close 17, 22
- Fail to Communicate 16, 21
- Fail to Open 17, 22
- Fire Shutdown - AVM 19, 22
- Floor Plan, Emergency 6
- Follower Delay 9

Force Arm 15
Forced Armed Report 21
Freeze Sensor 4, 8
G
Garage Door Modules 4
H
Hardwire Exterior Siren, Connecting 23
Hardwire Interior Sirens, Connecting 23
Hardwire Sensors program buttons 27
Hardwire Sensors, Connecting 23
High Level Status 22
HomeLink Transceiver 6
House Code 10
House Code and Unit Number programming 28
house code choices 28
I
improve sensor communication 34
Indoor Motion Sensor 5, 8
Indoor/Outdoor Motion Sensor 4
Installation Guidelines 31
Installing the Control Panel 31
Instant Delay 9
Interior Door 8
Interrogator AVM 4
Interrogator® 200 Audio Verification Module (AVM) 6
ITI CS-5000 Receiver 5
ITI HomeLink Transceiver (IHT) 6
ITI ToolBox 5
K
KeyChain Touchpad 3, 4, 5, 8
KeyChain Touchpad program buttons 27
KeyChain Touchpad programmed to a unit number 28
L
Lamp Modules 4
Lamp Modules house code 28
Latchkey 13, 21
LD105 Siren 23
learning sensors 27
LIGHTS Time or Sensor Activated 32
Lock & Unlock buttons 27
low battery 24
M
Manual Phone Test 15, 21
Maximum Humidity 31
Motion Activated Light Lock-Out Start Time 17
Motion Activated Light Lock-Out Stop Time 18
Motion Sensor Program Buttons 27
Motion Sensor, Indoor 5
Motion Sensor, Indoor/Outdoor 4
Motion Sensor, Outdoor 5
mount the panel 32
N
No Activity 15
No Activity Report 21
No Delay from KeyChain Touchpad 16, 22
Nominal Range 31
Non-rechargeable Battery, installation 24
Normal Battery Use 38
O
on-board 2-way voice 4
Opening Reports 15, 21
Operating Temperature Range 31
Option 01 Panel Piezo Beeps 12
Option 02 Panel Voice 12, 13
Option 03 Latchkey 13
Option 04 Primary Phone Number 13
Option 05 Secondary Phone Number 13
Option 06 Downloader Phone Number 13
Option 07 Account Number 13
Option 08 Phone Lock 13
Option 09 DL Code (Downloader Code) 14
Option 10 Entry Delay 14
Option 11 Exit Delay 14
Option 12 Phone Mod 1 14
Option 13 Phone Mod 2 14
Option 14 DTMF Dialing 14
Option 15 No Activity 15
Option 16 Auto Phone Test 15
Option 17 Dialer Delay 15
Option 18 Alarm Cancel 15
Option 19 Supervisory Time (SUPSYNC) 15
Option 20 Manual Phone Test 15
Option 21 Opening Reports 15
Option 22 Closing Reports 15
Option 23 Force Armed 15
Option 24 AC Power Failure 16
Option 25 CPU Low Battery 16
Option 26 Fail to Communicate 16
Option 27 Ring/Hang/Ring 16
Option 28 No Delay from KeyChain Touchpad 16
Option 29 Control Panel Alarms 16
Option 30 Panic Alarms 17
Option 31 Day of Week 17
Option 32 300 Baud 17
Option 33 2-Way Voice 17

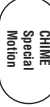
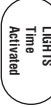
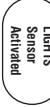
- Option 34 Fail to Open 17
- Option 35 Fail to Close 17
- Option 36 Motion Activated Light Lock-Out Start Time 17
- Option 37 Motion Activated Light Lock-Out Stop Time 18
- Option 38 Auto Arm 18
- Option 39 Siren Time Out 18
- Option 40 Trouble Beeps 18
- Option 41 Chime Voice 18
- Option 42 Speaker Level 18
- Option 43 Pager Phone Number 19
- Option 44 Pager Phone Mod 3 19
- Option 45 Sensor Alarm Restoral 19
- Option 46 Fire Shutdown - AVM 19
- Option 47 AVM Mode 19
- Option 48 Panic Talk 19
- Option 49 Rechargeable Battery 19
- Option 50 RF Jam Detect 19, 20
- Options Programming 29
- Options, System 12
- Outdoor Motion Sensor 4, 5, 8
- P
- Pager Phone Mod 3 19, 22
- Pager Phone Number 19, 22
- Panel Piezo Alarm 22
- Panel Piezo Beeps 12, 21
- Panel Piezo Beeps Table 13
- Panel Tamper 35
- Panel Voice 12, 13, 21
- Panic Alarms 17, 22
- Panic Talk 19
- Panic Talk - Audio Verification Mode 22
- Phone Button(s) 17
- Phone Line Connecting 25
- Phone Line to the Control Panel, Connecting 25
- Phone Lock 13, 21
- Phone Mod 1 14, 21
- Phone Mod 2 14, 21
- Planning Control Locations 10
- Planning Module Control 10
- Planning System Access Codes 12
- Power Requirements Control Panel 31
- Power Transformer 3
- Power Transformer, Connecting 24
- Powerhorn Siren house code 10
- Primary Phone Number 13, 21
- Program Buttons 27
- program mode 26
- program the house code 28
- Programming Access Codes 30
- Programming Light/ Appliance Controls 28
- Programming Options 29
- Programming Overview 26
- Programming the House Code and Unit Numbers 28
- R
- Radio Frequency Control Panel 31
- range 34
- Receiver, CS-5000 5
- Rechargeable Battery 19, 22, 31
- Rechargeable Battery, Connecting 25
- Recommended Sensor Types 8
- relocate a sensor 34
- Remote Access 16
- Remote Handheld Touchpad 4, 5, 8
- Remote Handheld Touchpad program buttons 27
- remote siren house code 28
- Remote Siren house code, unit number 10
- Remote Siren, Powerhorn 4
- replace a sensor 34
- reposition a sensor 34
- Reset Memory to the Factory Defaults 23
- RF Jam Detect 19, 20, 22
- RF Sniffer 34
- Ring/Hang/Ring 16, 21
- RJ-31X Jack, Installing 25
- S
- Secondary Phone Number 13, 21
- Sensor Activated Light Lockout Start Time 22
- Sensor Activated Light Lockout Stop Time 22
- Sensor Alarm Restoral 19, 22
- Sensor Fails Sensor Test 34
- sensor learning 27
- Sensor Tripping Instructions 33
- Sensor Type Characteristics 9
- sensor, 24-hour 34
- sensor, deleting 28
- sensor, hardwire loop 34
- Sensor/Device Location Planning Table 7
- sensor-activated light 28, 29
- Siren and X-10 Lamp Module Functions 35
- Siren Time Out 18, 22
- Siren, LD105 23
- Smoke Sensor 3, 5, 8
- Smoke Sensor, Wireless 3
- Speaker Level 18, 22
- Special Installation Requirements 3

Specifications Control Panel 31
Standard Delay 9
Status, System 16
Subdisarm 9
subdisarm 12
Supervised Wireless Siren (SWS) 6
Supervisory Time (SUPSYNC) 15, 21
SUPSYNC 3
SWS 4, 6
SWS programming 27
SWS Sensor Type 8
SWS, Supervised Wireless Siren 6
System Options 12
System Status 16, 24, 32
System, Basic 3
T
Table Access Codes 12
Table Alarm Siren and X-10 Light Information 35
Table Arming Levels 31
Table Audio Verification Set 17
Table Day of Week by Number 17
Table Device Programming 27
Table Home Control Planning 11
Table House Code Assignments 11
Table Minimum Transmission Beeps 34
Table Opening/Closing Reports User Codes 15
Table Pager Phone Mod Format 19
Table Pager Reporting Message 19
Table Panel Piezo Beeps 13
Table Phone Commands for Remote Access 16
Table Phone Mod 1 14
Table Phone Mod 2 14
Table Programmable Options 21
Table Recommended Sensor Types 8
Table Ring/Hang/Ring Program Numbers 16
Table Sensor Tripping Instructions 33
Table Sensor Type Characteristic 9
Table Sensor/Device Location Planning 7
Table Troubleshooting Guide 36
Table Unit Number Assignments 11
Table User Codes for OpeningClosing Reports 15
Tamper alarm 35
tamper button 27
Testing Phone Communication 34
Testing the System 32
Testing the X-10 Lamp Modules 35
time-activated light 28, 29
Toggle Lights 16
ToolBox, ITI 5
Touchpad, 2-Way RF Touchtalk 4
Touchpad, KeyChain 4, 5
Touchpad, Remote Handheld 4, 5
Touchpad, Touchtalk 2-Way RF 5
Touchtalk 2-Way RF Touchpad 4, 5, 8
Touchtalk 2-Way RF Touchpad program buttons 27
Trouble Beeps 22
Trouble beeps 18
U
UL 1023 3
ULC-S545-M89 3
UL-Listed Installation Requirements 3
Unit Number 10
Universal Module 10
Universal/Garage Door Modules 4
Universal/Garage Door Opener Module, Connecting 24
User Codes for Opening/Closing Reports Table 15
W
Wall Switch Modules 4
Water Sensor 4, 8
Window Sensor 8
Wiring the Control Panel 23
X
X-10 Appliance Module 4
X-10 Lamp Module and Siren Functions 35
X-10 Lamp Modules 4
X-10 Powerhorn/Remote Siren Modules 4
X-10 Universal/Garage Door Modules 4
X-10 Wall Switch Modules 4

Quick Reference Table

How to . . .	CONTROL PANEL	REMOTE HANDHELD & Touchaik 2-Way RF TOUCHPAD	KEYCHAIN TOUCHPAD	REMOTE PHONE CONTROL
Arm the system – Doors & Windows				Press * + Master Code + 2
Arm the system – Motion Sensors				Press * + Master Code + 3
Arm the system – Doors/Windows & Motion Sensors	 	 		Press * + Master Code + 2 + 3
Activate No Entry Delay				Press * + Master Code + 2 + 2
Activate the Latchkey feature				Press * + Master Code + 3 + 3
Disarm the system				Press * + Master Code + 1
Subdisarm the system	Master Code	Master Code		Press * + Master Code + 1
Send an alarm to the Central Monitoring Station		  Press both EMERGENCY buttons. Press & hold for 3 seconds.	  Press & hold for 3 seconds	
Check the system status				Press * + Master Code + # + 1
Set doors to Chime				
Set Special Motion Chime				
Set lights to time activated				
Set lights to sensor activated				
Open a garage door or turn on special lights		 + Unit #		
Toggle lights				Press * + Master Code + 0
	