

TVP-CB1 Compact PTZ Cup Base Installation Instructions

Specifications

Dimensions:

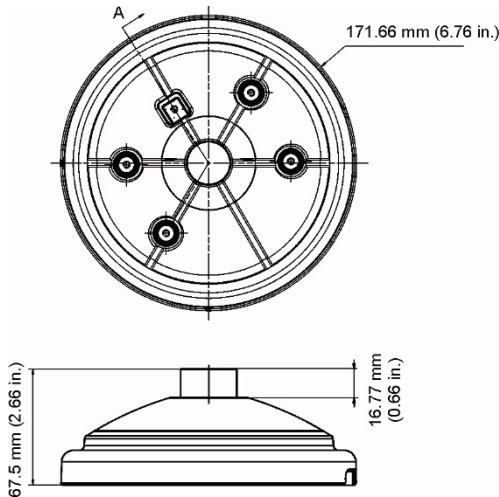

Weight: 310 g (0.68 lbs.)

Accessories:

Screw A: 4 pcs

Used to install the mounting plate to the TVP-CB1 cup base.

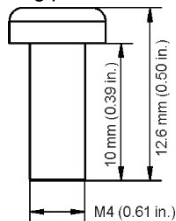

Supported devices

The compact PTZ cup base can be used with the following devices:

IP Compact PTZ Camera:	TVP-5103
Cup Base Wall Mount:	TVD-CBW
Swan Neck Wall Mount:	TVD-SNB
Pendant Mount:	TVD-PPB

Installation

To install the TVP-5103 PTZ camera to a TVD-CBW wall mount with a TVP-CB1 cup base:

1. Screw the cup base onto the wall mount, Secure the cup base with a locking screw.

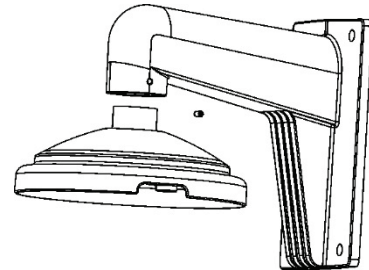

2. Using the Torx wrench that is supplied with the PTZ, loosen the Torx screw at the base of the PTZ. Loosen slightly the three screws/standoffs on the base of the PTZ camera and rotate the metal adapter plate counterclockwise to separate it from the PTZ camera.

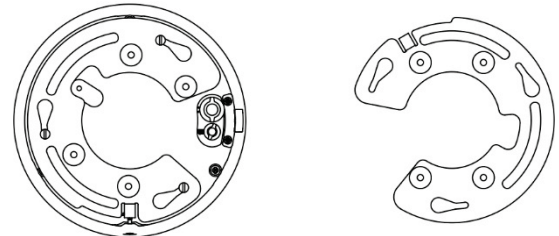

3. Place the metal PTZ adapter plate on the cup base. The arrow that states FRONT should be pointing away from the base of the wall mount. Using screw A, secure the adapter plate to the cup base. Tighten screw A fully. Otherwise, the dome will not slide properly into place over the three standoffs, and the screw head will block the rotation.

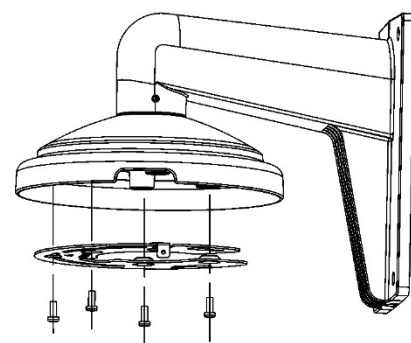

4. Use the wall mount base to mark the holes for the expansion anchors and to also provide access for the cable harness prior to installing with the mount.

- Secure the wall mount to the mounting surface using the expansion anchors that are provided with the wall mount.

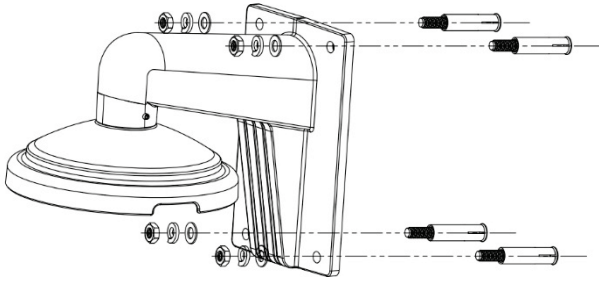

- Attach the safety lanyard to the base of the PTZ camera, as shown. It is important to make sure that the lug, at the end of the safety lanyard, is contained within the recessed area of the PTZ base, otherwise it will not allow you to lock the PTZ to the adapter plate.

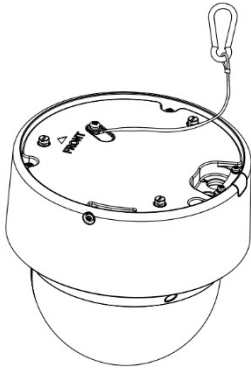

- Clip the safety lanyard on the metal tab inside of the cup base wall mount, as shown.

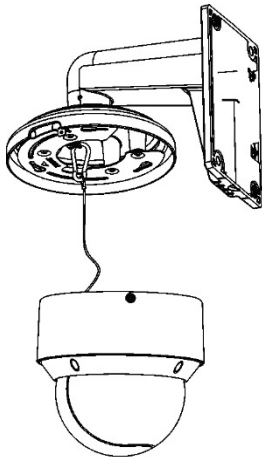

- Route the PTZ cable harness through the cup base. If you are not using all the features/cables, you may want to tuck them behind the PTZ adapter plate to keep them out of the way so they do not interfere when installing the PTZ on the cup base.
- Align the PTZ camera with the standoffs on the mounting plate. Rotate the PTZ camera clockwise on the mounting plate to lock the assembly in place, making sure that the Torx screw is lined up with the metal tab on the metal adapter plate.

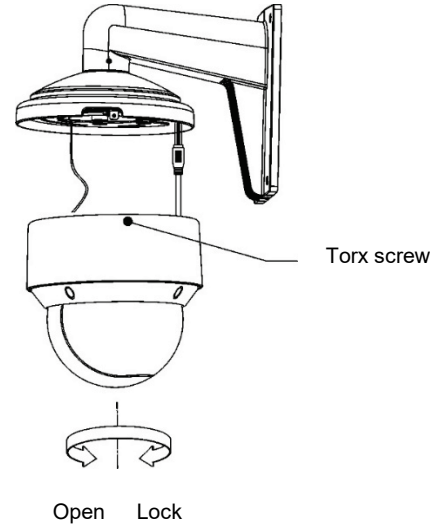

- Tighten the Torx screw at the base of the PTZ to lock into place.

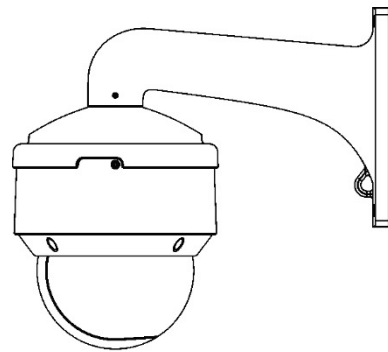

To install the TVP-5103 PTZ camera to a TVD-PPB pendent mount with a TVP-CB1 cup base:

- Screw the cup base onto the pendent mount tube. Secure the cup base with a locking screw.

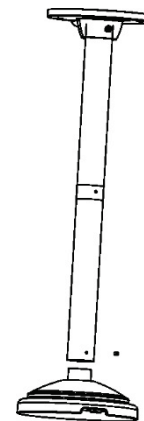

- Using the Torx wrench that is supplied with the PTZ, loosen the Torx screw at the base of the PTZ. Loosen slightly the three screws/standoffs on the base of the PTZ camera and rotate the metal adapter plate counterclockwise to separate it from the PTZ camera.

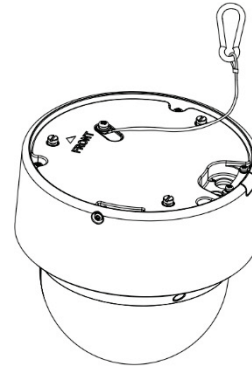
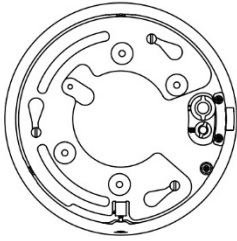

- Place the metal PTZ adapter plate on the cup base. The arrow that states FRONT should be pointing away from the base of the cup base. Using screw A, secure the adapter plate to the cup base. Tighten screw A fully, otherwise the dome will not slide properly into place over the three standoffs and the screw head will block the rotation.

- Clip the safety lanyard on the metal tab inside of the cup base, as shown.

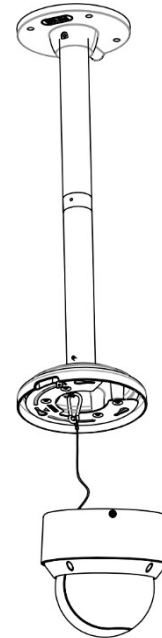
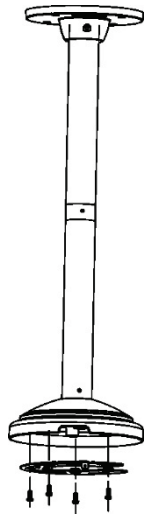

- Route the camera interconnect cables through the pendent mount. Attach the mount to the ceiling using the expansion anchors that are included with the pendent mount.

- Route the PTZ cable harness through the cup base. If you are not using all the features/cables, you may want to tuck them behind the PTZ adapter plate to keep them out of the way so they do not interfere when installing the PTZ on the cup base.
- Align the PTZ camera with the standoffs on the mounting plate. Rotate the PTZ camera clockwise on the mounting plate to lock the assembly in place, making sure that the Torx screw is lined up with the metal tab on the metal adapter plate.

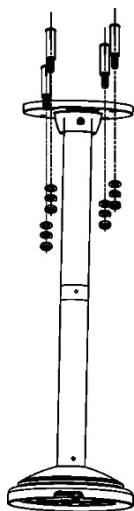

- Attach the safety lanyard to the base of the PTZ camera, as shown. It is important to make sure that the lug, at the end of the safety lanyard, is contained within the recessed area of the PTZ base, otherwise it will not allow you to lock the PTZ to the adapter plate.

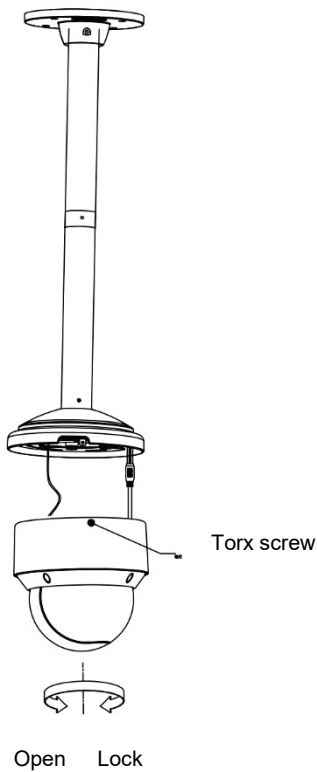

9. Tighten the Torx screw at the base of the PTZ to lock into place.

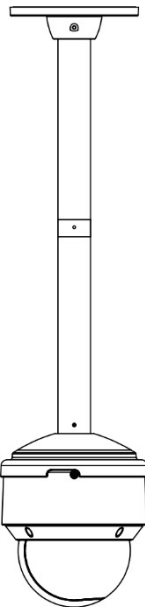

To install the TVP-5103 PTZ camera to a TVD-SNB wall mount with a TVD-CB1 cup base:

1. Route the camera cables through the wall mount. Attach the swan neck mount to the wall using the expansion anchors that are provided with the mount. Screw the cup base onto the wall mount.

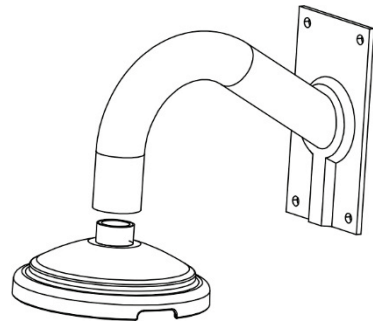

2. Using the Torx wrench that is supplied with the PTZ, loosen the Torx screw at the base of the PTZ. Loosen slightly the three screws/standoffs on the base of the PTZ camera and rotate the metal adapter plate counterclockwise to separate it from the PTZ camera.

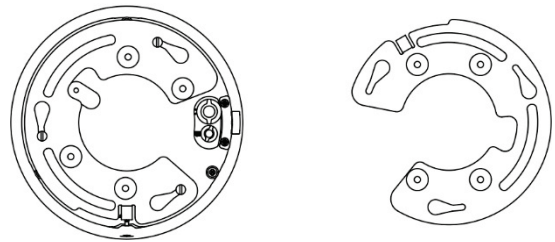

3. Place the metal PTZ adapter plate on the cup base. The arrow that states FRONT should be pointing away from the cup base. Using screw A, secure the adapter plate to the cup base. Tighten screw A fully, otherwise the dome will not slide properly into place over the three standoffs and the screw head will block the rotation.

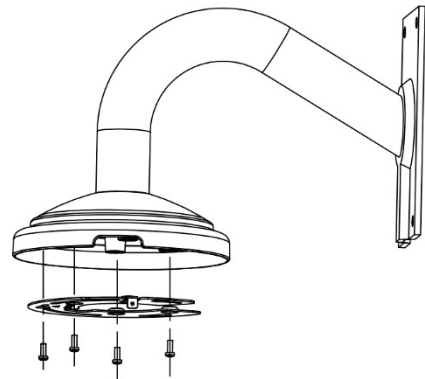

4. Use the wall mount base to mark the holes for the expansion anchors and to also provide access for the cable harness prior to installing with the mount.
5. Secure the wall mount to the mounting surface using the expansion anchors that are provided with the wall mount.

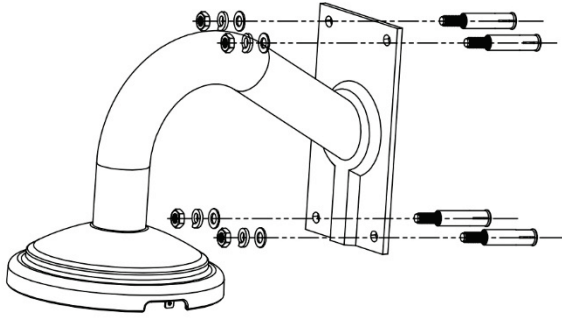

- Attach the safety lanyard to the base of the PTZ camera, as shown. It is important to make sure that the lug, at the end of the safety lanyard, is contained within the recessed area of the PTZ base, otherwise it will not allow you to lock the PTZ to the adapter plate.

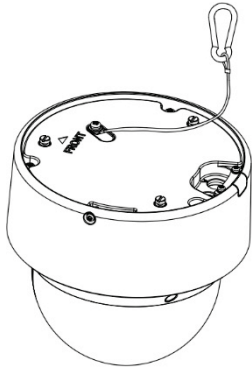

- Clip the safety lanyard on the metal tab inside of the cup base, as shown.

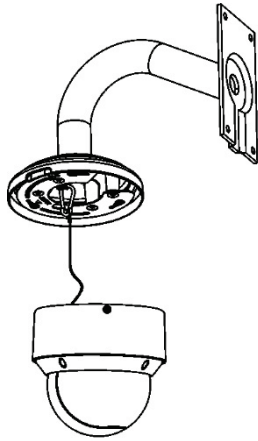

- Route the PTZ cable harness through the cup base. If you are not using all the features/cables, you may want to tuck them behind the PTZ adapter plate to keep them out of the way so they do not interfere when installing the PTZ on the cup base.
- Align the PTZ camera with the standoffs on the mounting plate. Rotate the PTZ camera clockwise on the mounting plate to lock the assembly in place, making sure that the Torx screw is lined up with the metal tab on the metal adapter plate.

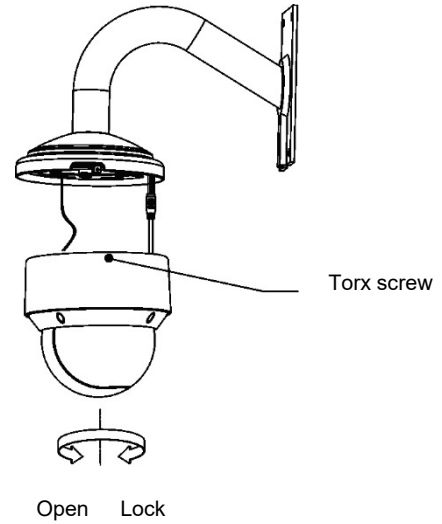

- Tighten the Torx screw at the base of the PTZ to lock into place.

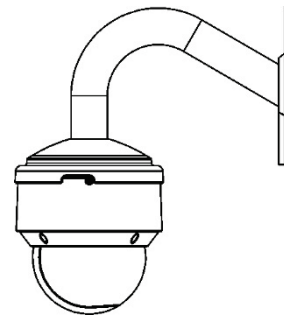

Legal and regulatory information

Copyright	© 2018 United Technologies Corporation. Interlogix is part of UTC Climate, Controls & Security, a unit of United Technologies Corporation. All rights reserved.
Trademarks and patents	The trade names used in this document may be trademarks or registered trademarks of the manufacturers or vendors of the respective products.
Disclaimer	Information in this document is subject to change without notice. No part of this document may be reproduced or transmitted in any form or by any means, electronic or mechanical, for any purpose, without the express written permission of UTC Fire & Security Americas Corporation, Inc.
Manufacturer	Interlogix. 2955 Red Hill Avenue, Costa Mesa, CA 92626 5923, USA Authorized EU manufacturing representative: UTC Fire & Security B.V. Kelvinstraat 7, 6003 DH Weert, The Netherlands
Certification	 

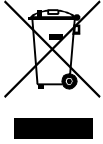

2012/19/EU (WEEE directive): Products marked with this symbol cannot be disposed of as unsorted municipal waste in the European Union. For proper recycling, return this product to your local supplier upon the purchase of equivalent new equipment, or dispose of it at designated collection points. For more information see: www.recyclethis.info.

Product warnings and disclaimers

THESE PRODUCTS ARE INTENDED FOR SALE TO AND INSTALLATION BY QUALIFIED PROFESSIONALS. UTC FIRE & SECURITY CANNOT PROVIDE ANY ASSURANCE THAT ANY PERSON OR ENTITY BUYING ITS PRODUCTS, INCLUDING ANY "AUTHORIZED DEALER" OR "AUTHORIZED RESELLER", IS PROPERLY TRAINED OR EXPERIENCED TO CORRECTLY INSTALL FIRE AND SECURITY RELATED PRODUCTS.

For more information on warranty disclaimers and product safety information, please check www.firesecurityproducts.com/policy/product-warning/ or scan the following code:



Contact information and manuals/ tools/ firmware

For contact information and to download the latest manuals, tools, and firmware, go to the web site of your region.

Americas: www.interlogix.com

EMEA: www.firesecurityproducts.com

Manuals are available in several languages.

Australia/New Zealand: www.utcfs.com.au
