



TruVision TVB-2104/4104 and TVB-2105/4105 IR Camera User Manual

Copyright	© 2013 UTC Fire & Security. All rights reserved.
Trademarks and patents	The TruVision and Interlogix names and logo are trademarks of UTC Fire & Security. Other trade names used in this document may be trademarks or registered trademarks of the manufacturers or vendors of the respective products.
Manufacturer	UTC Fire & Security Americas Corporation, Inc. 2955 Red Hill Avenue, Costa Mesa, CA 92626-5923, USA Authorized EU manufacturing representative: UTC Fire & Security B.V. Kelvinstraat 7, 6003 DH Weert, The Netherlands
Certification	  N4131
FCC compliance	Class A: This equipment has been tested and found to comply with the limits for a Class A digital device, pursuant to part 15 of the FCC Rules. These limits are designed to provide reasonable protection against harmful interference when the equipment is operated in a commercial environment. This equipment generates, uses, and can radiate radio frequency energy and, if not installed and used in accordance with the instruction manual, may cause harmful interference to radio communications. Operation of this equipment in a residential area is likely to cause harmful interference in which case the user will be required to correct the interference at his own expense.
ACMA compliance	Notice! This is a Class A product. In a domestic environment this product may cause radio interference in which case the user may be required to take adequate measures.
European Union directives	12004/108/EC (EMC directive): Hereby, UTC Fire & Security declares that this device is in compliance or with the essential requirements and other relevant provisions of Directive 2004/108/EC 2002/96/EC (WEEE directive): Products marked with this symbol cannot be disposed of as unsorted municipal waste in the European Union. For proper recycling, return this product to your local supplier upon the purchase of equivalent new equipment, or dispose of it at designated collection points. For more information see: www.recyclethis.info .
Contact information	For contact information, see www.utcfireandsecurity.com or www.utcfssecurityproducts.eu .



Content

Product overview	2
Package contents	2
Features	2
User guidelines	2
Product description	3
Installation	4
Mount the camera	4
Connect the cables	5
Adjust the focus and zoom	5
Programming	5
Access the Main menu	6
Exposure	7
Backlight	8
Day/Night mode	10
Image noise reduction	11
Defog	12
Function menus	13
Privacy mask area	14
Digital effect	15
Image adjustment	17
Protocol adjustment	18
Autofocus	20
OSD language	21
Exit menu	21
Specifications	21
Menu Tree	22

Product overview

The TVB-2104/4104 and TVB-2105/4105 camera uses a digital signal processor (DSP) to process video signals. The camera includes a microcontroller to provide high-quality images with high-color reproduction and sharp pictures.

Package contents

The package contains the following:

- Camera
- Monitor output cable
- Mounting screws, wall anchors, and hex wrench
- Power terminal
- Ceiling drilling holes template

Note: Use the video output BNC and power jack for normal system operation. Use the monitor output cable for installation and maintenance.

Features

The camera includes the following features:

- Exview HAD II (hole accumulated diode) technology with 480,000 pixels NTSC (570,000 PAL)
- Use of LSI (large scale integration) digital processors to produce 700 lines of horizontal resolution
- Motorized lens with auto and manual focus for easy installation
- Advanced OSD (onscreen display) control via DVR with Coaxial Control feature
- Advanced privacy mask areas to protect privacy concerns
- Digital WDR (wide dynamic range)
- Long life and high reliability
- Isolated switching power 12 VDC and 24 VAC

User guidelines

- Program the camera settings as much as possible before mounting the camera. Take appropriate safety precautions while completing programming after installation.
- Always use a 12 VDC or 24 VAC UL listed Class 2 power supply to power the camera.

- Do not use the camera over the temperature range specifications: -30 to +60°C (-22 to +122°F)
- If the light source where the camera is installed experiences rapid, wide-variations in lighting, the camera may not operate as intended.

WARNING: To reduce the risk of fire or electronic shock, do not expose the camera to rain or moisture and do not remove the cover or back.

Product description

The camera consists of the following:

- Camera with power and video output cables
- Sunshield
- Drilling-hole template
- One dual-power terminal block with its screw and anchor
- Four anchors and four screws for wall or ceiling installation

Refer to the following figures when performing the camera setup procedures.

Figure 1: Parts of the camera

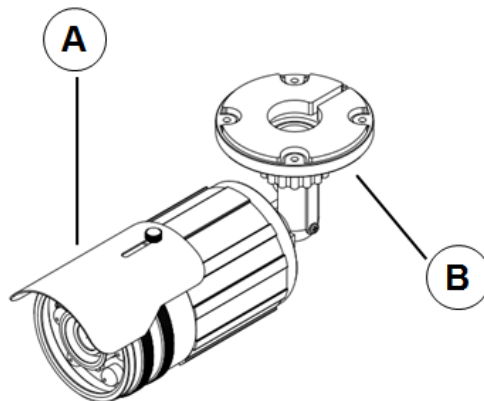

A; Sunshield; B. Hidden cable bracket

Figure 2: Camera lens, IR LEDs, and light

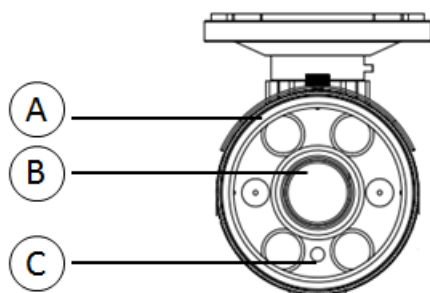

A. LED IR light (total number of lights varies by model)

B. Lens

C. Light sensor

Figure 3: OSD control cable

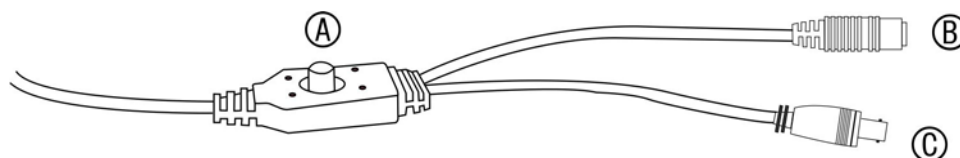

A. OSD control pad; B. Power cable; C. Video cable

Table 1: OSD control pad functions

Pad directions	Description
Up	Zoom-in lens or move the cursor upward to select an item.
Down	Zoom-out lens or move the cursor downward to select an item.
Right	Adjust the lens focus to far or move the cursor to the right to select or adjust the options of the selected item.
Left	Adjust the lens focus to near or move the cursor left to select or adjust the options of the selected item.
Enter	Press the center of the control pad to display the Main menu. If the selected item has its own menu, press the control pad to enter a submenu. Press the control pad for 2 seconds to save all settings and exit the Main menu.

Installation

Please check the package contents and make sure that the device in the package is in good condition and all the assembly parts are included.

To install the camera you will need to prepare the mounting surface, mount the camera, make cable connections, adjust the lens and then configure the camera settings.

Note: Before installing, please ensure that the mounting surface is strong enough to withstand three times the weight of the camera. If the mounting surface is not strong enough, the camera may fall and cause serious damage.

Mount the camera

1. When installing the TVB-2104/TVB-4104 and TVB-2105/TVB4105 camera, please use the attached mount
2. Using the mount as a template, place it level against the mounting surface and mark the position of the mounting holes.
3. Following all local codes, drill and prepare the mounting holes.
4. Securely fasten the mount to the mounting surface with the appropriate fasteners.

Connect the cables

To connect the cables:

1. Connect a coaxial cable from the camera's BNC connector to a CCTV monitor or video recording device.
2. Connect the 12 VDC or 24 VAC power supply to the power jack of the camera.

Caution: Check for polarity when using a 12 VDC power supply.

Note: Please check the specification table on page 21 for the power consumption of the camera. We suggest the use of a 2A power supply for the camera.

Adjust the focus and zoom

Figure 4: Zoom and focus adjustment

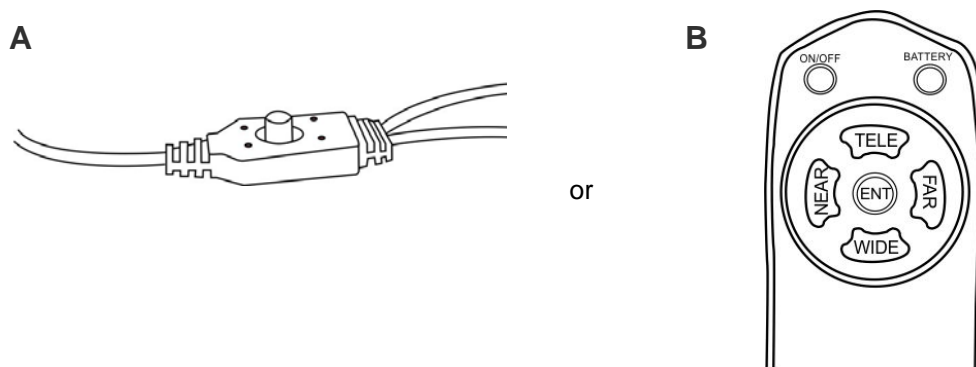

To adjust the camera zoom and focus:

1. Use the OSD control pad (A) or the coaxial controller (B) to adjust the camera zoom and focus. See Figure 4.

TELE (Up) – Zoom in the lens

WIDE (Down) – Zoom out the lens

FAR (Right) - Adjust the lens focus

NEAR (Left) - Adjust the lens focus

Programming

Once the camera hardware has been installed, the camera can then be configured.

Before using the OSD to configure the camera, ensure that the camera focal length and focus are correctly adjusted.

Access the Main menu

The Main menu provides access to the camera configuration options. The on-screen display (OSD) is only available in multi languages, such as English, Korean, Traditional Chinese, Simplified Chinese, Japanese, Russian, French, Spanish, Italian, Portuguese, Dutch, German, Polish, Turkish, Hebrew, Arabic.

Program the camera by attaching a standard video monitor to the system.

Figure 5: The Main menu

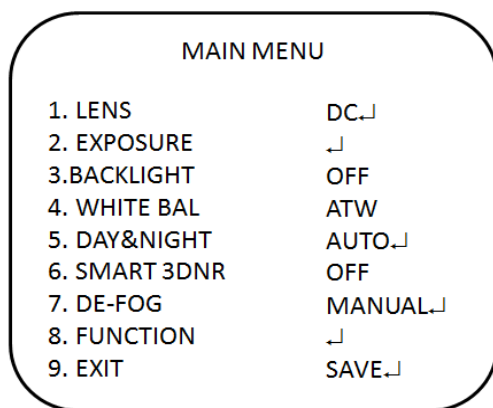

Table 2: Main menu description

Menu item	Description
Lens	Defines the lens brightness and iris speed.
Exposure	Defines the method of iris control.
Backlight	Defines the highlight compensation (HLC) and backlight compensation (BLC) set up.
White bal	Defines the white balance (WB) set up
Day&night	Defines the day/night (D/N) set up
Smart 3DNR	Defines the digital noise reduction set up
De-fog	Defines the defog set up
Function	Defines motion detection, privacy, digital effect, image adjustment, autofocus, language and OSD color set up
Exit	Exits the menu and returns to live mode. Saves changes made.

To access the Main menu:

1. Press the OSD control pad (**Enter**) or Coaxial Control Enter button to access the Main menu and its submenus.
2. Push the pad up, down, left and right or Coaxial Control TELE, WIDE, NEAR, and FAR button to move between menu options.
3. Press the OSD control pad Coaxial Control Enter button to select an option.
4. When in a sub menu, select **Return** to return to the previous menu.
5. To exit the Main menu, move the cursor to **Exit** at the bottom of the screen and press **Enter**. All changes are saved.

Select the lens

In the Main menu, go to **Lens** and select the type of lens used with the camera. Select **DC** to adjust the lens setting manually,

DC Lens menu:

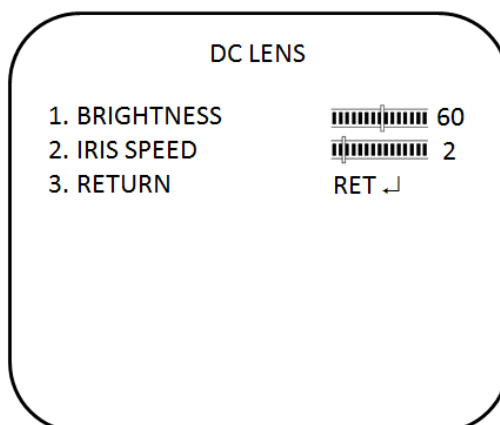

Brightness: Select the Brightness level, value from 1 to 100.

Iris Speed: Select the iris speed, value from 1 and 5.

Exposure

In the Main menu, go to **Exposure** and press Enter. The Exposure menu appears.

Exposure menu:

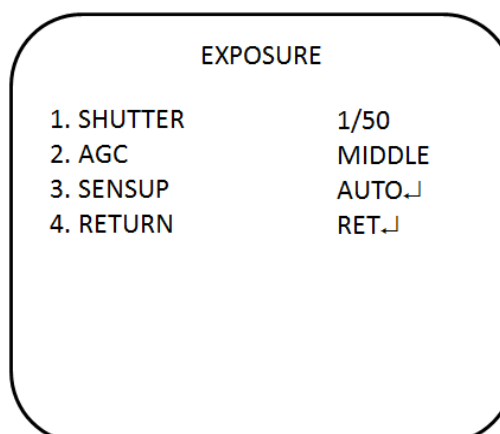

Menu Item	Description
Shutter	<p>1/50: Fixed value</p> <p>MANUAL: Define the manual shutter value. Select a higher value to see movement and a lower value to see clearer images. The values range from 1/50 to 1/100000.</p> <p>FLK: Flicker mode avoids interference from light sources.</p> <p>AUTO: The camera sets the optimum shutter speed. You can define the maximum shutter speed in AUTO mode. The values range from FLK to 1/100000.</p>

Menu Item	Description
AGC	Adjust the maximum automatic gain control level that is used in low-light conditions with the iris fully open. The values range from OFF to High.
SENSUP	The setting refers to the amount of light being allowed to load on the sensor from twice the "normal" light up to 256-times the "normal" light. This method can allow for brilliant, clear color images to be taken in nearly total darkness. The values range from x2 to x256.
Return	Exit the menu and return to live mode. Changes made are saved.

Backlight

In the Main menu, go to **Backlight** and select the options (**DWDR**, **HLC**, **BLC**, or **OFF**) to be modified in the menu. Note that this can be set up only if **DAY&NIGHT** is set to **COLOR** mode.

DWDR menu:

Digital wide dynamic range (**DWDR**) allows you to see details of objects in shadows or details of objects in bright areas that have high contrast between light and dark areas. An example is the headlights of a passing car.

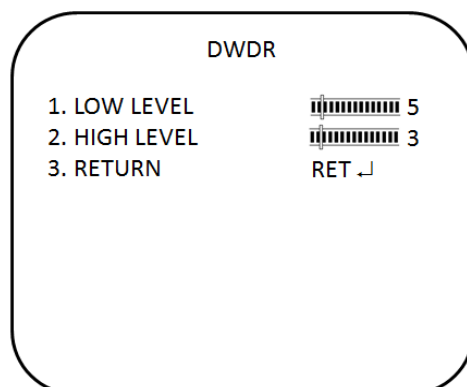

Low level: Set the low level of DWDR. The values range from 0 to 15

High level: Set the high level of DWDR. The values range from 0 to 15

BLC menu:

BLC (backlight compensation) can improve image quality when the background illumination is high. It prevents the object in the center from appearing too dark.

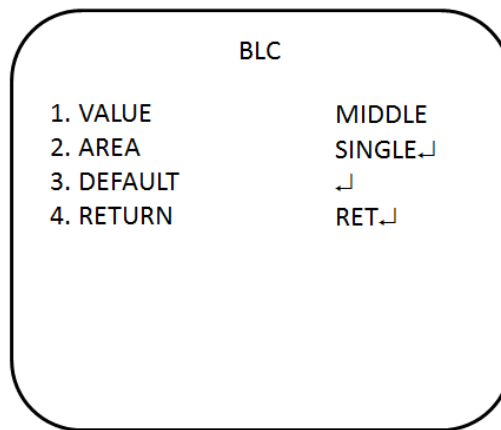

Value: Set the value level of backlight compensation. The values range from low to high.

Area: Set the area of the backlight compensation by position and the size. If need to define two backlight areas, please select DOUBLE.

Default: Reset to default the backlight compensation setting and area.

HSBLC menu:

HSBLC (high spotlight backlight compensation) masks strong light sources, giving darker areas more detail. It is often used to help identify vehicle license plate numbers, for example. You can adjust and select the specific area to observe the target object located under strong spots of light.

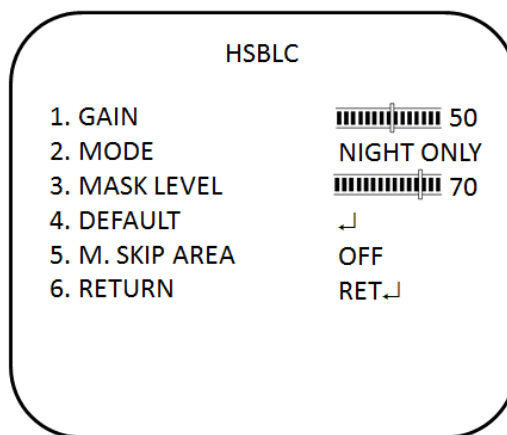

Menu Item	Description
Gain	Adjust gain value. The values range from 0 to 100.
Mode	Only available when HSBLC is enabled. It can be set to NIGHT ONLY or ALL DAY.
Mask level	Define the mask level. The values range from 0 to 100.
Default	Reset to default the backlight compensation setting and area.
Mask skip area	Set the value to ON or OFF to enable or disable the mask skip area.
Return	Exit the menu and return to live mode. Changes made are saved.

White balance

White balance (WB) tells the camera what the color white looks like. Based on this information, the camera will then continue to display all colors correctly even when the color temperature of the scene changes such as from daylight to fluorescent lighting, for example.

In the Main menu, go to **White Bal** and select the options to be modified:

Menu Item	Description
ATW	ATW (automatic tracing white balance) will be used depends on the lighting condition selected. It ensures reliable color reproduction when lighting conditions change frequently.
AWB	AWB (auto white balance). The camera adjusts the WB itself
AWC-SET	WB is automatically adjusted to the current environment and lock it at this value.
Manual:	Manually adjust the white balance by blue gain only. The red gain is automatically adjusted when the blue gain is changed. Only use this function when there is steady light.
Return	Exit the menu and return to live mode. Changes made are saved.

Day/Night mode

In the main menu, select **Day&Night** to open the day/night menu. The **Day&Night** mode has three options: Auto, BW and Color.

D&N Auto mode:

Select Auto so that the camera can automatically switch between day (color) and night (black and white) mode.

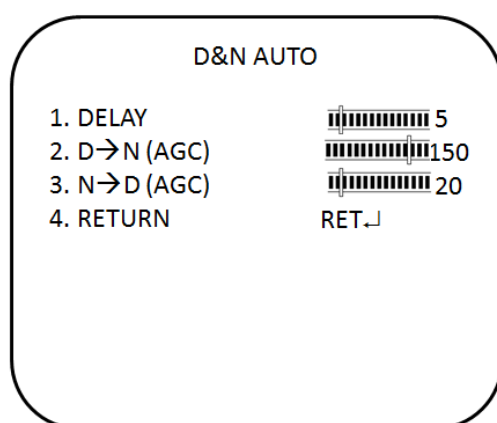

Menu Item	Description
Delay	This is the time in seconds before Day↔Night switches. A long delay response would be used, for example, to avoid switching from Night to Day mode when car headlights pass in front of the camera. The values range from 0 to 15.
Day→Night	Set the threshold level on how dark it should be before switching from Day to Night mode. Lower (Higher) value switches camera from Day to

Menu Item	Description
	Night at lower (higher) illumination. The values range from 16 to 176.
Night→Day	Set the threshold level on how light it should be before switching from Night to Day mode. The values range from 0 to 160.
Return	Exit the menu and return to live mode. Changes made are saved.

D&N BW mode:

Select BW to manually set the camera to black and white mode

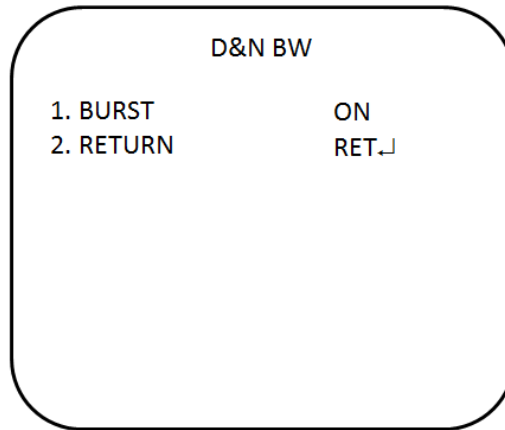

Burst: Enable/disable the color burst component of the video signal when the camera switches to B/W.

- **ON** mode maintains the same color signal in B/W so that the video signal provides better compatibility with certain color equipment.
- **OFF** mode removes the color burst signal B/W video and increase the total TV lines.

COLOR mode:

Select Color to manually set the camera to color (day) mode.

Image noise reduction

Smart 3DNR noise reduction reduces the background noise in a low luminance environment with 2D + 3D filtering system.

In the Main menu, select **SMART 3DNR** to set up noise reduction.

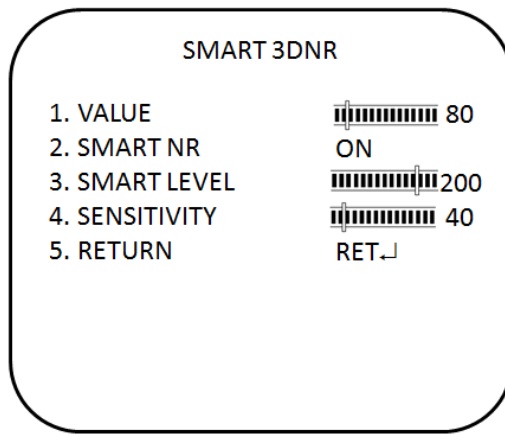

Menu Item	Description
Value	Set the desired 3DNR value. The values range from 1 to 200. The higher the value, the larger the pixel size. The lower the value, the smaller the pixel size.
Smart NR	This is three-dimensional noise reduction. Enable or disable the smart NR function.
Smart level	Set the smart NR level. The values range from 1 to 200. The smaller the value, noise is more visible but the picture is sharper. The larger the value, noise is less visible but the picture is less sharp.
Sensitivity	Set the Smart NR sensitivity for activation. The values range from 1 to 200. The larger the value, the greater the sensitivity.
Return	Exit the menu and return to live mode. Changes made are saved.

Defog

This feature helps to improve visibility of the camera image during poor weather conditions, such as fog and smog.

In the main menu, select DE-FOG to enable the feature. There are three options: off, auto and manual.

De-fog auto mode

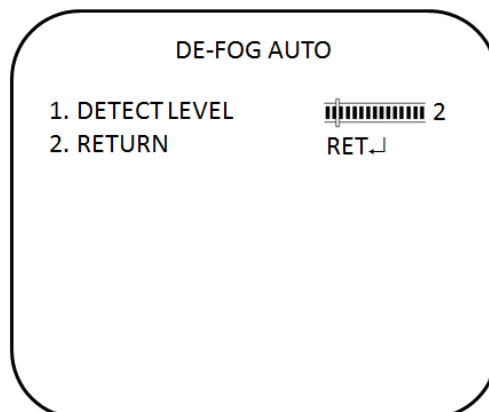

Detect level: set the detect level for activation. The values range from to 1 to 5.

De-fog manual mode

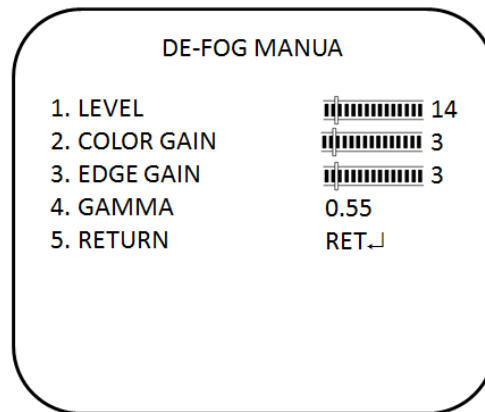

Menu Item	Description
Level	Set the de-fog level. The values range from 0 to 31.
Color gain	Set the color gain level. The values range from 0 to 10.
Edge gain	Set the edge gain level. The values range from 0 to 10.
Gamma	Set the gamma level. The values range from 0.05 to 1.00.
Return	Exit the menu and return to live mode. Changes made are saved.

Function menus

There are additional functions available under this menu.

In the Main menu, select **Function** and press Enter. The Function menu appears, showing the options available.

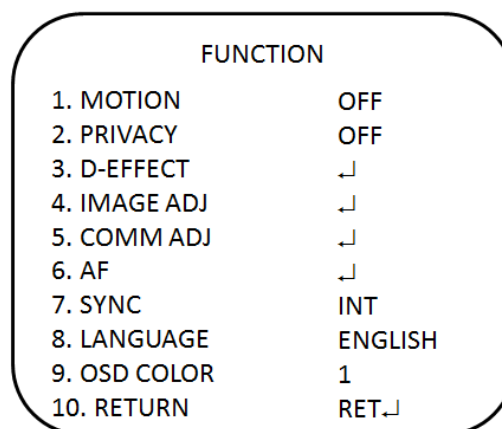

Menu item	Description
Motion	Set the motion detection
Privacy	Set the privacy mask
D-effect	Set digital effect
Image adj	Set the image adjustment
Comm adj	Set the communication protocol settings

AF	Set the auto focus settings
Sync	Set the synchronization
Language	Set the OSD language
Osd color	Set the OSD color
Return	Exits the menu and returns to live mode

Motion detection

In the Function menu, go to **Motion** and press **Enter**. The Motion menu appears, showing the options available.

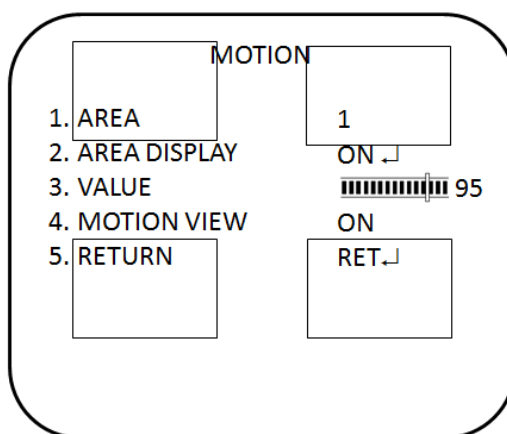

Menu Item	Description
Area	Select the motion detection zone (AREA1, AREA2, AREA3) that you want to configure. The selected zone blinks.
Area display	Enable or disable motion detection for the selected zone. If enabled, you can also customize the position and size of the zone.
Value	Set the sensitivity level for the motion trigger. When the sensitivity level is high, motion detection can be triggered by the slightest of movement. The values range from 0 to 100.
Motion view	Choose whether to show motion blocks when the camera detects motion in the selected zone.
Return	Exit the menu and return to live mode. Changes made are saved.

Privacy mask area

Use this function to mask areas that you want to hide on screen to protect privacy, such as a neighboring building. You can mask up to eight areas using a variety of colors.

In the **Function** menu, go to **Privacy** and press **Enter**. The Privacy menu appears, showing the options available.

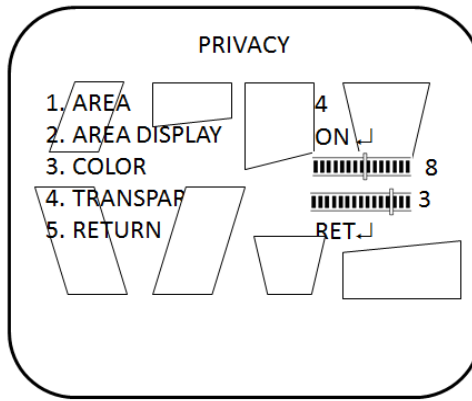

Menu Item	Description
Area	Select the privacy mask (AREA1 to AREA8) that you want to configure. Each privacy mask is already associated with a pre-selected color that you can change using the COLOR setting.
Area display	Enable or disable the selected privacy mask. If enabled, you can also customize the position and size of the privacy mask.
Color	Set the color of the privacy mask. There are 16 colors available.
Transpar	Set the level of transparency of the privacy mask. The values range from 0 to 3. Level 0 lets you see behind the mask. Level 3 means the mask will entirely cover the area.
Return	Exit the menu and return to live mode. Changes made are saved.

Digital effect

In the **Function** menu, go to **D-effect** and press **Enter**, the below figure shows the different options available

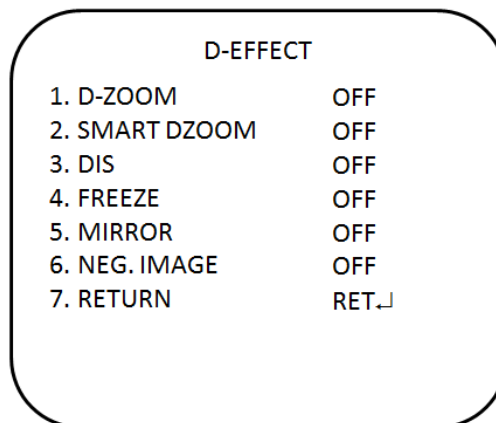

D-Zoom

When the digital zoom is enabled, you can zoom in the camera on a specific area during live view.

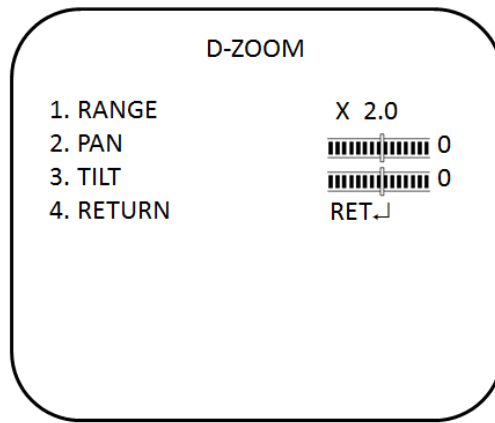

- **Range:** Digital zoom in / out. The values range from x1 to x32.
- **Pan:** Set the pan location when D-zoom is enabled. The values range from -100 to +100.
- **Tilt:** Set the tilt location when D-zoom is enabled. The values range from -100 to +100.

Smart-zoom

When a motion is detected in a pre-defined area, the camera picture will zoom in on the area and then zoom out.

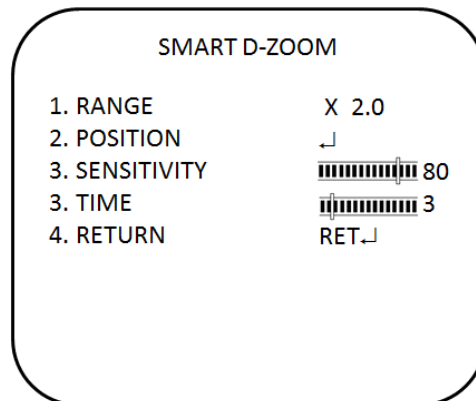

- **Range:** Set the zoom in time. The values range from x1 to x5.
- **Position:** Set the zoom area. When a motion is detected, it automatically zooms in/out.
- **Sensitivity:** Set the sensitivity level for activation.
- **Time:** Define the desired time value for the display of zoom in/out.

DIS

The **DIS** function (digital image stabilizer) helps to neutralize light camera vibrations. It can be On or Off.

Freeze

The **FREEZE** function helps to hold the image to analyze precisely.

Mirror

The MIRROR function helps change the orientation of the image: horizontally reversed (MIRROR), upside down (V-FLIP) or horizontally reversed upside down (ROTATE). Using this mode does not affect the orientation of text on the screen.

Neg. Image

The NEG IMAGE Display the image in a negative exposed format.

Image adjustment

In the Function menu, go to **Image Adj** and press **Enter**. The Image Adjustment menu appears, showing the options available.

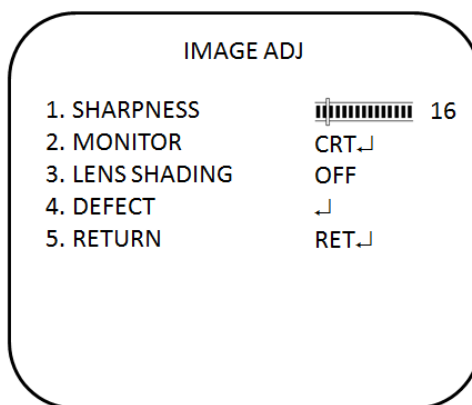

Sharpness: Set the image sharpness level between 0 and 31. Setting the sharpness too high will make your pictures look pixelated, like old computer graphics. However, setting the sharpness level too low will make everything look soft and blurry.

Monitor: Select the monitor type that is closest to the type you are using. In the Monitor submenu, there are CRT and LCD options. You can also manually adjust the gamma, blue gain, and red gain levels for the selected monitor type.

Lens Shading: Enable this option to brighten the edges of the camera image.

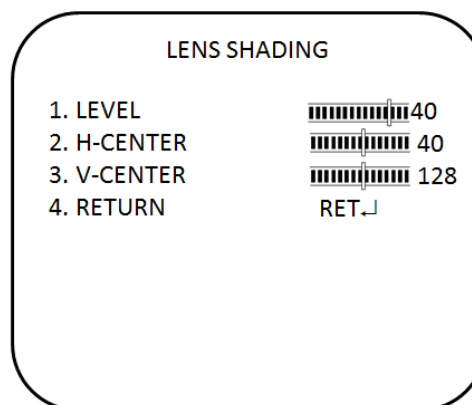

- **Level:** Set the level of the lens shading correction. The values range from 0 to 60

- **H-center:** Set the horizontal center location. The values range from 0 to 255.
- **V-center:** Set the vertical center location. The values range from 0 to 255.

Defect: If the camera's image sensor displays some defective pixels, this could be due to them responding to light exposure differently compared to the surrounding pixels. Use the Defective Pixel Correction (DPC) function to enable the camera to digitally correct defective pixels using its image signal processor.

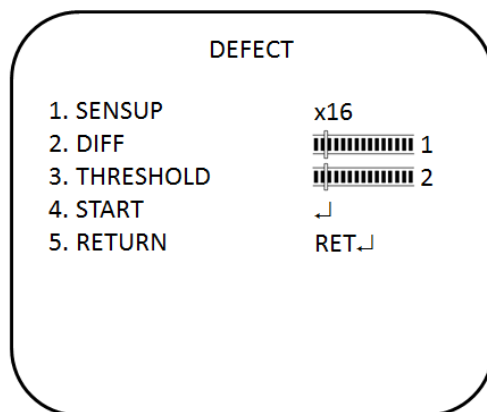

- **Sensup:** Adjust the magnification of existing light sources to make it easier for the camera to detect defective pixels. If set too strong, the camera can regular noise mistakenly as defective pixels. The values range from x4 to x128.
- **Diff:** Set a value to increase the difference between surrounding pixels to find a dead pixel. The larger the value, the larger the size of the dead pixel found. The values range from 0 to 3.
- **Threshold:** Set threshold value. The values range from 0 to 4.
- **Start:** Perform STATIC DPC. The camera closes the lens automatically and detects defective pixels that exceed the specified level. You need to cover the lens with your hand during the test.

Protocol adjustment

In the Function menu, go to **Comm ADJ** and press **Enter**. The Comm ADJ menu appears, showing the options available.

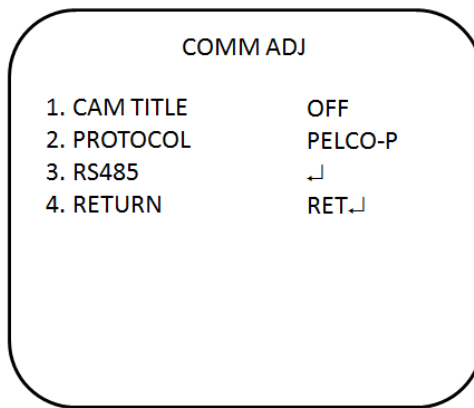

Set Camera title: The camera ID displayed on-screen can have up to 53 characters

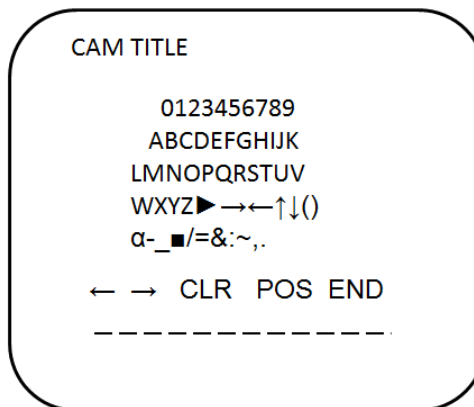

To enter a character:	Move the cursor to the desired character and press Enter to select it. It appears in the input line. Repeat the process until all characters are entered.
To move a character:	Enter the position in the input line, move the cursor in the command line to ← or → and press Enter.
To clear the input line:	Move the cursor to CLR and press Enter.
To delete a character in the input line:	Select the character so that it blinks. Then move the cursor to CLR on the command line and press Enter.
To position the camera ID on-screen:	Move the cursor to POS and press Enter. The menu disappears on-screen and the camera ID is displayed on the monitor. Use the menu button to move the camera ID to the desired position. Press Enter. The menu reappears. Select Return to return to the previous menu.

RS485: This function allows you to configure the camera's RS485 protocol settings.

RS485	
1. CAM ID	1
2. ID DISPLAY	ON↵
3. BAUDRATE	9600
4. RETURN	RET↵

- **Camera ID:** Set the camera ID. The values range from 1 to 255.
- **ID display:** Enable or disable the ID display on screen. Press LEFT or RIGHT enable or disable.
- **Baud rate:** Set the baud rate between the camera and controller. The values range from 2400 to 57600.

Autofocus

In the **Function** menu, go to **AF** and press **Enter**. The AF menu appears, showing the options available.

AF	
1. AF FUNC	ON
2. SEMI-AF	INITIAL↵
3. D/N AF	ON
4. DELAY	5
5. RETURN	RET↵

- **AF func:** Enable or disable the auto focus function. Press LEFT or RIGHT to choose a value.
- **Semi-AF:** Reset the autofocus to the factory default setting.
- **D/N AF:** Enable or disable the day and night autofocus. When the camera switches from day to night or from night to day, it adjusts the autofocus to ensure an accurate picture.
- **Delay:** Defines the delay time for autofocus. The values range from 5 to 10.

Display the synchronization mode

Use the **Sync** menu to display the current synchronization mode. Only one option is available: Internal.

OSD language

In the **Function** menu, go to **Language** and press **Enter**.

Use this menu to select the OSD language. Select the desired language. There are 16 languages are available. Press Right or Left to choose the language. The languages are:

English, Korean, Japanese, Chinese Traditional, Chinese Simplified, Russian, French, Spanish, Italian, Portuguese, Dutch, German, Polish, Turkish, Hebrew, Arabic.

Exit menu

You can return to the upper level of the OSD or save current setting and exit the OSD.

Press Right or Left to choose the value and press Enter to validate.

Specifications

TVB-2104/TVB4104

Lens type	Varifocal: 2.8 to 11 mm
Power supply	24 VAC / 12 VDC
Current	12VDC Max 840 mA 24VAC / Max 610 mA
Power consumption	12 VDC Max10 W 24 VAC Max: 9.5 W
Operating temperature	-10 to 50°C (14 to 122°F)
Weight	2.08 lb. (945 g)

TVB-2105/TVB4105

Lens type	Varifocal: 5 to 50 mm
Power supply	24 VAC / 12 VDC
Current	12VDC Max 1.2A 24VAC / Max 800 mA
Power consumption	12 VDC Max14.2 W 24 VAC Max: 13 W
Operating temperature	-10 to 50°C (14 to 122°F)
Weight	2.08 lb. (945 g)

Menu Tree

