

GE
Security

GE-DSG-8 DSGH-5 and 8 Ethernet Switch User Manual



Copyright © 2010 GE Security, Inc.

This document may not be copied in whole or in part or otherwise reproduced without prior written consent from GE Security, Inc., except where specifically permitted under US and international copyright law.

Disclaimer The information in this document is subject to change without notice. GE Security, Inc. ("GE Security") assumes no responsibility for inaccuracies or omissions and specifically disclaims any liabilities, losses, or risks, personal or otherwise, incurred as a consequence, directly or indirectly, of the use or application of any of the contents of this document. For the latest documentation, contact your local supplier or visit us online at www.gesecurity.com.

This publication may contain examples of screen captures and reports used in daily operations. Examples may include fictitious names of individuals and companies. Any similarity to names and addresses of actual businesses or persons is entirely coincidental.

Trademarks and patents GE and the GE monogram are trademarks of General Electric Company.

Other trade names used in this document may be trademarks or registered trademarks of the manufacturers or vendors of the respective products.

Intended use Use this product only for the purpose it was designed for; refer to the data sheet and user documentation for details. For the latest product information, contact your local supplier or visit us online at www.gesecurity.com.

This product is intended to be supplied by a UL Listed Direct Plug-In Power Unit marked "Class 2" or "LPS" and output rated 48 VDC, 380 mA minimum.

FCC compliance This equipment has been tested and found to comply with the limits for a Class A digital device, pursuant to part 15 of the FCC Rules. These limits are designed to provide reasonable protection against harmful interference when the equipment is operated in a commercial environment. This equipment generates, uses, and can radiate radio frequency energy and, if not installed and used in accordance with the instruction manual, may cause harmful interference to radio communications.

You are cautioned that any changes or modifications not expressly approved by the party responsible for compliance could void the user's authority to operate the equipment.

Regulatory information



Manufacturer

GE Security, Inc.

HQ and regulatory responsibility:

GE Security, Inc., 8985 Town Center Parkway, Bradenton, FL 34202, USA

EU authorized manufacturing representative:

GE Security B.V., Kelvinstraat 7, 6003 DH Weert, The Netherlands

European Union directives



2002/96/EC (WEEE directive): Products marked with this symbol cannot be disposed of as unsorted municipal waste in the European Union. For proper recycling, return this product to your local supplier upon the purchase of equivalent new equipment, or dispose of it at designated collection points. For more information see: www.recyclethis.info.

Contact information

For contact information see our Web site: www.gesecurity.com.

For contact information see our Web site: www.gesecurity.eu.

Content

Chapter 1 Introduction 1

- Package Contents 1
- How to use this Manual 2
- Product Features 2

Chapter 2 Installation 5

- Product Description 5
- Wiring the Fault Alarm Contact 9

Chapter 3 Application 13

- Installation Steps 14

Chapter 4 Switch Operation 15

- Address Table 15
- Learning 15
- Forwarding & Filtering 15
- Store-and-Forward 16
- Auto-negotiation 16

Chapter 5 Troubleshooting 17

Appendix A Network Connection 19

- Switch's RJ-45 Pin Assignments 19
- RJ-45 Connector pin assignment 20

Chapter 1

Introduction



GE-DSGH-5



GE-DSGH-8



GE-DSG-8

The GE Security GE-DSG/DSGH series is a 5 and 8-Port 10/100/1000Mbps Industrial Gigabit Ethernet Switch with non-blocking wire-speed performance and new slim type IP 30 metal shape for easy deployment in Heavy Industrial demanding environments.

Package Contents

Check the contents of your package for following parts:

- Industrial Gigabit Ethernet Switch x 1
- User's Manual x 1
- DIN Rail Kit x 1
- Wall Mount Kit x 1

If any of these are missing or damaged, please contact your dealer immediately, if possible, retain the carton including the original packing material, and use them against to repack the product in case there is a need to return it to us for repair.

How to use this Manual

This User Manual is structured as follows:

| Section | Section Content |
|-------------------------|---|
| INTRODUCTION | Product description with features and specifications |
| INSTALLATION | Explains the features/functions of the Industrial Gigabit Ethernet Switch, and how to physically install the Industrial Gigabit Ethernet Switch |
| APPLICATION | Explains the Industrial Gigabit Ethernet Switch application |
| SWITCH OPERATION | Explains the Industrial Gigabit Ethernet Switch transmit operation |
| TROUBLESHOOTING | Describes how to troubleshoot the Industrial Gigabit Ethernet Switch |
| APPENDIX A | Contains cable information for the Industrial Gigabit Ethernet Switch |

Product Features

Physical Port

- 5-Port 10/100/1000Base-T RJ-45 with auto MDI/MDI-X function (GE-DSGH-5)
- 8-Port 10/100/1000Base-T RJ-45 with auto MDI/MDI-X function (GE-DSG-8 / GE-DSGH-8)

Layer 2 Features

- Complies with IEEE 802.3 10Base-T, IEEE 802.3u 100Base-TX, IEEE 802.3ab 1000Base-T Ethernet standard
- Supports Auto-negotiation and 10/100Mbps half / full duplex and 1000Mbps full duplex mode
- High performance Store and Forward architecture, broadcast storm control, runt/CRC filtering eliminates erroneous packets to optimize the network bandwidth
- Prevents packet loss with back pressure (Half-Duplex) and IEEE 802.3x PAUSE frame flow control (Full-Duplex)
- Integrated address look-up engine, support 8K absolute MAC addresses
- 9K Jumbo packet size support
- Automatic address learning and address aging

- CSMA/CD Protocol

Industrial Case / Installation

- IP-30 Metal case / Protection
- DIN Rail and Wall Mount Design
- 12 to 48V DC, redundant power with polarity reverse protect function and connective removable terminal block for master and slave power
- -10 to 60 Degree C operating temperature on MC-4TX1FXMM-2km / MC-4TX1FXSM-15KM / MC-4TX2FX

Product Specifications

| Model | GE-DSGH-5 | GE-DSGH-8 | GE-DSG-8 |
|---------------------------------------|---|--------------------|--------------------|
| Hardware Specification | | | |
| 10/100/1000Base-T Ports | 5 | 8 | 8 |
| Installation | DIN rail kit and wall mount ear | | |
| Dimension (W x D x H) | 5.31 x 3.42 x 1.26 inch / 135 x 87 x 32mm | | |
| Weight (lbs) | 1.0 lbs | 1.045 lbs | 1.045 lbs |
| EFT | 6KV | | |
| ESD | 6KV | | |
| Electronic Specification | | | |
| Power Input | 12~48 VDC, Redundant power | | |
| Power Consumption | 11.9 Watts / 40BTU | 13.2 Watts / 45BTU | 13.2 Watts / 45BTU |
| Power Connector | 6-pin removable screw terminal | | |
| Switch Specification | | | |
| Switch Processing Scheme | Store-and-Forward | | |
| Address Table | 8K entries | | |
| Buffer | 176 kilobytes | | |
| Flow Control | Back pressure for half duplex, IEEE 802.3x Pause Frame for full duplex | | |
| Switch fabric | 10Gbps | 16Gbps | 16Gbps |
| Throughput (Packet per second) | 7.44Mpps@64bytes | 11.9Mpps@64bytes | 11.9Mpps@64bytes |
| Jumbo Frame | 9Kbytes | | |
| Network cables | 10/100/1000Base-T: Cat. 3, 4, 5, 5e, 6 UTP cable (100meters, max.) EIA/TIA-568 100-ohm STP (100meters, max.) | | |
| Environment Specification | | | |
| Operating Temperature | -40°C ~75°C | -40°C ~75°C | -10°C ~60°C |
| Operating Humidity | 5% ~ 95% (non-condensing) | | |
| Storage Temperature | -40°C ~85°C | -40°C ~85°C | -40°C ~85°C |
| Storage Humidity | 5% ~ 95% (non-condensing) | | |
| Standards Conformance | | | |
| Standards Compliance | IEEE 802.3 Ethernet IEEE 802.3u Fast Ethernet IEEE 802.3ab Gigabit Ethernet IEEE 802.3x Full-duplex flow control | | |
| Stability testing | IEC60068-2-32 (Free fall), IEC60068-2-27 (Shock), IEC60068-2-6 (Vibration) | | |

Chapter 2

Installation

This section describes the features of the Industrial Gigabit Ethernet Switch's components and guides you how to install it on the desktop. Basic knowledge of networking is assumed. Please read this chapter completely before continuing.

Product Description

The GE Security GE-DSGH-5 and the GE-DSGH-8 are 5/8-Port 10/100/1000Mbps Industrial Gigabit Ethernet Switches with non-blocking wire-speed performance with a new slim type with IP 30 metal shape for easy deployment in Heavy Industrial demanding environments.

With a 10/16Gbps internal switching fabric, the Industrial Gigabit Ethernet Switch can handle extremely large amounts of data in a secure topology linking to a backbone or high capacity servers.

The Industrial Gigabit Ethernet Switch has 8K MAC Address table and offers wire-speed packets transfer performance without risk of packet loss. The Gigabit ports with 9K jumbo packet support can handle large amounts of data transmission in a secure topology linking to a backbone or high-power servers. The high data throughput of the device makes it ideal for most Gigabit environments.

All RJ-45 copper interfaces support 10/100/1000Mbps Auto-Negotiation for optimal speed detection through RJ-45 Category 6, 5 or 5e cables. Support standard for Auto-MDI/MDI-X that can detect the type of connection to any Ethernet device without requiring special straight or crossover cables.

The Flow Control function allows Industrial Gigabit Ethernet Switch supported routers and Servers to directly connect to this device for fast, reliable data transfer.

Product Overview

The GE Security Industrial Gigabit Ethernet Switch with 5/8 RJ-45 10/100/1000Mbps ports for high-speed network connectivity. The Industrial Gigabit Ethernet Switch can also automatically identify and determine the correct transmission speed and half / full duplex mode of the attached devices with its 5/8 ports. The Gigabit port with 9K jumbo frame feature supported, can handle extremely large amounts of data transmission in a secure topology linking to a backbone or high-power servers.

The Industrial Gigabit Ethernet Switch also supports Store-and-Forward forwarding scheme to ensure low latency and high data integrity, eliminates unnecessary traffic and relieves congestion on critical network paths. With an intelligent address recognition algorithm, the Industrial Gigabit Ethernet Switch can recognize up to 8K different MAC address and enables filtering and forwarding at full wire speed.

Switch Front Panel

Figure 1 shows the front panels of Industrial Gigabit Ethernet Switch.

Figure 1: GE DSG-8 GE-DSGH-5 and GE-DSGH-8 front panels

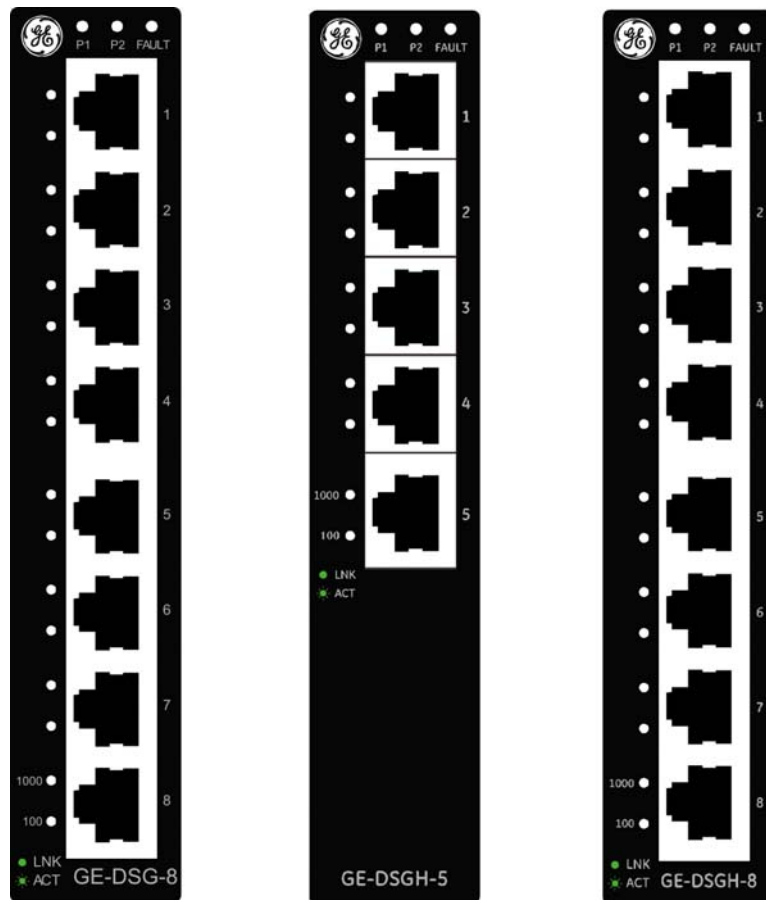

Led Indicators

LED Indicators

| LED | Color | Function |
|-------|-------|---|
| P1 | Green | Lit: indicates the power 1 has power. |
| P2 | Green | Lit: indicates the power 2 has power. |
| FAULT | Green | Lit: indicates the either power 1 or power 2 has no power. |
| 1000 | Green | Lit: indicates the Switch is successfully connecting to the network at 1000Mbps. Off: indicates that the Switch is successfully connecting to the network at 10 or 100Mbps. Blink: indicates that the Switch is actively sending or receiving data over that port |
| 100 | Green | Lit: indicates the Switch is successfully connecting to the network at 100Mbps. Off: indicates that the Switch is successfully connecting to the network at 10 or 100Mbps. |

Switch Upper Panel

The upper panel of the Industrial Gigabit Ethernet Switch consists of one terminal block connector within two DC power inputs. Figure 2 shows the upper panel of the Industrial Gigabit Ethernet Switch.

Figure 2: Industrial Gigabit Ethernet Switch Upper Panel

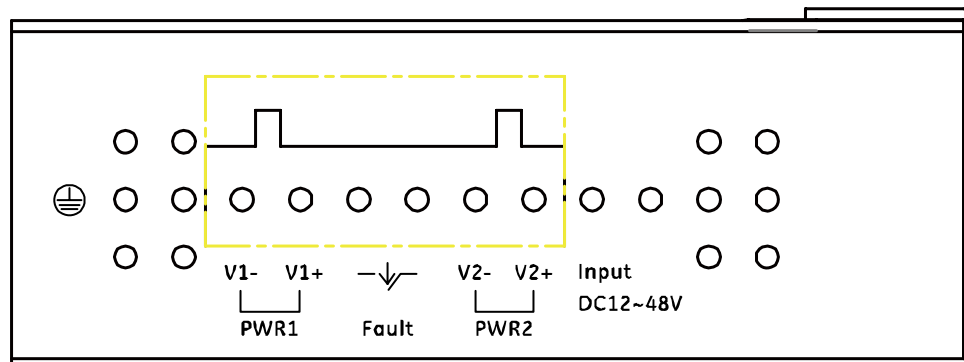

Wiring the Power Inputs

The 6-contact terminal block connector on the top panel of Industrial Gigabit Ethernet Switch is used for two DC redundant powers input. Please follow the steps below to insert the power wire.

1. Insert positive / negative DC power wires into the contacts 1 and 2 for POWER 1, or 5 and 6 for POWER 2.

NOTE: This product is intended to be supplied by a UL Listed Direct Plug-In Power Unit marked "Class 2" or "LPS" and output rated 48 VDC, 380 mA minimum.

Figure 3: Power Inputs

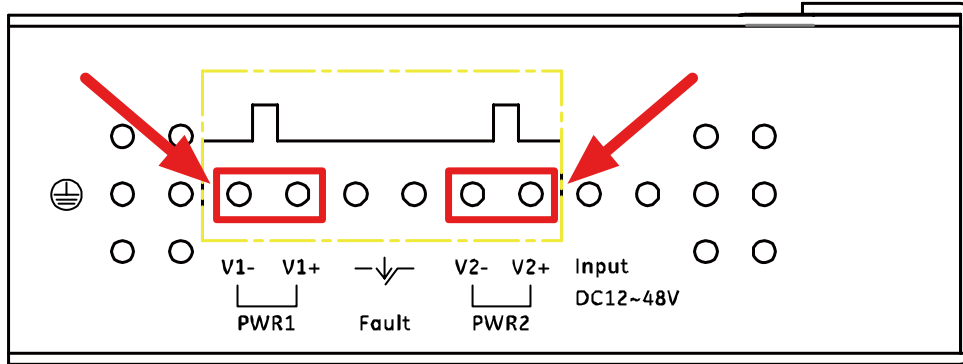

V1- V1 + V2 - V2 +

2. Tighten the wire-clamp screws for preventing the wires from loosing.

Figure 3: Terminal Block

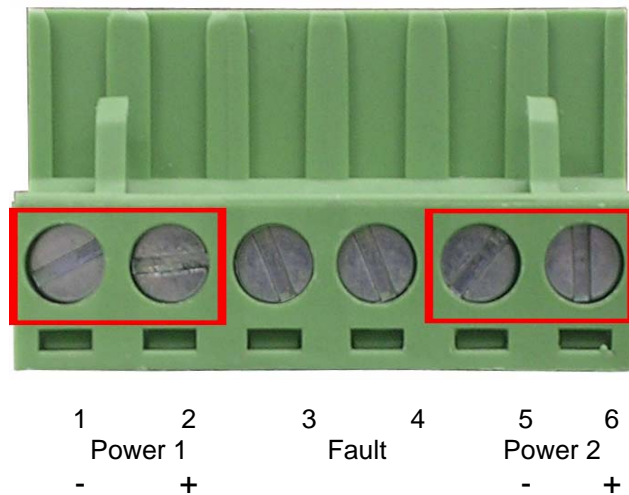

Note: The wire gauge for the terminal block should be in the range between 12 ~ 24 AWG.

Wiring the Fault Alarm Contact

The fault alarm contacts are in the middle of the terminal block connector as the picture shows below. Inserting the wires, the Industrial Gigabit Ethernet Switch will detect the fault status of a power failure, or port link failure (available for managed model) and then forms an open circuit. The following illustration shows an application example for wiring the fault alarm contacts.

Figure 4: Fault Alarm contacts

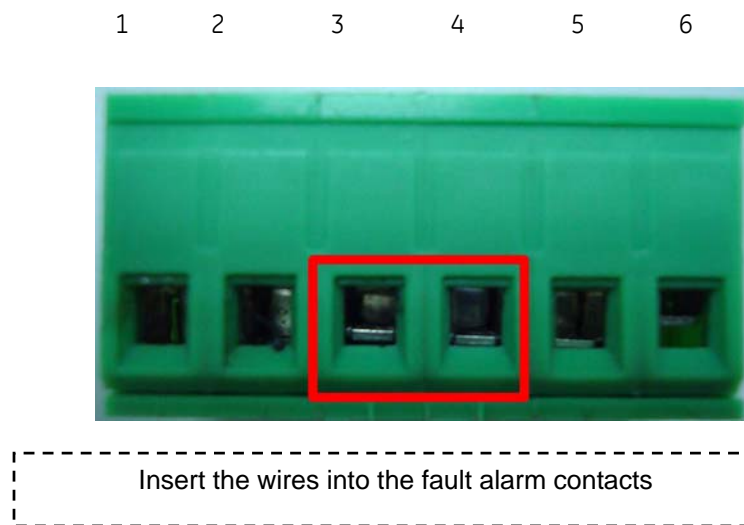

Note: The wire gauge for the terminal block should be in the range between 12 ~ 24 AWG. Alarm relay circuit accepts up to 30V, max. 3A currents.

Figure 5: Alarm schematic

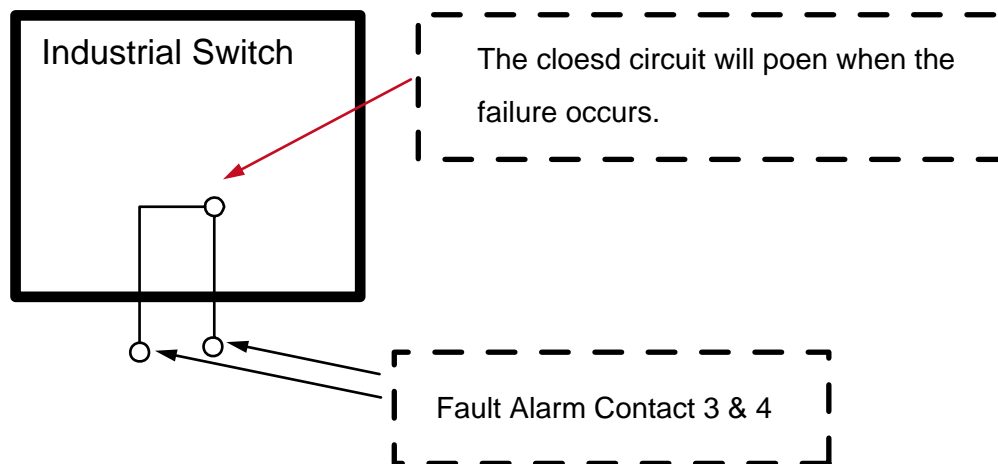

Mounting Installation

This section describes how to install the Industrial Gigabit Ethernet Switch and make connections to it. Please read the following topics and perform the procedures in the order being presented.

Note: In the installation steps below, this Manual use IGS-801 (GE Security 8 Port Industrial Gigabit Switch) as an example. However, the steps for GE Security Industrial Switch & Industrial Media Converter are similar.

Industrial DIN-Rail Mounting

The DIN-Rail is screwed on the Industrial Gigabit Ethernet Switch when in the factory. If you need to replace the wall mount application with DIN-Rail application on Industrial Gigabit Ethernet Switch, please refer to following figures to screw the DIN-Rail on the Industrial Gigabit Ethernet Switch. To hang the Industrial Gigabit Ethernet Switch, follow the below steps:

1. Screw the DIN-Rail on the Industrial Gigabit Ethernet Switch.



2. Lightly press the button of DIN-Rail into the track.



3. Check that the DIN-Rail is tightly secured on the track.



4. Please refer to following procedures to remove the Industrial Gigabit Ethernet Switch from the track.
5. Lightly press the button of DIN-Rail for remove it from the track.



Wall Plate Mounting

To install the Industrial Gigabit Ethernet Switch on the wall, please follow the instructions described below.

1. Remove the DIN-Rail from the Industrial Gigabit Ethernet Switch; loosen the screws to remove the DIN-Rail.
2. Place the wall mount plate on the rear panel of the Industrial Gigabit Ethernet Switch.



3. Use the screws to secure the wall mount plate on the Industrial Gigabit Ethernet Switch.
4. Use the hook holes at the corners of the wall mount plate to hang the Industrial Gigabit Ethernet Switch on the wall.
5. To remove the wall mount plate, reverse the steps above.

Chapter 3

Application

In this section, we will describe how to install the Industrial Gigabit Ethernet Switch into a typical application environment

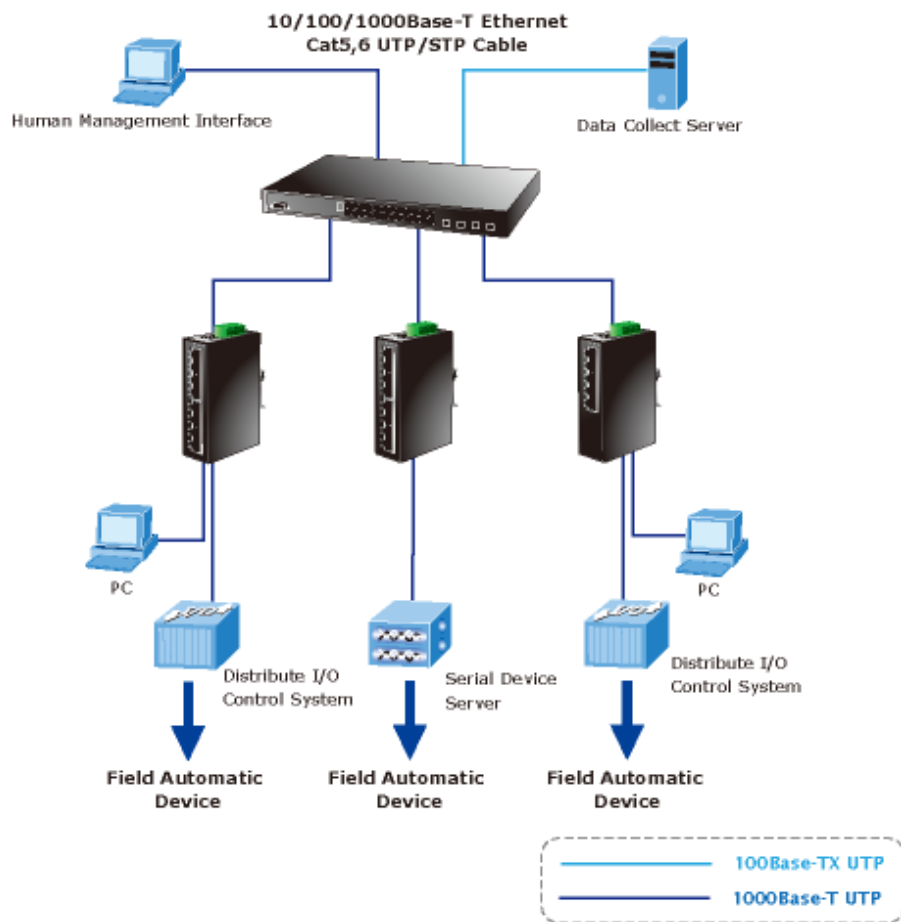

Installation Steps

1. Unpack the Industrial Gigabit Ethernet Switch.
2. Check the DIN-Rail is screwed on the Industrial Gigabit Ethernet Switch. (Please refer to DIN-Rail Mounting section for DIN-Rail installation. If the DIN-Rail is not screwed on the Industrial Gigabit Ethernet Switch.). If you want to wall mount the Industrial Gigabit Ethernet Switch, then please refer to Wall Mount Plate Mounting section for wall mount plate installation.
3. To hang the Industrial Gigabit Ethernet Switch on the DIN-Rail track or wall, please refer to the Mounting Installation section.
4. Power on the Industrial Gigabit Ethernet Switch. (Please refer to the Wiring the Power Inputs section for power input) The power LED on the Industrial Gigabit Ethernet Switch will light up. Please refer to the LED Indicators section for meaning of LED lights.
5. Prepare the twisted-pair, straight through Category 5 cable for Ethernet connection.
6. Insert one side of Category 5 cables into the Industrial Gigabit Ethernet Switch Ethernet port (RJ-45 port) and another side of category 5 cables to the network devices' Ethernet port (RJ-45 port), ex: Switch, PC or Server. The UTP port (RJ-45) LED on the Industrial Gigabit Ethernet Switch will light up when the cable connected with the network device. Please refer to the LED Indicators section for LED light meaning.

Note: Be sure the connected network devices support MDI/MDI-X. If it does not support then use the crossover category 5 Cable.

7. When all connections are all set and LED lights all show normal, the installation is complete.

Chapter 4

Switch Operation

Address Table

The Industrial Gigabit Ethernet Switch is implemented with an address table. This address table is composed of many entries. Each entry is used to store the address information of some node in network, including MAC address, port no., etc. This information is automatically obtained by the Industrial Gigabit Ethernet Switch.

Learning

When one packet comes in from any port. The Industrial Gigabit Ethernet Switch will record the source address, and port number, and the other related information in address table. This information will be used to decide either forwarding or filtering for future packets.

Forwarding & Filtering

When one packet comes from some port of the Industrial Gigabit Ethernet Switch, it will also check the destination address besides the source address learning. The Industrial Gigabit Ethernet Switch will lookup the address-table for the destination address. If not found, this packet will be forwarded to all the other ports except the port which this packet comes in. And these ports will transmit this packet to the network it connected. If found, and the destination address is located at different port from this packet comes in, the Industrial Gigabit Ethernet Switch will forward this packet to the port where this destination address is located according to the

information from the address table. But, if the destination address is located at the same port with this packet comes in, then this packet will be filtered. Thereby increasing the network throughput and availability.

Store-and-Forward

Store-and-Forward is one type of packet-forwarding techniques. A Store-and-Forward Industrial Switch stores the incoming frame in an internal buffer, do the complete error checking before transmission. Therefore, no error packets occurrence, it is the best choice when a network needs efficiency and stability.

The Industrial Gigabit Ethernet Switch scans the destination address from the packet-header, searches the routing table provided for the incoming port and forwards the packet, only if required. The fast forwarding makes the switch attractive for connecting servers directly to the network, thereby increasing throughput and availability. However, the switch is most commonly used to segment existing hubs, which nearly always improves overall performance. An Ethernet Switching can be easily configured in any Ethernet network environment to significantly boost bandwidth using conventional cabling and adapters.

Due to the learning function of the Industrial Gigabit Ethernet Switch, the source address and corresponding port number of each incoming and outgoing packet are stored in a routing table. This information is subsequently used to filter packets whose destination address is on the same segment as the source address. This confines network traffic to its respective domain, reducing the overall load on the network.

The Industrial Gigabit Ethernet Switch performs "Store-and-Forward" therefore, no error packets occur. More reliably, it reduces the re-transmission rate. No packet loss will occur.

Auto-negotiation

The STP ports on the Industrial Gigabit Ethernet Switch have built-in "Auto-negotiation". This technology automatically sets the best possible bandwidth when a connection is established with another network device (usually at Power On or Reset). This is done by detect the modes and speeds at the second of both device is connected and capable of, both 10Base-T and 100Base-TX devices can connect with the port in either Half- or Full-Duplex mode.

Chapter 5

Troubleshooting

This chapter contains information to help you solve common issues. If the Industrial Gigabit Ethernet Switch is not functioning properly, make sure the Industrial Gigabit Ethernet Switch was set up according to instructions in this manual.

The per port LED is not lit

Solution:

Check the cable connection of the Industrial Gigabit Ethernet Switch.

Performance is bad

Solution:

Check the speed duplex mode of the partner device. The Industrial Gigabit Ethernet Switch is run at Auto-negotiation mode and if the partner is set to half duplex, then the performance will be poor.

Per port LED is lit, but the traffic is irregular

Solution:

Check that the attached device is not set to dedicate full duplex. Some devices use a physical or software switch to change duplex modes. Auto-negotiation may not recognize this type of full-duplex setting.

Why the Industrial Gigabit Ethernet Switch doesn't connect to the network

Solution:

Check per port LED on the Industrial Gigabit Ethernet Switch. Try another port on the Industrial Gigabit Ethernet Switch. Make sure the cable is installed properly. Make sure the cable is the right type. Turn off the power. After a minute, turn on the power again.

Why the Industrial Gigabit Ethernet Switch doesn't connect to the network

Solution:

Check per port LED on the Industrial Gigabit Ethernet Switch. Try another port on the Industrial Gigabit Ethernet Switch. Make sure the cable is installed properly. Make sure the cable is the right type. Turn off the power. After a while, turn on power again.

Appendix A

Network Connection

Switch's RJ-45 Pin Assignments

1000Mbps, 1000Base-T

| Contact | MDI | MDI-X |
|---------|--------|--------|
| 1 | BI_DA+ | BI_DB+ |
| 2 | BI_DA- | BI_DB- |
| 3 | BI_DB+ | BI_DA+ |
| 4 | BI_DC+ | BI_DD+ |
| 5 | BI_DC- | BI_DD- |
| 6 | BI_DB- | BI_DA- |
| 7 | BI_DD+ | BI_DC+ |
| 8 | BI_DD- | BI_DC- |

10/100Mbps, 10/100Base-TX

| RJ-45 Connector pin assignment | | |
|--------------------------------|-------------------------------------|--|
| Contact | MDI Media Dependant Interface | MDI-X Media Dependant Interface -Cross |
| 1 | Tx + (transmit) | Rx + (receive) |
| 2 | Tx - (transmit) | Rx - (receive) |
| 3 | Rx + (receive) | Tx + (transmit) |
| 4, 5 | Not used | |
| 6 | Rx - (receive) | Tx - (transmit) |
| 7, 8 | Not used | |

RJ-45 Connector pin assignment

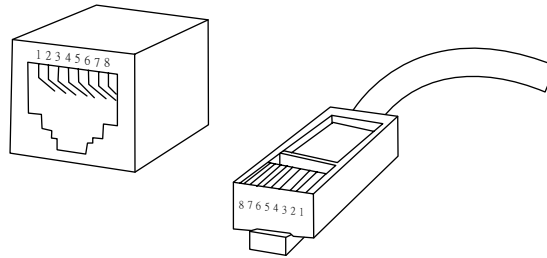

The standard RJ-45 receptacle/connector

There are 8 wires on a standard UTP/STP cable and each wire is color-coded. The following shows the pin allocation and color of straight cable and crossover cable connection:

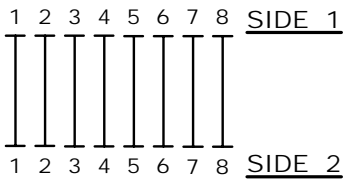
Straight CableSIDE 1

1 = White/Orange
 2 = Orange
 3 = White/Green
 4 = Blue
 5 = White/Blue
 6 = Green
 7 = White/Brown
 8 = Brown

SIDE 2

1 = White/Orange
 2 = Orange
 3 = White/Green
 4 = Blue
 5 = White/Blue
 6 = Green
 7 = White/Brown
 8 = Brown

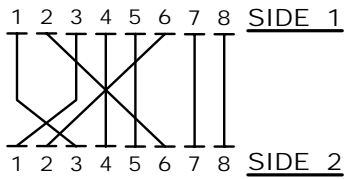
Cross Over CableSIDE 1

1 = White/Orange
 2 = Orange
 3 = White/Green
 4 = Blue
 5 = White/Blue
 6 = Green
 7 = White/Brown
 8 = Brown

SIDE 2

1 = White/Orange
 2 = Orange
 3 = White/Green
 4 = Blue
 5 = White/Blue
 6 = Green
 7 = White/Brown
 8 = Brown

Please make sure your connected cables are with same pin assignment and color as above picture before deploying the cables into your network.